

Echo246F

8th Gen Intel® Xeon®/Core™ i7/i5/i3 Fanless Embedded System
Workstation-grade, 10GigE LAN, Extended Temperature

USER Manual

Record of Revision

Version	Date	Page	Description	Remark
0.10	10/05/2018	All	Preliminary Release	
1.0	10/08/2018	All	Official Release	

Disclaimer

This manual is released by CappuccinoPC. for reference purpose only. All product offerings and specifications are subject to change without prior notice. It does not represent commitment of CappuccinoPC. CappuccinoPC shall not be liable for direct, indirect, special, incidental, or consequential damages arising out of the use of the product or documentation or any infringements upon the rights of third parties, which may result from such use.

Declaration of Conformity

FCC

This equipment has been tested and found to comply with the limits for a Class A digital device, pursuant to part 15 of the FCC Rules. These limits are designed to provide reasonable protection against harmful interference when the equipment is operated in a commercial environment. This equipment generates, uses, and can radiate radio frequency energy, and if it is not installed and used in accordance with the instruction manual, it may cause harmful interference to radio communications. Operation of this equipment in a residential area is likely to cause harmful interference in which case the user will be required to correct the interference at his own expense.

CE

The products described in this manual complies with all applicable European Union (CE) directives if it has a CE marking. For computer systems to remain CE compliant, only CE-compliant parts may be used. Maintaining CE compliance also requires proper cable and cabling techniques.

Copyright and Trademarks

This document contains proprietary information protected by copyright. No part of this publication may be reproduced in any form or by any means, electric, photocopying, recording or otherwise, without prior written authorization by CappuccinoPC. The rights of all the brand names, product names, and trademarks belong to their respective owners.

Order Information

Part Number	Description
Echo246F-G9R	9 GigE LAN with 4 PoE ⁺ , 2 Front-access SSD Tray, 2 M.2, 6 USB 3.1, 4 COM, 2 SIM, 16 Isolated DIO
Echo246F-G9	9 GigE LAN with 4 PoE ⁺ , 2 M.2, 6 USB 3.1, 4 COM, 2 SIM, 16 Isolated DIO
Echo246F-PoER	6 GigE LAN with 4 PoE ⁺ , 2 Front-access SSD Tray, 2 M.2, 6 USB 3.1, 4 COM, 2 SIM, 16 Isolated DIO
Echo246F-PoE	6 GigE LAN with 4 PoE ⁺ , 2 M.2, 6 USB 3.1, 4 COM, 2 SIM, 16 Isolated DIO
Echo246F-FOR	6 GigE LAN with 2 SFP, 2 Front-access SSD Tray, 2 M.2, 6 USB 3.1, 4 COM, 2 SIM, 16 GPIO
Echo246F-FO	6 GigE LAN with 2 SFP, 2 M.2, 6 USB 3.1, 4 COM, 2 SIM, 16 GPIO
Echo246F-G4R	4 GigE LAN, 2 Front-access SSD Tray, 2 M.2, 6 USB 3.1, 4 COM, 2 SIM, 16 GPIO
Echo246F-G4	4 GigE LAN, 2 M.2, 6 USB 3.1, 4 COM, 2 SIM, 16 GPIO
Echo246FR	2 GigE LAN, 2 Front-access SSD Tray, 2 M.2, 6 USB 3.1, 4 COM, 2 SIM, 16 GPIO
Echo246F	2 GigE LAN, 2 M.2, 6 USB 3.1, 4 COM, 2 SIM, 16 GPIO
Echo 246F-10GJR	6 GigE LAN with 4 PoE ⁺ , 2 10GigE LAN, 2 Front-access SSD Tray, 2 M.2, 6 USB 3.1, 4 COM, 2 SIM, 16 Isolated DIO
Echo 246F-10GJ	6 GigE LAN with 4 PoE ⁺ , 2 10GigE LAN, 2 M.2, 6 USB 3.1, 4 COM, 2 SIM, 16 Isolated DIO
Echo 246F-10GSR	6 GigE LAN with 4 PoE ⁺ , 2 10G SFP+, 2 Front-access SSD Tray, 2 M.2, 6 USB 3.1, 4 COM, 2 SIM, 16 Isolated DIO
Echo 246F-10GS	6 GigE LAN with 4 PoE ⁺ , 2 10G SFP+, 2 M.2, 6 USB 3.1, 4 COM, 2 SIM, 16 Isolated DIO

Order Accessories

Part Number	Description
E-2176G	Intel® Xeon® E-2176G Processor (12M Cache, up to 4.70GHz)
E-2124G	Intel® Xeon® E-2124G Processor (8M Cache, up to 4.50GHz)
i7-8700	8th Gen Intel® Core™ i7-8700 Processor (12M Cache, up to 4.60GHz)
i7-8700T	8th Gen Intel® Core™ i7-8700TE Processor (12M Cache, up to 4.00GHz)
i5-8500	8th Gen Intel® Core™ i5-8500 Processor (9M Cache, up to 4.10GHz)
i5-8500T	8th Gen Intel® Core™ i5-8500TE Processor (9M Cache, up to 3.50GHz)
i3-8100	8th Gen Intel® Core™ i3-8100 Processor (6M Cache, 3.60GHz)
i3-8100T	8th Gen Intel® Core™ i3-8100TE Processor (6M Cache, 3.10GHz)
DDR4 32G	Certified DDR4 32GB 2666MHz RAM
DDR4 16G	Certified DDR4 16GB 2666/2400/2133MHz RAM
DDR4 8G	Certified DDR4 8GB 2666/2400/2133MHz RAM
DDR4 4G	Certified DDR4 4GB 2666/2400/2133MHz RAM
P280W-WT	280W, 24V, 85V AC to 264V AC Power Adaptor with 3-pin Terminal Block, Wide Temperature -30°C to +70°C
P160W-WT	160W, 24V, 85V AC to 264V AC Power Adaptor with 3-pin Terminal Block, Wide Temperature -30°C to +70°C
VESA Mount	VESA Mounting Kit
DIN-RAIL Kit	DIN Rail and VESA Mounting Kit
Rack Mount	2U Rackmount Kit
T20P-100	Terminal Block 20-pin to Terminal Block 20-pin Cable, 100cm
T20P-500	Terminal Block 20-pin to Terminal Block 20-pin Cable, 500cm
TMB-T20P	Terminal Board with One 20-pin Terminal Block Connector and DIN-Rail Mounting
4G Module	Mini PCIe 4G/GPS Module with Antenna
WiFi & Bluetooth	WiFi & Bluetooth Module with Antenna

Table of Contents

CHAPTER 1	GENERAL INTRODUCTION	1
1.1	Overview	1
1.2	Features	2
1.3	Product Specification	3
1.3.1	Specifications of Echo 246F-G9R	3
1.3.2	Specifications of Echo 246F-G9	5
1.3.3	Specifications of Echo 246F-PoER	7
1.3.4	Specifications of Echo 246F-PoE	9
1.3.5	Specifications of Echo 246F-FOR	11
1.3.6	Specifications of Echo 246F-FO	13
1.3.7	Specifications of Echo 246F-G4R	15
1.3.8	Specifications of Echo 246F-G4	17
1.3.9	Specifications of Echo 246F-2R	19
1.3.10	Specifications of Echo 246F2G	21
1.3.11	Specifications of Echo 246F-10GJR	23
1.3.12	Specifications of Echo 246F-10GJ	25
1.3.13	Specifications of Echo 246F-10GSR	27
1.3.14	Specifications of Echo 246F-10GS	29
1.4	Supported CPU List	31
1.5	Mechanical Dimension	31
1.5.1	Dimensions of Echo 246F-G9R	31
1.5.2	Dimensions of Echo 246F-G9	31
1.5.3	Dimensions of Echo 246F-PoER	32
1.5.4	Dimensions of Echo 246F-PoE	32
1.5.5	Dimensions of Echo 246F-FOR	32
1.5.6	Dimensions of Echo 246F-6FO	33
1.5.7	Dimensions of Echo 246F-G4R	33
1.5.8	Dimensions of Echo 246F-G4	33
1.5.9	Dimensions of Echo 246FR	34
1.5.10	Dimensions of Echo 246F	34
1.5.11	Dimensions of Echo 246F-10GJR	34
1.5.12	Dimensions of Echo 246F-10GJ	35
1.5.13	Dimensions of Echo 246F-10GSR	35
1.5.14	Dimensions of Echo 246F-10GS	35

CHAPTER 2	GETTING TO KNOW YOUR Echo 246F	36
2.1	Packing List	36
2.2	Front Panel I/O Functions	38
2.3	Rear Panel I/O & Functions	47
2.4	Main Board Expansion Connectors	53
2.5	Main Board Jumper Settings	65
2.6	Ignition Control	68
CHAPTER 3	SYSTEM SETUP	71
3.1	How to Open Your Echo 246F	71
3.2	Installing CPU	77
3.3	Installing DDR4 SO-DIMM Modules	88
3.4	Installing Mini PCIe Card	90
3.5	Installing Antenna Cable	92
3.6	Installing CFast Card	94
3.7	Installing SIM Card	95
3.8	Installing SSD/HDD	96
3.9	Installing M.2	100
3.10	Mounting Your Echo 246F	101
CHAPTER 4	BIOS SETUP	103
4.1	Entering BIOS Setup	103
4.2	Main	104
4.3	Advanced	104
4.4	Chipset	116
4.5	Security	121
4.6	Boot	123
4.7	Save & Exit	124

APPENDIX A : Isolated DIO Guide	125
APPENDIX B : Software Functions	132
APPENDIX C : Power Consumption	137
APPENDIX D : RAID Functions	141
APPENDIX E : Supported Memory & Storage List	147

1

GENERAL INTRODUCTION

1.1 Overview

Echo 246F Series is a workstation-grade compact integrated Fanless Embedded System. LGA1151 Socket supports workstation-grade 6-core 8th Generation Intel® Xeon®/Core™ i7/i5/i3 processor (Coffee Lake-S) running with workstation-grade Intel® C246 chipset, dual channel DDR4 2666MHz up to 64GB ECC memory, advanced Intel® UHD Graphics P630/630 supporting DirectX 12, OpenGL 4.5 and OpenCL 2.0 API, onboard DVI-I, DVI-D and DisplayPort display interface for Ultra HD 4K resolution. Echo 246F delivers new generation CPU & chipset performance, power efficiency, and graphics performance; multiple 10GigE (10Gbps), PCIe 3.0 (8GT/s), SATA III (6Gbps), USB 3.1 (5Gbps), PoE (1Gbps) LAN and wireless connections make seamless real-time high-speed data conveying possible. Echo 246F Series Fanless Embedded System delivers outstanding system performance and power productivity for demanding workloads in real-time mission critical embedded computing applications.

Fanless -40°C to 75°C operating temperature, onboard DVI-I, DVI-D and DisplayPort display interfaces support triple independent displays, 9 GigE LAN ports with 4 IEEE 802.3at (25.5W/48V) PoE⁺ without additional power connections, max 6 external USB 3.1 connections, 2 Front-access 2.5" SSD/HDD trays, up to 5 Mini PCIe expansions for multiple WiFi/4G/3G/LTE/GPRS/UMTS wireless data transfer, 1 Front-access CFast socket, 2 SATA III support software RAID function, 4 COM RS-232/422/485, 2 M.2 expansions, 16 Isolated DIO, 6V to 36V wide range power input with 80V surge protection, configurable ignition power control, smart remote management features, remote power switch, EN50155 and EN50121-3-2 compliant, optional full function SUMIT A, B expansion supports multiple 10GigE RJ45/SPF+ Fiber connections, the Echo 246F Series Fanless Embedded System serves new-generation compact integrated functions for any AI-oriented embedded applications.

With outstanding system performance, leading integrated features & functions, smart manageability, flexible mobile availability, secure power protection and rugged reliability, Echo 246F Series Fanless Embedded System is your great solution for Machine Vision, Intelligent Automation, Smart Manufacturing, Intelligent Surveillance, Vehicle Computing, Robotic Control, and any Artificial Intelligence oriented real-time Industrial IoT or Industry 4.0 embedded applications.

1.2 Features

- LGA 1151 Socket supports 6 cores 8th Generation Intel® Xeon®/Core™ i7/i5/i3 Processor (Coffee Lake) with workstation-grade Intel® C246 Chipset
- Fanless, -40°C to 75°C Operating Temperature
- 2 DDR4 2666MHz Memory, up to 64GB
- Up to 9 GigE LAN with 4 IEEE 802.3at PoE⁺, iAMT 12.0 supported
- 6 Independent GigE LAN with 2 SFP, iAMT 12.0 supported (Echo 246F-FOR/Echo 246F-FO)
- DVI-I, DVI-D and DisplayPort display interface, up to 4K display
- 6 USB 3.1, 4 COM RS-232/422/485, 16 Isolated DIO
- 2 External SIM Card sockets support WiFi/4G/3G/LTE/GPRS/UMTS
- Storage : Up to 2 Front-access 2.5" HDD/SSD Tray, 1 Front-access CFast Socket, 1 M.2 Socket
- Expansion : SUMIT A, B, M.2, up to 5 Mini PCIe
- 6V to 36V DC Power Input with 80V Surge Protection
- Configurable Ignition Power Control
- Optional supports multiple 10GigE RJ45/10GigE SFP+ Configuration (Echo 246F-10GJR/Echo 246F-10GJ/Echo 246F-10GSR/Echo 246F-10GS)

1.3 Product Specification

1.3.1 Specifications of Echo 246F-G9R

System	
Processor	6 cores Intel® Xeon®/Core™ i7/i5/i3 Processor (Coffee Lake-S)
Chipset	Intel® C246 Chipset
BIOS	AMI
SIO	IT8786E
Memory	<ul style="list-style-type: none"> • DDR4 2666MHz (ECC/Non-ECC) • Up to 64GB • 2 260-pin SO-DIMM Socket
I/O Interface	
Serial	4 COM RS-232/422/485 (ESD 8KV)
USB	<ul style="list-style-type: none"> • 6 USB 3.1 (External) • 1 USB 2.0 (Internal)
Isolated DIO	16 Isolated DIO : 8 DI, 8 DO
LED	Power, HDD, Wireless, PoE
SIM Card	2 SIM Card Socket (External)
Expansion	
Mini PCIe	2 Full-size Mini PCIe Socket for PCIe/USB/External SIM Card/mSATA
M.2	1 M.2 Key E Socket
Graphics	
Graphics Processor	Intel® UHD Graphics P630/630
Interface	<ul style="list-style-type: none"> • DVI-I : Up to 1920 x 1200 @ 60Hz • DVI-D : Up to 1920 x 1080 @ 60Hz • DisplayPort : Up to 4096 x 2304 @ 60Hz
Storage	
SATA	2 SATA III (6Gbps) support S/W RAID 0, 1
mSATA	2 SATA III (Mini PCIe Type, 6Gbps)
Storage Device	<ul style="list-style-type: none"> • 1 CFAST Socket, Push-in/Push-out Ejector • 2 Front-access 2.5" SSD/HDD Tray • 1 M.2 Key M Socket
Audio	
Audio Codec	Realtek ALC892, 5.1 Channel HD Audio
Audio Interface	1 Mic-in, 1 Line-out
Ethernet	
LAN 1	Intel® I219LM GigE LAN supports iAMT 12.0
LAN 2	Intel® I210 GigE LAN
LAN 7	Intel® 82574L GigE LAN
LAN 8	Intel® 82574L GigE LAN
LAN 9	Intel® 82574L GigE LAN

PoE	
LAN 3	GigE IEEE 802.3at (25.5W/48V) PoE ⁺ by Intel [®] I210
LAN 4	GigE IEEE 802.3at (25.5W/48V) PoE ⁺ by Intel [®] I210
LAN 5	GigE IEEE 802.3at (25.5W/48V) PoE ⁺ by Intel [®] I210
LAN 6	GigE IEEE 802.3at (25.5W/48V) PoE ⁺ by Intel [®] I210
Power	
Input Voltage	6V to 36V, DC-in
Power Interface	<ul style="list-style-type: none"> 3-pin Terminal Block : V+, V-, Frame Ground Mini-DIN 4-pin
Ignition Control	16 Mode (Internal)
Remote Switch	3-pin Terminal Block : On, Off, IGN
Surge Protection	Up to 80V/1ms Transient Power
Others	
TPM	Optional Infineon SLB9665 supports TPM 2.0, LPC interface
Watchdog Timer	Reset : 1 to 255 sec./min. per step
Smart Management	Wake on LAN, PXE supported
HW Monitor	Monitoring temperature, voltages. Auto throttling control when CPU overheats.
Software Support	
OS	Windows 10, Linux
Mechanical	
Dimensions (WxDxH)	260mm x 175mm x 79mm (10.2" x 6.9" x 3.1")
Weight	3.8 kg (8.38 lb)
Mounting	<ul style="list-style-type: none"> Wallmount by mounting bracket DIN Rail Mount (Optional) 2U Rackmount (Optional)
Environment	
Operating Temperature	35W TDP CPU : -40°C to 75°C (-40°F to 167°F) 65W TDP CPU : -40°C to 55°C (-40°F to 131°F) 80W TDP CPU : -40°C to 45°C (-40°F to 113°F)
Storage Temperature	-40°C to 85°C (-40°F to 185°F)
Humidity	5% to 95% humidity, non-condensing
Relative Humidity	95% at 75°C
Shock	<ul style="list-style-type: none"> IEC 60068-2-27 SSD : 50G @ wallmount, Half-sine, 11ms
Vibration	<ul style="list-style-type: none"> IEC 60068-2-64 SSD : 5Grms, 5Hz to 500Hz, 3 Axis
EMC	CE, FCC, EN50155, EN50121-3-2

1.3.2 Specifications of Echo 246F-G9

System	
Processor	6 cores Intel® Xeon®/Core™ i7/i5/i3 Processor (Coffee Lake-S)
Chipset	Intel® C246 Chipset
BIOS	AMI
SIO	IT8786E
Memory	<ul style="list-style-type: none"> • DDR4 2666MHz (ECC/Non-ECC) • Up to 64GB • 2 260-pin SO-DIMM Socket
I/O Interface	
Serial	4 COM RS-232/422/485 (ESD 8KV)
USB	<ul style="list-style-type: none"> • 6 USB 3.1 (External) • 1 USB 2.0 (Internal)
Isolated DIO	16 Isolated DIO : 8 DI, 8 DO
LED	Power, HDD, Wireless, PoE
SIM Card	2 SIM Card Socket (External)
Expansion	
Mini PCIe	2 Full-size Mini PCIe Socket for PCIe/USB/External SIM Card/mSATA
M.2	1 M.2 Key E Socket
Graphics	
Graphics Processor	Intel® UHD Graphics P630/630
Interface	<ul style="list-style-type: none"> • DVI-I : Up to 1920 x 1200 @ 60Hz • DVI-D : Up to 1920 x 1080 @ 60Hz • DisplayPort : Up to 4096 x 2304 @ 60Hz
Storage	
SATA	2 SATA III (6Gbps) support S/W RAID 0, 1
mSATA	2 SATA III (Mini PCIe Type, 6Gbps)
Storage Device	<ul style="list-style-type: none"> • 1 CFast Socket, Push-in/Push-out Ejector • 2 2.5" SSD/HDD Bracket (Internal) • 1 M.2 Key M Socket
Audio	
Audio Codec	Realtek ALC892, 5.1 Channel HD Audio
Audio Interface	1 Mic-in, 1 Line-out
Ethernet	
LAN 1	Intel® I219LM GigE LAN supports iAMT 12.0
LAN 2	Intel® I210 GigE LAN
LAN 7	Intel® 82574L GigE LAN
LAN 8	Intel® 82574L GigE LAN
LAN 9	Intel® 82574L GigE LAN

PoE	
LAN 3	GigE IEEE 802.3at (25.5W/48V) PoE ⁺ by Intel [®] I210
LAN 4	GigE IEEE 802.3at (25.5W/48V) PoE ⁺ by Intel [®] I210
LAN 5	GigE IEEE 802.3at (25.5W/48V) PoE ⁺ by Intel [®] I210
LAN 6	GigE IEEE 802.3at (25.5W/48V) PoE ⁺ by Intel [®] I210
Power	
Input Voltage	6V to 36V, DC-in
Power Interface	<ul style="list-style-type: none"> • 3-pin Terminal Block : V+, V-, Frame Ground • Mini-DIN 4-pin
Ignition Control	16 Mode (Internal)
Remote Switch	3-pin Terminal Block : On, Off, IGN
Surge Protection	Up to 80V/1ms Transient Power
Others	
TPM	Optional Infineon SLB9665 supports TPM 2.0, LPC interface
Watchdog Timer	Reset : 1 to 255 sec./min. per step
Smart Management	Wake on LAN, PXE supported
HW Monitor	Monitoring temperature, voltages. Auto throttling control when CPU overheats.
Software Support	
OS	Windows 10, Linux
Mechanical	
Dimensions (WxDxH)	260mm x 175mm x 79mm (10.2" x 6.9" x 3.1")
Weight	3.8 kg (8.38 lb)
Mounting	<ul style="list-style-type: none"> • Wallmount by mounting bracket • DIN Rail Mount (Optional) • 2U Rackmount (Optional)
Environment	
Operating Temperature	35W TDP CPU : -40°C to 75°C (-40°F to 167°F) 65W TDP CPU : -40°C to 55°C (-40°F to 131°F) 80W TDP CPU : -40°C to 45°C (-40°F to 113°F)
Storage Temperature	-40°C to 85°C (-40°F to 185°F)
Humidity	5% to 95% humidity, non-condensing
Relative Humidity	95% at 75°C
Shock	<ul style="list-style-type: none"> • IEC 60068-2-27 • SSD : 50G @ wallmount, Half-sine, 11ms
Vibration	<ul style="list-style-type: none"> • IEC 60068-2-64 • SSD : 5Grms, 5Hz to 500Hz, 3 Axis
EMC	CE, FCC, EN50155, EN50121-3-2

1.3.3 Specifications of Echo 246F-PoER

System	
Processor	6 cores Intel® Xeon®/Core™ i7/i5/i3 Processor (Coffee Lake-S)
Chipset	Intel® C246 Chipset
BIOS	AMI
SIO	IT8786E
Memory	<ul style="list-style-type: none"> • DDR4 2666MHz (ECC/Non-ECC) • Up to 64GB • 2 260-pin SO-DIMM Socket
I/O Interface	
Serial	4 COM RS-232/422/485 (ESD 8KV)
USB	<ul style="list-style-type: none"> • 6 USB 3.1 (External) • 1 USB 2.0 (Internal)
Isolated DIO	16 Isolated DIO : 8 DI, 8 DO
LED	Power, HDD, Wireless, PoE
SIM Card	2 SIM Card Socket (External)
Expansion	
Mini PCIe	2 Full-size Mini PCIe Socket for PCIe/USB/External SIM Card/mSATA
M.2	1 M.2 Key E Socket
Graphics	
Graphics Processor	Intel® UHD Graphics P630/630
Interface	<ul style="list-style-type: none"> • DVI-I : Up to 1920 x 1200 @ 60Hz • DVI-D : Up to 1920 x 1080 @ 60Hz • DisplayPort : Up to 4096 x 2304 @ 60Hz
Storage	
SATA	2 SATA III (6Gbps) support S/W RAID 0, 1
mSATA	2 SATA III (Mini PCIe Type, 6Gbps)
Storage Device	<ul style="list-style-type: none"> • 1 CFAST Socket, Push-in/Push-out Ejector • 2 Front-access 2.5" SSD/HDD Tray • 1 M.2 Key M Socket
Audio	
Audio Codec	Realtek ALC892, 5.1 Channel HD Audio
Audio Interface	1 Mic-in, 1 Line-out
Ethernet	
LAN 1	Intel® I219LM GigE LAN supports iAMT 12.0
LAN 2	Intel® I210 GigE LAN

PoE	
LAN 3	GigE IEEE 802.3at (25.5W/48V) PoE ⁺ by Intel [®] I210
LAN 4	GigE IEEE 802.3at (25.5W/48V) PoE ⁺ by Intel [®] I210
LAN 5	GigE IEEE 802.3at (25.5W/48V) PoE ⁺ by Intel [®] I210
LAN 6	GigE IEEE 802.3at (25.5W/48V) PoE ⁺ by Intel [®] I210
Power	
Input Voltage	6V to 36V, DC-in
Power Interface	<ul style="list-style-type: none"> • 3-pin Terminal Block : V+, V-, Frame Ground • Mini-DIN 4-pin
Ignition Control	16 Mode (Internal)
Remote Switch	3-pin Terminal Block : On, Off, IGN
Surge Protection	Up to 80V/1ms Transient Power
Others	
TPM	Optional Infineon SLB9665 supports TPM 2.0, LPC interface
Watchdog Timer	Reset : 1 to 255 sec./min. per step
Smart Management	Wake on LAN, PXE supported
HW Monitor	Monitoring temperature, voltages. Auto throttling control when CPU overheats.
Software Support	
OS	Windows 10, Linux
Mechanical	
Dimensions (WxDxH)	260mm x 175mm x 79mm (10.2" x 6.9" x 3.1")
Weight	3.8 kg (8.38 lb)
Mounting	<ul style="list-style-type: none"> • Wallmount by mounting bracket • DIN Rail Mount (Optional) • 2U Rackmount (Optional)
Environment	
Operating Temperature	35W TDP CPU : -40°C to 75°C (-40°F to 167°F) 65W TDP CPU : -40°C to 55°C (-40°F to 131°F) 80W TDP CPU : -40°C to 45°C (-40°F to 113°F)
Storage Temperature	-40°C to 85°C (-40°F to 185°F)
Humidity	5% to 95% humidity, non-condensing
Relative Humidity	95% at 75°C
Shock	<ul style="list-style-type: none"> • IEC 60068-2-27 • SSD : 50G @ wallmount, Half-sine, 11ms
Vibration	<ul style="list-style-type: none"> • IEC 60068-2-64 • SSD : 5Grms, 5Hz to 500Hz, 3 Axis
EMC	CE, FCC, EN50155, EN50121-3-2

1.3.4 Specifications of Echo 246F-PoE

System	
Processor	6 cores Intel® Xeon®/Core™ i7/i5/i3 Processor (Coffee Lake-S)
Chipset	Intel® C246 Chipset
BIOS	AMI
SIO	IT8786E
Memory	<ul style="list-style-type: none"> • DDR4 2666MHz (ECC/Non-ECC) • Up to 64GB • 2 260-pin SO-DIMM Socket
I/O Interface	
Serial	4 COM RS-232/422/485 (ESD 8KV)
USB	<ul style="list-style-type: none"> • 6 USB 3.1 (External) • 1 USB 2.0 (Internal)
Isolated DIO	16 Isolated DIO : 8 DI, 8 DO
LED	Power, HDD, Wireless, PoE
SIM Card	2 SIM Card Socket (External)
Expansion	
Mini PCIe	2 Full-size Mini PCIe Socket for PCIe/USB/External SIM Card/mSATA
M.2	1 M.2 Key E Socket
Graphics	
Graphics Processor	Intel® UHD Graphics P630/630
Interface	<ul style="list-style-type: none"> • DVI-I : Up to 1920 x 1200 @ 60Hz • DVI-D : Up to 1920 x 1080 @ 60Hz • DisplayPort : Up to 4096 x 2304 @ 60Hz
Storage	
SATA	2 SATA III (6Gbps) support S/W RAID 0, 1
mSATA	2 SATA III (Mini PCIe Type, 6Gbps)
Storage Device	<ul style="list-style-type: none"> • 1 CFAST Socket, Push-in/Push-out Ejector • 2 2.5" SSD/HDD Bracket (Internal) • 1 M.2 Key M Socket
Audio	
Audio Codec	Realtek ALC892, 5.1 Channel HD Audio
Audio Interface	1 Mic-in, 1 Line-out
Ethernet	
LAN 1	Intel® I219LM GigE LAN supports iAMT 12.0
LAN 2	Intel® I210 GigE LAN

PoE	
LAN 3	GigE IEEE 802.3at (25.5W/48V) PoE ⁺ by Intel [®] I210
LAN 4	GigE IEEE 802.3at (25.5W/48V) PoE ⁺ by Intel [®] I210
LAN 5	GigE IEEE 802.3at (25.5W/48V) PoE ⁺ by Intel [®] I210
LAN 6	GigE IEEE 802.3at (25.5W/48V) PoE ⁺ by Intel [®] I210
Power	
Input Voltage	6V to 36V, DC-in
Power Interface	<ul style="list-style-type: none"> 3-pin Terminal Block : V+, V-, Frame Ground Mini-DIN 4-pin
Ignition Control	16 Mode (Internal)
Remote Switch	3-pin Terminal Block : On, Off, IGN
Surge Protection	Up to 80V/1ms Transient Power
Others	
TPM	Optional Infineon SLB9665 supports TPM 2.0, LPC interface
Watchdog Timer	Reset : 1 to 255 sec./min. per step
Smart Management	Wake on LAN, PXE supported
HW Monitor	Monitoring temperature, voltages. Auto throttling control when CPU overheats.
Software Support	
OS	Windows 10, Linux
Mechanical	
Dimensions (WxDxH)	260mm x 175mm x 79mm (10.2" x 6.9" x 3.1")
Weight	3.8 kg (8.38 lb)
Mounting	<ul style="list-style-type: none"> Wallmount by mounting bracket DIN Rail Mount (Optional) 2U Rackmount (Optional)
Environment	
Operating Temperature	35W TDP CPU : -40°C to 75°C (-40°F to 167°F) 65W TDP CPU : -40°C to 55°C (-40°F to 131°F) 80W TDP CPU : -40°C to 45°C (-40°F to 113°F)
Storage Temperature	-40°C to 85°C (-40°F to 185°F)
Humidity	5% to 95% humidity, non-condensing
Relative Humidity	95% at 75°C
Shock	<ul style="list-style-type: none"> IEC 60068-2-27 SSD : 50G @ wallmount, Half-sine, 11ms
Vibration	<ul style="list-style-type: none"> IEC 60068-2-64 SSD : 5Grms, 5Hz to 500Hz, 3 Axis
EMC	CE, FCC, EN50155, EN50121-3-2

1.3.5 Specifications of Echo 246F-FOR

System	
Processor	6 cores Intel® Xeon®/Core™ i7/i5/i3 Processor (Coffee Lake-S)
Chipset	Intel® C246 Chipset
BIOS	AMI
SIO	IT8786E
Memory	<ul style="list-style-type: none"> • DDR4 2666MHz (ECC/Non-ECC) • Up to 64GB • 2 260-pin SO-DIMM Socket
I/O Interface	
Serial	4 COM RS-232/422/485 (ESD 8KV)
USB	<ul style="list-style-type: none"> • 6 USB 3.1 (External) • 1 USB 2.0 (Internal)
GPIO	16 GPIO
LED	Power, HDD, Wireless
SIM Card	2 SIM Card Socket (External)
Expansion	
Mini PCIe	2 Full-size Mini PCIe Socket for PCIe/USB/External SIM Card/mSATA
M.2	1 M.2 Key E Socket
Graphics	
Graphics Processor	Intel® UHD Graphics P630/630
Interface	<ul style="list-style-type: none"> • DVI-I : Up to 1920 x 1200 @ 60Hz • DVI-D : Up to 1920 x 1080 @ 60Hz • DisplayPort : Up to 4096 x 2304 @ 60Hz
Storage	
SATA	2 SATA III (6Gbps) support S/W RAID 0, 1
mSATA	2 SATA III (Mini PCIe Type, 6Gbps)
Storage Device	<ul style="list-style-type: none"> • 1 CFAST Socket, Push-in/Push-out Ejector • 2 Front-access 2.5" SSD/HDD Tray • 1 M.2 Key M Socket
Audio	
Audio Codec	Realtek ALC892, 5.1 Channel HD Audio
Audio Interface	1 Mic-in, 1 Line-out
Ethernet	
LAN 1	Intel® I219LM GigE LAN supports iAMT 12.0
LAN 2	Intel® I210 GigE LAN
LAN 3	Intel® I210 GigE LAN
LAN 4	Intel® I210 GigE LAN

SFP	
LAN 5	1000BASE SFP by Intel® I350
LAN 6	1000BASE SFP by Intel® I350
Power	
Input Voltage	6V to 36V, DC-in
Power Interface	<ul style="list-style-type: none"> 3-pin Terminal Block : V+, V-, Frame Ground Mini-DIN 4-pin
Ignition Control	16 Mode (Internal)
Remote Switch	3-pin Terminal Block : On, Off, IGN
Surge Protection	Up to 80V/1ms Transient Power
Others	
TPM	Optional Infineon SLB9665 supports TPM 2.0, LPC interface
Watchdog Timer	Reset : 1 to 255 sec./min. per step
Smart Management	Wake on LAN, PXE supported
HW Monitor	Monitoring temperature, voltages. Auto throttling control when CPU overheats.
Software Support	
OS	Windows 10, Linux
Mechanical	
Dimensions (WxDxH)	260mm x 175mm x 79mm (10.2" x 6.9" x 3.1")
Weight	3.8 kg (8.38 lb)
Mounting	<ul style="list-style-type: none"> Wallmount by mounting bracket DIN Rail Mount (Optional) 2U Rackmount (Optional)
Environment	
Operating Temperature	35W TDP CPU : -40°C to 75°C (-40°F to 167°F) 65W TDP CPU : -40°C to 55°C (-40°F to 131°F) 80W TDP CPU : -40°C to 45°C (-40°F to 113°F)
Storage Temperature	-40°C to 85°C (-40°F to 185°F)
Humidity	5% to 95% humidity, non-condensing
Relative Humidity	95% at 75°C
Shock	<ul style="list-style-type: none"> IEC 60068-2-27 SSD : 50G @ wallmount, Half-sine, 11ms
Vibration	<ul style="list-style-type: none"> IEC 60068-2-64 SSD : 5Grms, 5Hz to 500Hz, 3 Axis
EMC	CE, FCC, EN50155, EN50121-3-2

1.3.6 Specifications of Echo 246F-FO

System	
Processor	6 cores Intel® Xeon®/Core™ i7/i5/i3 Processor (Coffee Lake-S)
Chipset	Intel® C246 Chipset
BIOS	AMI
SIO	IT8786E
Memory	<ul style="list-style-type: none"> • DDR4 2666MHz (ECC/Non-ECC) • Up to 64GB • 2 260-pin SO-DIMM Socket
I/O Interface	
Serial	4 COM RS-232/422/485 (ESD 8KV)
USB	<ul style="list-style-type: none"> • 6 USB 3.1 (External) • 1 USB 2.0 (Internal)
GPIO	16 GPIO
LED	Power, HDD, Wireless
SIM Card	2 SIM Card Socket (External)
Expansion	
Mini PCIe	2 Full-size Mini PCIe Socket for PCIe/USB/External SIM Card/mSATA
M.2	1 M.2 Key E Socket
Graphics	
Graphics Processor	Intel® UHD Graphics P630/630
Interface	<ul style="list-style-type: none"> • DVI-I : Up to 1920 x 1200 @ 60Hz • DVI-D : Up to 1920 x 1080 @ 60Hz • DisplayPort : Up to 4096 x 2304 @ 60Hz
Storage	
SATA	2 SATA III (6Gbps) support S/W RAID 0, 1
mSATA	2 SATA III (Mini PCIe Type, 6Gbps)
Storage Device	<ul style="list-style-type: none"> • 1 CFAST Socket, Push-in/Push-out Ejector • 2 2.5" SSD/HDD Bracket (Internal) • 1 M.2 Key M Socket
Audio	
Audio Codec	Realtek ALC892, 5.1 Channel HD Audio
Audio Interface	1 Mic-in, 1 Line-out
Ethernet	
LAN 1	Intel® I219LM GigE LAN supports iAMT 12.0
LAN 2	Intel® I210 GigE LAN
LAN 3	Intel® I210 GigE LAN
LAN 4	Intel® I210 GigE LAN

SFP	
LAN 5	1000BASE SFP by Intel® I350
LAN 6	1000BASE SFP by Intel® I350
Power	
Input Voltage	6V to 36V, DC-in
Power Interface	<ul style="list-style-type: none"> 3-pin Terminal Block : V+, V-, Frame Ground Mini-DIN 4-pin
Ignition Control	16 Mode (Internal)
Remote Switch	3-pin Terminal Block : On, Off, IGN
Surge Protection	Up to 80V/1ms Transient Power
Others	
TPM	Optional Infineon SLB9665 supports TPM 2.0, LPC interface
Watchdog Timer	Reset : 1 to 255 sec./min. per step
Smart Management	Wake on LAN, PXE supported
HW Monitor	Monitoring temperature, voltages. Auto throttling control when CPU overheats.
Software Support	
OS	Windows 10, Linux
Mechanical	
Dimensions (WxDxH)	260mm x 175mm x 79mm (10.2" x 6.9" x 3.1")
Weight	3.8 kg (8.38 lb)
Mounting	<ul style="list-style-type: none"> Wallmount by mounting bracket DIN Rail Mount (Optional) 2U Rackmount (Optional)
Environment	
Operating Temperature	35W TDP CPU : -40°C to 75°C (-40°F to 167°F) 65W TDP CPU : -40°C to 55°C (-40°F to 131°F) 80W TDP CPU : -40°C to 45°C (-40°F to 113°F)
Storage Temperature	-40°C to 85°C (-40°F to 185°F)
Humidity	5% to 95% humidity, non-condensing
Relative Humidity	95% at 75°C
Shock	<ul style="list-style-type: none"> IEC 60068-2-27 SSD : 50G @ wallmount, Half-sine, 11ms
Vibration	<ul style="list-style-type: none"> IEC 60068-2-64 SSD : 5Grms, 5Hz to 500Hz, 3 Axis
EMC	CE, FCC, EN50155, EN50121-3-2

1.3.7 Specifications of Echo 246F-G4R

System	
Processor	6 cores Intel® Xeon®/Core™ i7/i5/i3 Processor (Coffee Lake-S)
Chipset	Intel® C246 Chipset
BIOS	AMI
SIO	IT8786E
Memory	<ul style="list-style-type: none"> • DDR4 2666MHz (ECC/Non-ECC) • Up to 64GB • 2 260-pin SO-DIMM Socket
I/O Interface	
Serial	4 COM RS-232/422/485 (ESD 8KV)
USB	<ul style="list-style-type: none"> • 6 USB 3.1 (External) • 1 USB 2.0 (Internal)
GPIO	16 GPIO
LED	Power, HDD, Wireless
SIM Card	2 SIM Card Socket (External)
Expansion	
Mini PCIe	2 Full-size Mini PCIe Socket for PCIe/USB/External SIM Card/mSATA
M.2	1 M.2 Key E Socket
SUMIT A, B	2 SUMIT Slot (Optional)
Graphics	
Graphics Processor	Intel® UHD Graphics P630/630
Interface	<ul style="list-style-type: none"> • DVI-I : Up to 1920 x 1200 @ 60Hz • DVI-D : Up to 1920 x 1080 @ 60Hz • DisplayPort : Up to 4096 x 2304 @ 60Hz
Storage	
SATA	2 SATA III (6Gbps) support S/W RAID 0, 1
mSATA	2 SATA III (Mini PCIe Type, 6Gbps)
Storage Device	<ul style="list-style-type: none"> • 1 CFast Socket, Push-in/Push-out Ejector • 2 Front-access 2.5" SSD/HDD Tray • 1 M.2 Key M Socket
Audio	
Audio Codec	Realtek ALC892, 5.1 Channel HD Audio
Audio Interface	1 Mic-in, 1 Line-out
Ethernet	
LAN 1	Intel® I219LM GigE LAN supports iAMT 12.0
LAN 2	Intel® I210 GigE LAN
LAN 3	Intel® I210 GigE LAN
LAN 4	Intel® I210 GigE LAN

Power	
Input Voltage	6V to 36V, DC-in
Power Interface	<ul style="list-style-type: none"> 3-pin Terminal Block : V+, V-, Frame Ground Mini-DIN 4-pin
Ignition Control	16 Mode (Internal)
Remote Switch	3-pin Terminal Block : On, Off, IGN
Surge Protection	Up to 80V/1ms Transient Power
Others	
TPM	Optional Infineon SLB9665 supports TPM 2.0, LPC interface
Watchdog Timer	Reset : 1 to 255 sec./min. per step
Smart Management	Wake on LAN, PXE supported
HW Monitor	Monitoring temperature, voltages. Auto throttling control when CPU overheats.
Software Support	
OS	Windows 10, Linux
Mechanical	
Dimensions (WxDxH)	260mm x 175mm x 79mm (10.2" x 6.9" x 3.1")
Weight	3.8 kg (8.38 lb)
Mounting	<ul style="list-style-type: none"> Wallmount by mounting bracket DIN Rail Mount (Optional) 2U Rackmount (Optional)
Environment	
Operating Temperature	35W TDP CPU : -40°C to 75°C (-40°F to 167°F) 65W TDP CPU : -40°C to 55°C (-40°F to 131°F) 80W TDP CPU : -40°C to 45°C (-40°F to 113°F)
Storage Temperature	-40°C to 85°C (-40°F to 185°F)
Humidity	5% to 95% humidity, non-condensing
Relative Humidity	95% at 75°C
Shock	<ul style="list-style-type: none"> IEC 60068-2-27 SSD : 50G @ wallmount, Half-sine, 11ms
Vibration	<ul style="list-style-type: none"> IEC 60068-2-64 SSD : 5Grms, 5Hz to 500Hz, 3 Axis
EMC	CE, FCC, EN50155, EN50121-3-2

1.3.8 Specifications of Echo 246F-G4

System	
Processor	6 cores Intel® Xeon®/Core™ i7/i5/i3 Processor (Coffee Lake-S)
Chipset	Intel® C246 Chipset
BIOS	AMI
SIO	IT8786E
Memory	<ul style="list-style-type: none"> • DDR4 2666MHz (ECC/Non-ECC) • Up to 64GB • 2 260-pin SO-DIMM Socket
I/O Interface	
Serial	4 COM RS-232/422/485 (ESD 8KV)
USB	<ul style="list-style-type: none"> • 6 USB 3.1 (External) • 1 USB 2.0 (Internal)
GPIO	16 GPIO
LED	Power, HDD, Wireless
SIM Card	2 SIM Card Socket (External)
Expansion	
Mini PCIe	2 Full-size Mini PCIe Socket for PCIe/USB/External SIM Card/mSATA
M.2	1 M.2 Key E Socket
SUMIT A, B	2 SUMIT Slot (Optional)
Graphics	
Graphics Processor	Intel® UHD Graphics P630/630
Interface	<ul style="list-style-type: none"> • DVI-I : Up to 1920 x 1200 @ 60Hz • DVI-D : Up to 1920 x 1080 @ 60Hz • DisplayPort : Up to 4096 x 2304 @ 60Hz
Storage	
SATA	2 SATA III (6Gbps) support S/W RAID 0, 1
mSATA	2 SATA III (Mini PCIe Type, 6Gbps)
Storage Device	<ul style="list-style-type: none"> • 1 CFast Socket, Push-in/Push-out Ejector • 2 2.5" SSD/HDD Bracket (Internal) • 1 M.2 Key M Socket
Audio	
Audio Codec	Realtek ALC892, 5.1 Channel HD Audio
Audio Interface	1 Mic-in, 1 Line-out
Ethernet	
LAN 1	Intel® I219LM GigE LAN supports iAMT 12.0
LAN 2	Intel® I210 GigE LAN
LAN 3	Intel® I210 GigE LAN
LAN 4	Intel® I210 GigE LAN

Power	
Input Voltage	6V to 36V, DC-in
Power Interface	<ul style="list-style-type: none"> • 3-pin Terminal Block : V+, V-, Frame Ground • Mini-DIN 4-pin
Ignition Control	16 Mode (Internal)
Remote Switch	3-pin Terminal Block : On, Off, IGN
Surge Protection	Up to 80V/1ms Transient Power
Others	
TPM	Optional Infineon SLB9665 supports TPM 2.0, LPC interface
Watchdog Timer	Reset : 1 to 255 sec./min. per step
Smart Management	Wake on LAN, PXE supported
HW Monitor	Monitoring temperature, voltages. Auto throttling control when CPU overheats.
Software Support	
OS	Windows 10, Linux
Mechanical	
Dimensions (WxDxH)	260mm x 175mm x 79mm (10.2" x 6.9" x 3.1")
Weight	3.8 kg (8.38 lb)
Mounting	<ul style="list-style-type: none"> • Wallmount by mounting bracket • DIN Rail Mount (Optional) • 2U Rackmount (Optional)
Environment	
Operating Temperature	35W TDP CPU : -40°C to 75°C (-40°F to 167°F) 65W TDP CPU : -40°C to 55°C (-40°F to 131°F) 80W TDP CPU : -40°C to 45°C (-40°F to 113°F)
Storage Temperature	-40°C to 85°C (-40°F to 185°F)
Humidity	5% to 95% humidity, non-condensing
Relative Humidity	95% at 75°C
Shock	<ul style="list-style-type: none"> • IEC 60068-2-27 • SSD : 50G @ wallmount, Half-sine, 11ms
Vibration	<ul style="list-style-type: none"> • IEC 60068-2-64 • SSD : 5Grms, 5Hz to 500Hz, 3 Axis
EMC	CE, FCC, EN50155, EN50121-3-2

1.3.9 Specifications of Echo 246FR

System	
Processor	6 cores Intel® Xeon®/Core™ i7/i5/i3 Processor (Coffee Lake-S)
Chipset	Intel® C246 Chipset
BIOS	AMI
SIO	IT8786E
Memory	<ul style="list-style-type: none"> • DDR4 2666MHz (ECC/Non-ECC) • Up to 64GB • 2 260-pin SO-DIMM Socket
I/O Interface	
Serial	4 COM RS-232/422/485 (ESD 8KV)
USB	<ul style="list-style-type: none"> • 6 USB 3.1 (External) • 1 USB 2.0 (Internal)
GPIO	16 GPIO
LED	Power, HDD, Wireless
SIM Card	2 SIM Card Socket (External)
Expansion	
Mini PCIe	2 Full-size Mini PCIe Socket for PCIe/USB/External SIM Card/mSATA
M.2	1 M.2 Key E Socket
SUMIT A, B	2 SUMIT Slot (Optional)
Graphics	
Graphics Processor	Intel® UHD Graphics P630/630
Interface	<ul style="list-style-type: none"> • DVI-I : Up to 1920 x 1200 @ 60Hz • DVI-D : Up to 1920 x 1080 @ 60Hz • DisplayPort : Up to 4096 x 2304 @ 60Hz
Storage	
SATA	2 SATA III (6Gbps) support S/W RAID 0, 1
mSATA	2 SATA III (Mini PCIe Type, 6Gbps)
Storage Device	<ul style="list-style-type: none"> • 1 CFast Socket, Push-in/Push-out Ejector • 2 Front-access 2.5" SSD/HDD Tray • 1 M.2 Key M Socket
Audio	
Audio Codec	Realtek ALC892, 5.1 Channel HD Audio
Audio Interface	1 Mic-in, 1 Line-out
Ethernet	
LAN 1	Intel® I219LM GigE LAN supports iAMT 12.0
LAN 2	Intel® I210 GigE LAN

Power	
Input Voltage	6V to 36V, DC-in
Power Interface	<ul style="list-style-type: none"> • 3-pin Terminal Block : V+, V-, Frame Ground • Mini-DIN 4-pin
Ignition Control	16 Mode (Internal)
Remote Switch	3-pin Terminal Block : On, Off, IGN
Surge Protection	Up to 80V/1ms Transient Power
Others	
TPM	Optional Infineon SLB9665 supports TPM 2.0, LPC interface
Watchdog Timer	Reset : 1 to 255 sec./min. per step
Smart Management	Wake on LAN, PXE supported
HW Monitor	Monitoring temperature, voltages. Auto throttling control when CPU overheats.
Software Support	
OS	Windows 10, Linux
Mechanical	
Dimensions (WxDxH)	260mm x 175mm x 79mm (10.2" x 6.9" x 3.1")
Weight	3.8 kg (8.38 lb)
Mounting	<ul style="list-style-type: none"> • Wallmount by mounting bracket • DIN Rail Mount (Optional) • 2U Rackmount (Optional)
Environment	
Operating Temperature	35W TDP CPU : -40°C to 75°C (-40°F to 167°F) 65W TDP CPU : -40°C to 55°C (-40°F to 131°F) 80W TDP CPU : -40°C to 45°C (-40°F to 113°F)
Storage Temperature	-40°C to 85°C (-40°F to 185°F)
Humidity	5% to 95% humidity, non-condensing
Relative Humidity	95% at 75°C
Shock	<ul style="list-style-type: none"> • IEC 60068-2-27 • SSD : 50G @ wallmount, Half-sine, 11ms
Vibration	<ul style="list-style-type: none"> • IEC 60068-2-64 • SSD : 5Grms, 5Hz to 500Hz, 3 Axis
EMC	CE, FCC, EN50155, EN50121-3-2

1.3.10 Specifications of Echo 246F

System	
Processor	6 cores Intel® Xeon®/Core™ i7/i5/i3 Processor (Coffee Lake-S)
Chipset	Intel® C246 Chipset
BIOS	AMI
SIO	IT8786E
Memory	<ul style="list-style-type: none"> • DDR4 2666MHz (ECC/Non-ECC) • Up to 64GB • 2 260-pin SO-DIMM Socket
I/O Interface	
Serial	4 COM RS-232/422/485 (ESD 8KV)
USB	<ul style="list-style-type: none"> • 6 USB 3.1 (External) • 1 USB 2.0 (Internal)
GPIO	16 GPIO
LED	Power, HDD, Wireless
SIM Card	2 SIM Card Socket (External)
Expansion	
Mini PCIe	2 Full-size Mini PCIe Socket for PCIe/USB/External SIM Card/mSATA
M.2	1 M.2 Key E Socket
SUMIT A, B	2 SUMIT Slot (Optional)
Graphics	
Graphics Processor	Intel® UHD Graphics P630/630
Interface	<ul style="list-style-type: none"> • DVI-I : Up to 1920 x 1200 @ 60Hz • DVI-D : Up to 1920 x 1080 @ 60Hz • DisplayPort : Up to 4096 x 2304 @ 60Hz
Storage	
SATA	2 SATA III (6Gbps) support S/W RAID 0, 1
mSATA	2 SATA III (Mini PCIe Type, 6Gbps)
Storage Device	<ul style="list-style-type: none"> • 1 CFast Socket, Push-in/Push-out Ejector • 2 2.5" SSD/HDD Bracket (Internal) • 1 M.2 Key M Socket
Audio	
Audio Codec	Realtek ALC892, 5.1 Channel HD Audio
Audio Interface	1 Mic-in, 1 Line-out
Ethernet	
LAN 1	Intel® I219LM GigE LAN supports iAMT 12.0
LAN 2	Intel® I210 GigE LAN

Power	
Input Voltage	6V to 36V, DC-in
Power Interface	<ul style="list-style-type: none"> • 3-pin Terminal Block : V+, V-, Frame Ground • Mini-DIN 4-pin
Ignition Control	16 Mode (Internal)
Remote Switch	3-pin Terminal Block : On, Off, IGN
Surge Protection	Up to 80V/1ms Transient Power
Others	
TPM	Optional Infineon SLB9665 supports TPM 2.0, LPC interface
Watchdog Timer	Reset : 1 to 255 sec./min. per step
Smart Management	Wake on LAN, PXE supported
HW Monitor	Monitoring temperature, voltages. Auto throttling control when CPU overheats.
Software Support	
OS	Windows 10, Linux
Mechanical	
Dimensions (WxDxH)	260mm x 175mm x 79mm (10.2" x 6.9" x 3.1")
Weight	3.8 kg (8.38 lb)
Mounting	<ul style="list-style-type: none"> • Wallmount by mounting bracket • DIN Rail Mount (Optional) • 2U Rackmount (Optional)
Environment	
Operating Temperature	35W TDP CPU : -40°C to 75°C (-40°F to 167°F) 65W TDP CPU : -40°C to 55°C (-40°F to 131°F) 80W TDP CPU : -40°C to 45°C (-40°F to 113°F)
Storage Temperature	-40°C to 85°C (-40°F to 185°F)
Humidity	5% to 95% humidity, non-condensing
Relative Humidity	95% at 75°C
Shock	<ul style="list-style-type: none"> • IEC 60068-2-27 • SSD : 50G @ wallmount, Half-sine, 11ms
Vibration	<ul style="list-style-type: none"> • IEC 60068-2-64 • SSD : 5Grms, 5Hz to 500Hz, 3 Axis
EMC	CE, FCC, EN50155, EN50121-3-2

1.3.11 Specifications of Echo 246F-10GJR

System	
Processor	6 cores Intel® Xeon®/Core™ i7/i5/i3 Processor (Coffee Lake-S)
Chipset	Intel® C246 Chipset
BIOS	AMI
SIO	IT8786E
Memory	<ul style="list-style-type: none"> • DDR4 2666MHz (ECC/Non-ECC) • Up to 64GB • 2 260-pin SO-DIMM Socket
I/O Interface	
Serial	4 COM RS-232/422/485 (ESD 8KV)
USB	<ul style="list-style-type: none"> • 6 USB 3.1 (External) • 1 USB 2.0 (Internal)
Isolated DIO	16 Isolated DIO : 8 DI, 8 DO
LED	Power, HDD, Wireless, PoE
SIM Card	2 SIM Card Socket (External)
Expansion	
Mini PCIe	2 Full-size Mini PCIe Socket for PCIe/USB/External SIM Card/mSATA
M.2	1 M.2 Key E Socket
Graphics	
Graphics Processor	Intel® UHD Graphics P630/630
Interface	<ul style="list-style-type: none"> • DVI-I : Up to 1920 x 1200 @ 60Hz • DVI-D : Up to 1920 x 1080 @ 60Hz • DisplayPort : Up to 4096 x 2304 @ 60Hz
Storage	
SATA	2 SATA III (6Gbps) support S/W RAID 0, 1
mSATA	2 SATA III (Mini PCIe Type, 6Gbps)
Storage Device	<ul style="list-style-type: none"> • 1 CFAST Socket, Push-in/Push-out Ejector • 2 Front-access 2.5" SSD/HDD Tray • 1 M.2 Key M Socket
Audio	
Audio Codec	Realtek ALC892, 5.1 Channel HD Audio
Audio Interface	1 Mic-in, 1 Line-out
Ethernet	
LAN 1	Intel® I219LM GigE LAN supports iAMT 12.0
LAN 2	Intel® I210 GigE LAN

PoE	
LAN 3	GigE IEEE 802.3at (25.5W/48V) PoE ⁺ by Intel [®] I210
LAN 4	GigE IEEE 802.3at (25.5W/48V) PoE ⁺ by Intel [®] I210
LAN 5	GigE IEEE 802.3at (25.5W/48V) PoE ⁺ by Intel [®] I210
LAN 6	GigE IEEE 802.3at (25.5W/48V) PoE ⁺ by Intel [®] I210
10G Ethernet	
LAN 7	Intel [®] X550-AT2 10GigE LAN
LAN 8	Intel [®] X550-AT2 10GigE LAN
Power	
Input Voltage	6V to 36V, DC-in
Power Interface	<ul style="list-style-type: none"> • 3-pin Terminal Block : V+, V-, Frame Ground • Mini-DIN 4-pin
Ignition Control	16 Mode (Internal)
Remote Switch	3-pin Terminal Block : On, Off, IGN
Surge Protection	Up to 80V/1ms Transient Power
Others	
TPM	Optional Infineon SLB9665 supports TPM 2.0, LPC interface
Watchdog Timer	Reset : 1 to 255 sec./min. per step
Smart Management	Wake on LAN, PXE supported
HW Monitor	Monitoring temperature, voltages. Auto throttling control when CPU overheats.
Software Support	
OS	Windows 10, Linux
Mechanical	
Dimensions (WxDxH)	260mm x 175mm x 79mm (10.2" x 6.9" x 3.1")
Weight	3.8 kg (8.38 lb)
Mounting	<ul style="list-style-type: none"> • Wallmount by mounting bracket • DIN Rail Mount (Optional) • 2U Rackmount (Optional)
Environment	
Operating Temperature	-40°C to 55°C (-40°F to 131°F) 80W TDP CPU : -40°C to 45°C (-40°F to 113°F)
Storage Temperature	-40°C to 85°C (-40°F to 185°F)
Humidity	5% to 95% humidity, non-condensing
Relative Humidity	95% at 75°C
Shock	<ul style="list-style-type: none"> • IEC 60068-2-27 • SSD : 50G @ wallmount, Half-sine, 11ms
Vibration	<ul style="list-style-type: none"> • IEC 60068-2-64 • SSD : 5Grms, 5Hz to 500Hz, 3 Axis
EMC	CE, FCC, EN50155, EN50121-3-2

1.3.12 Specifications of Echo 246F-10GJ

System	
Processor	6 cores Intel® Xeon®/Core™ i7/i5/i3 Processor (Coffee Lake-S)
Chipset	Intel® C246 Chipset
BIOS	AMI
SIO	IT8786E
Memory	<ul style="list-style-type: none"> • DDR4 2666MHz (ECC/Non-ECC) • Up to 64GB • 2 260-pin SO-DIMM Socket
I/O Interface	
Serial	4 COM RS-232/422/485 (ESD 8KV)
USB	<ul style="list-style-type: none"> • 6 USB 3.1 (External) • 1 USB 2.0 (Internal)
Isolated DIO	16 Isolated DIO : 8 DI, 8 DO
LED	Power, HDD, Wireless, PoE
SIM Card	2 SIM Card Socket (External)
Expansion	
Mini PCIe	2 Full-size Mini PCIe Socket for PCIe/USB/External SIM Card/mSATA
M.2	1 M.2 Key E Socket
Graphics	
Graphics Processor	Intel® UHD Graphics P630/630
Interface	<ul style="list-style-type: none"> • DVI-I : Up to 1920 x 1200 @ 60Hz • DVI-D : Up to 1920 x 1080 @ 60Hz • DisplayPort : Up to 4096 x 2304 @ 60Hz
Storage	
SATA	2 SATA III (6Gbps) support S/W RAID 0, 1
mSATA	2 SATA III (Mini PCIe Type, 6Gbps)
Storage Device	<ul style="list-style-type: none"> • 1 CFAST Socket, Push-in/Push-out Ejector • 2 2.5" SSD/HDD Bracket (Internal) • 1 M.2 Key M Socket
Audio	
Audio Codec	Realtek ALC892, 5.1 Channel HD Audio
Audio Interface	1 Mic-in, 1 Line-out
Ethernet	
LAN 1	Intel® I219LM GigE LAN supports iAMT 12.0
LAN 2	Intel® I210 GigE LAN

PoE	
LAN 3	GigE IEEE 802.3at (25.5W/48V) PoE ⁺ by Intel [®] I210
LAN 4	GigE IEEE 802.3at (25.5W/48V) PoE ⁺ by Intel [®] I210
LAN 5	GigE IEEE 802.3at (25.5W/48V) PoE ⁺ by Intel [®] I210
LAN 6	GigE IEEE 802.3at (25.5W/48V) PoE ⁺ by Intel [®] I210
10G Ethernet	
LAN 7	Intel [®] X550-AT2 10GigE LAN
LAN 8	Intel [®] X550-AT2 10GigE LAN
Power	
Input Voltage	6V to 36V, DC-in
Power Interface	<ul style="list-style-type: none"> 3-pin Terminal Block : V+, V-, Frame Ground Mini-DIN 4-pin
Ignition Control	16 Mode (Internal)
Remote Switch	3-pin Terminal Block : On, Off, IGN
Surge Protection	Up to 80V/1ms Transient Power
Others	
TPM	Optional Infineon SLB9665 supports TPM 2.0, LPC interface
Watchdog Timer	Reset : 1 to 255 sec./min. per step
Smart Management	Wake on LAN, PXE supported
HW Monitor	Monitoring temperature, voltages. Auto throttling control when CPU overheats.
Software Support	
OS	Windows 10, Linux
Mechanical	
Dimensions (WxDxH)	260mm x 175mm x 79mm (10.2" x 6.9" x 3.1")
Weight	3.8 kg (8.38 lb)
Mounting	<ul style="list-style-type: none"> Wallmount by mounting bracket DIN Rail Mount (Optional) 2U Rackmount (Optional)
Environment	
Operating Temperature	-40°C to 55°C (-40°F to 131°F) 80W TDP CPU : -40°C to 45°C (-40°F to 113°F)
Storage Temperature	-40°C to 85°C (-40°F to 185°F)
Humidity	5% to 95% humidity, non-condensing
Relative Humidity	95% at 75°C
Shock	<ul style="list-style-type: none"> IEC 60068-2-27 SSD : 50G @ wallmount, Half-sine, 11ms
Vibration	<ul style="list-style-type: none"> IEC 60068-2-64 SSD : 5Grms, 5Hz to 500Hz, 3 Axis
EMC	CE, FCC, EN50155, EN50121-3-2

1.3.13 Specifications of Echo 246F-10GSR

System	
Processor	6 cores Intel® Xeon®/Core™ i7/i5/i3 Processor (Coffee Lake-S)
Chipset	Intel® C246 Chipset
BIOS	AMI
SIO	IT8786E
Memory	<ul style="list-style-type: none"> • DDR4 2666MHz (ECC/Non-ECC) • Up to 64GB • 2 260-pin SO-DIMM Socket
I/O Interface	
Serial	4 COM RS-232/422/485 (ESD 8KV)
USB	<ul style="list-style-type: none"> • 6 USB 3.1 (External) • 1 USB 2.0 (Internal)
Isolated DIO	16 Isolated DIO : 8 DI, 8 DO
LED	Power, HDD, Wireless, PoE
SIM Card	2 SIM Card Socket (External)
Expansion	
Mini PCIe	2 Full-size Mini PCIe Socket for PCIe/USB/External SIM Card/mSATA
M.2	1 M.2 Key E Socket
Graphics	
Graphics Processor	Intel® UHD Graphics P630/630
Interface	<ul style="list-style-type: none"> • DVI-I : Up to 1920 x 1200 @ 60Hz • DVI-D : Up to 1920 x 1080 @ 60Hz • DisplayPort : Up to 4096 x 2304 @ 60Hz
Storage	
SATA	2 SATA III (6Gbps) support S/W RAID 0, 1
mSATA	2 SATA III (Mini PCIe Type, 6Gbps)
Storage Device	<ul style="list-style-type: none"> • 1 CFAST Socket, Push-in/Push-out Ejector • 2 Front-access 2.5" SSD/HDD Tray • 1 M.2 Key M Socket
Audio	
Audio Codec	Realtek ALC892, 5.1 Channel HD Audio
Audio Interface	1 Mic-in, 1 Line-out
Ethernet	
LAN 1	Intel® I219LM GigE LAN supports iAMT 12.0
LAN 2	Intel® I210 GigE LAN

PoE	
LAN 3	GigE IEEE 802.3at (25.5W/48V) PoE ⁺ by Intel [®] I210
LAN 4	GigE IEEE 802.3at (25.5W/48V) PoE ⁺ by Intel [®] I210
LAN 5	GigE IEEE 802.3at (25.5W/48V) PoE ⁺ by Intel [®] I210
LAN 6	GigE IEEE 802.3at (25.5W/48V) PoE ⁺ by Intel [®] I210
10G Ethernet	
LAN 7	Intel [®] X710-BM2 10G SFP+ LAN supports IEEE 802.3 10GBASE-T SFP+
LAN 8	Intel [®] X710-BM2 10G SFP+ LAN supports IEEE 802.3 10GBASE-T SFP+
Power	
Input Voltage	6V to 36V, DC-in
Power Interface	<ul style="list-style-type: none"> • 3-pin Terminal Block : V+, V-, Frame Ground • Mini-DIN 4-pin
Ignition Control	16 Mode (Internal)
Remote Switch	3-pin Terminal Block : On, Off, IGN
Surge Protection	Up to 80V/1ms Transient Power
Others	
TPM	Optional Infineon SLB9665 supports TPM 2.0, LPC interface
Watchdog Timer	Reset : 1 to 255 sec./min. per step
Smart Management	Wake on LAN, PXE supported
HW Monitor	Monitoring temperature, voltages. Auto throttling control when CPU overheats.
Software Support	
OS	Windows 10, Linux
Mechanical	
Dimensions (WxDxH)	260mm x 175mm x 79mm (10.2" x 6.9" x 3.1")
Weight	3.8 kg (8.38 lb)
Mounting	<ul style="list-style-type: none"> • Wallmount by mounting bracket • DIN Rail Mount (Optional) • 2U Rackmount (Optional)
Environment	
Operating Temperature	-40°C to 55°C (-40°F to 131°F) 80W TDP CPU : -40°C to 45°C (-40°F to 113°F)
Storage Temperature	-40°C to 85°C (-40°F to 185°F)
Humidity	5% to 95% humidity, non-condensing
Relative Humidity	95% at 75°C
Shock	<ul style="list-style-type: none"> • IEC 60068-2-27 • SSD : 50G @ wallmount, Half-sine, 11ms
Vibration	<ul style="list-style-type: none"> • IEC 60068-2-64 • SSD : 5Grms, 5Hz to 500Hz, 3 Axis
EMC	CE, FCC, EN50155, EN50121-3-2

1.3.14 Specifications of Echo 246F-10GS

System	
Processor	6 cores Intel® Xeon®/Core™ i7/i5/i3 Processor (Coffee Lake-S)
Chipset	Intel® C246 Chipset
BIOS	AMI
SIO	IT8786E
Memory	<ul style="list-style-type: none"> • DDR4 2666MHz (ECC/Non-ECC) • Up to 64GB • 2 260-pin SO-DIMM Socket
I/O Interface	
Serial	4 COM RS-232/422/485 (ESD 8KV)
USB	<ul style="list-style-type: none"> • 6 USB 3.1 (External) • 1 USB 2.0 (Internal)
Isolated DIO	16 Isolated DIO : 8 DI, 8 DO
LED	Power, HDD, Wireless, PoE
SIM Card	2 SIM Card Socket (External)
Expansion	
Mini PCIe	2 Full-size Mini PCIe Socket for PCIe/USB/External SIM Card/mSATA
M.2	1 M.2 Key E Socket
Graphics	
Graphics Processor	Intel® UHD Graphics P630/630
Interface	<ul style="list-style-type: none"> • DVI-I : Up to 1920 x 1200 @ 60Hz • DVI-D : Up to 1920 x 1080 @ 60Hz • DisplayPort : Up to 4096 x 2304 @ 60Hz
Storage	
SATA	2 SATA III (6Gbps) support S/W RAID 0, 1
mSATA	2 SATA III (Mini PCIe Type, 6Gbps)
Storage Device	<ul style="list-style-type: none"> • 1 CFAST Socket, Push-in/Push-out Ejector • 2 2.5" SSD/HDD Bracket (Internal) • 1 M.2 Key M Socket
Audio	
Audio Codec	Realtek ALC892, 5.1 Channel HD Audio
Audio Interface	1 Mic-in, 1 Line-out
Ethernet	
LAN 1	Intel® I219LM GigE LAN supports iAMT 12.0
LAN 2	Intel® I210 GigE LAN

PoE	
LAN 3	GigE IEEE 802.3at (25.5W/48V) PoE ⁺ by Intel [®] I210
LAN 4	GigE IEEE 802.3at (25.5W/48V) PoE ⁺ by Intel [®] I210
LAN 5	GigE IEEE 802.3at (25.5W/48V) PoE ⁺ by Intel [®] I210
LAN 6	GigE IEEE 802.3at (25.5W/48V) PoE ⁺ by Intel [®] I210
10G Ethernet	
LAN 7	Intel [®] X710-BM2 10G SFP+ LAN supports IEEE 802.3 10GBASE-T SFP+
LAN 8	Intel [®] X710-BM2 10G SFP+ LAN supports IEEE 802.3 10GBASE-T SFP+
Power	
Input Voltage	6V to 36V, DC-in
Power Interface	<ul style="list-style-type: none"> • 3-pin Terminal Block : V+, V-, Frame Ground • Mini-DIN 4-pin
Ignition Control	16 Mode (Internal)
Remote Switch	3-pin Terminal Block : On, Off, IGN
Surge Protection	Up to 80V/1ms Transient Power
Others	
TPM	Optional Infineon SLB9665 supports TPM 2.0, LPC interface
Watchdog Timer	Reset : 1 to 255 sec./min. per step
Smart Management	Wake on LAN, PXE supported
HW Monitor	Monitoring temperature, voltages. Auto throttling control when CPU overheats.
Software Support	
OS	Windows 10, Linux
Mechanical	
Dimensions (WxDxH)	260mm x 175mm x 79mm (10.2" x 6.9" x 3.1")
Weight	3.8 kg (8.38 lb)
Mounting	<ul style="list-style-type: none"> • Wallmount by mounting bracket • DIN Rail Mount (Optional) • 2U Rackmount (Optional)
Environment	
Operating Temperature	-40°C to 55°C (-40°F to 131°F) 80W TDP CPU : -40°C to 45°C (-40°F to 113°F)
Storage Temperature	-40°C to 85°C (-40°F to 185°F)
Humidity	5% to 95% humidity, non-condensing
Relative Humidity	95% at 75°C
Shock	<ul style="list-style-type: none"> • IEC 60068-2-27 • SSD : 50G @ wallmount, Half-sine, 11ms
Vibration	<ul style="list-style-type: none"> • IEC 60068-2-64 • SSD : 5Grms, 5Hz to 500Hz, 3 Axis
EMC	CE, FCC, EN50155, EN50121-3-2

1.4 Supported CPU List

Processor No.	TDP	Cache	Max. Frequency	ECC Memory
Intel® Xeon® E-2176G	80W	12M	Up to 4.7GHz	Y
Intel® Xeon® E-2124G	71W	8M	Up to 4.5GHz	Y
Intel® Core™ i7-8700	65W	12M	Up to 4.6GHz	N
Intel® Core™ i7-8700T	35W	12M	Up to 4.0GHz	N
Intel® Core™ i5-8500	65W	9M	Up to 4.1GHz	N
Intel® Core™ i5-8500T	35W	9M	Up to 3.5GHz	N
Intel® Core™ i3-8100	65W	6M	Up to 3.6GHz	Y
Intel® Core™ i3-8100T	35W	6M	Up to 3.1GHz	Y

1.5 Mechanical Dimension

1.5.1 Dimensions of Echo246F-G9R

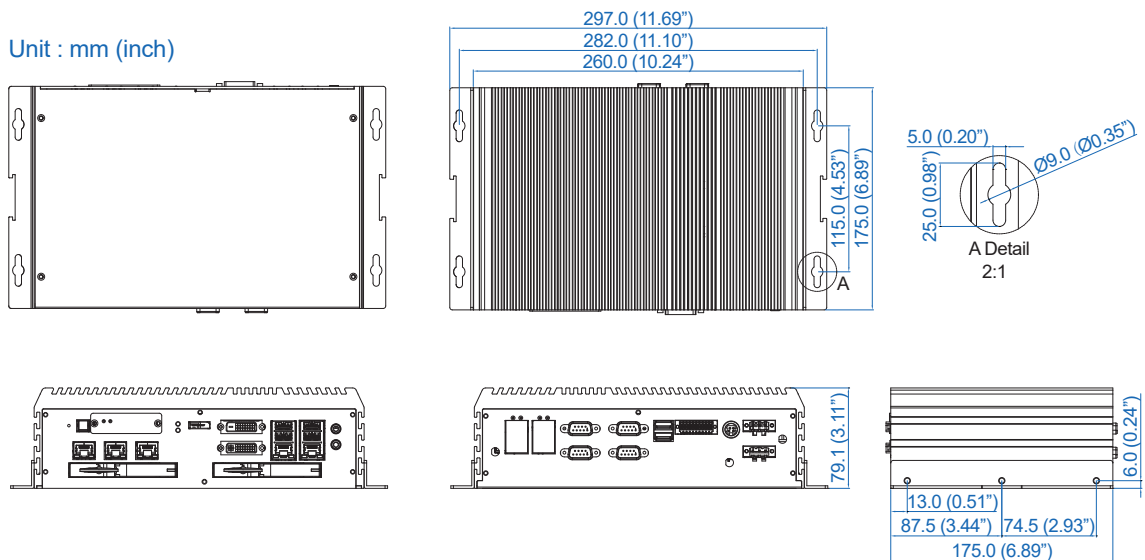

1.5.2 Dimensions of Echo246F-G9

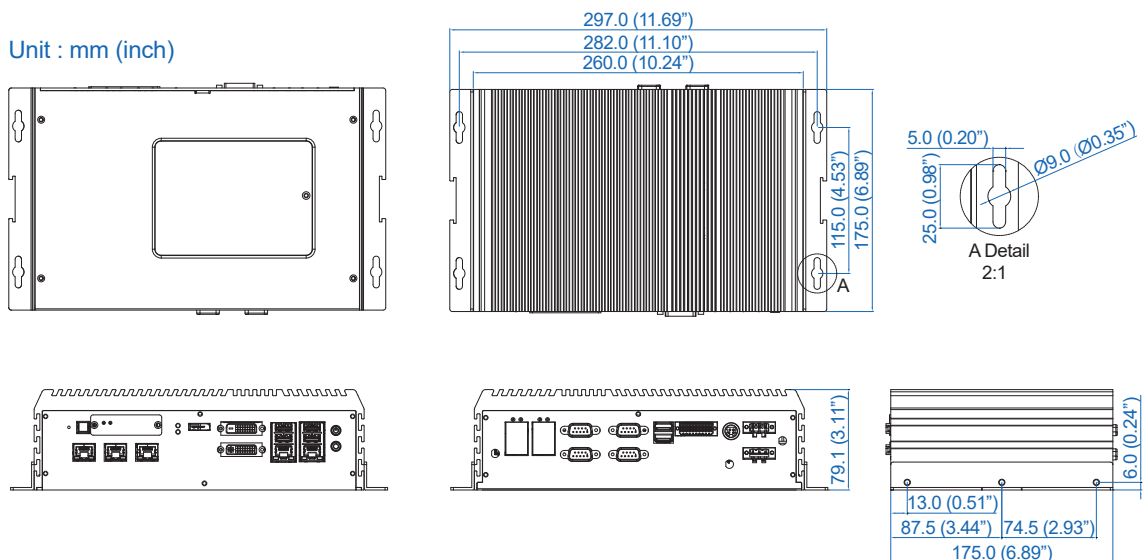

1.5.3 Dimensions of Echo246F-PoER

Unit : mm (inch)

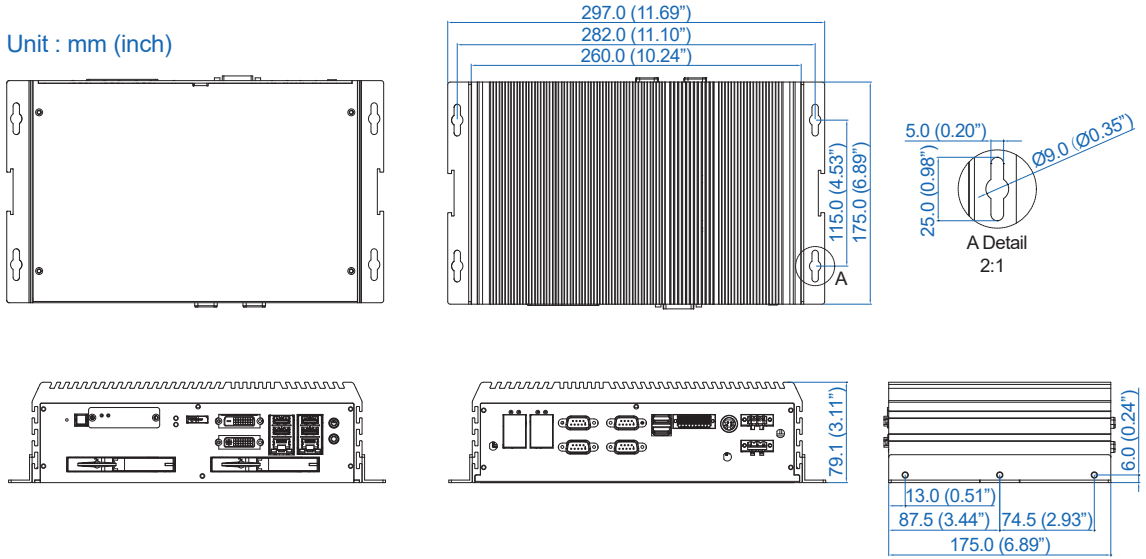

1.5.4 Dimensions of Echo246F-PoE

Unit : mm (inch)

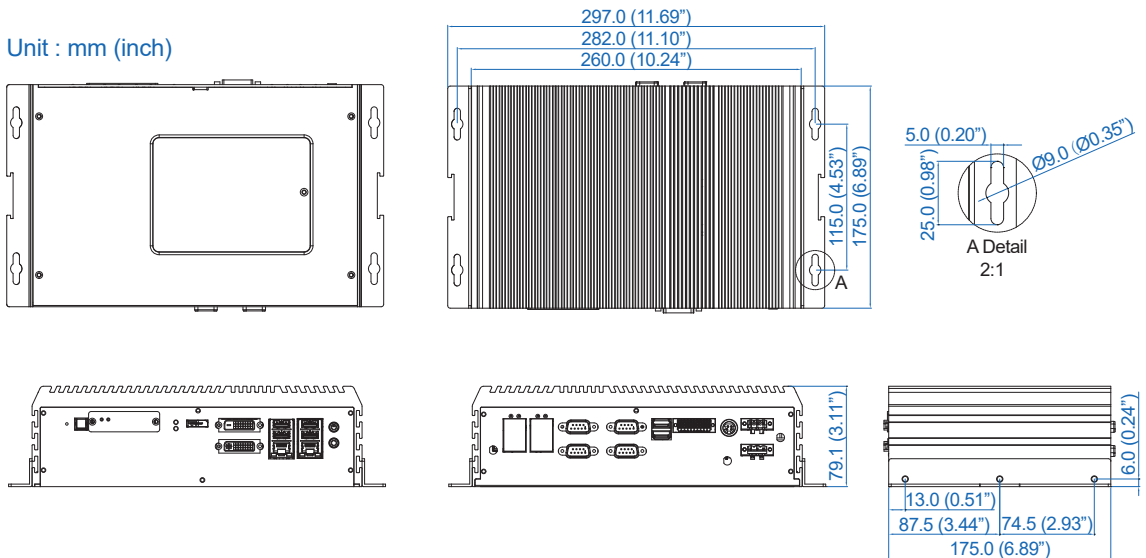

1.5.5 Dimensions of Echo246F-FOR

Unit : mm (inch)

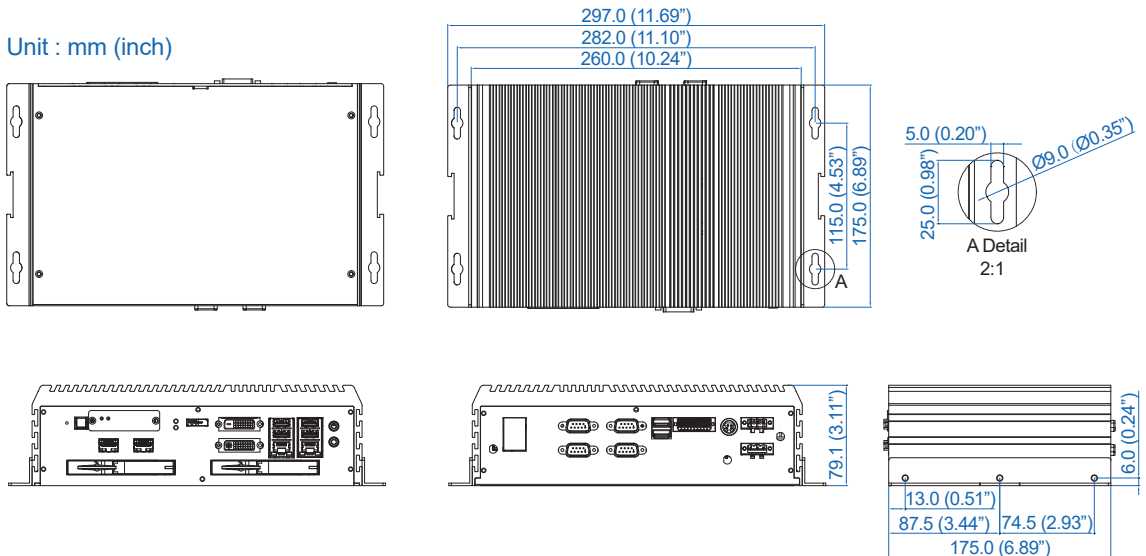

1.5.6 Dimensions of Echo246F-FO

Unit : mm (inch)

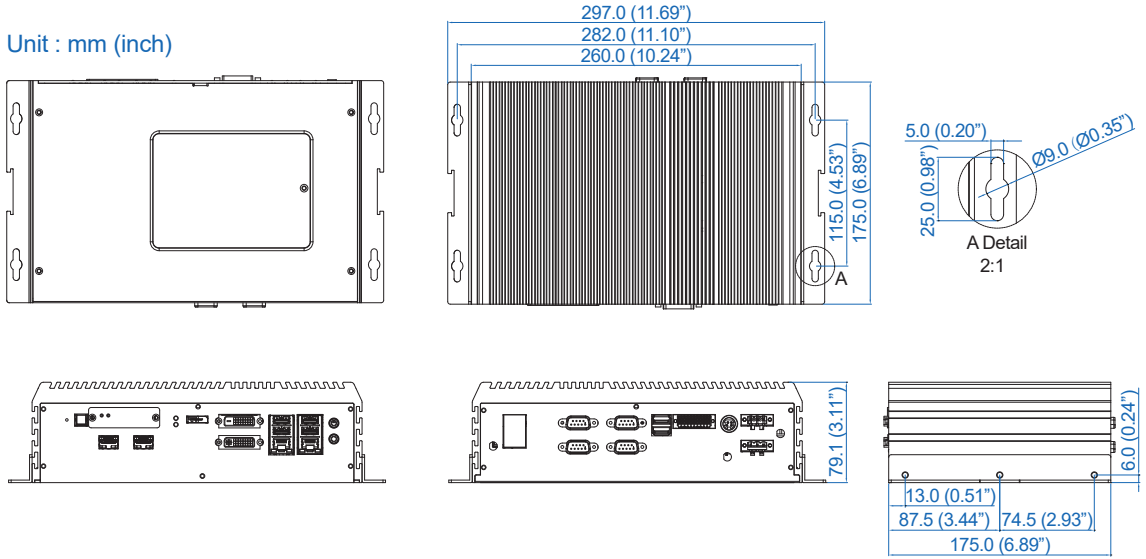

1.5.7 Dimensions of Echo246F-G4R

Unit : mm (inch)

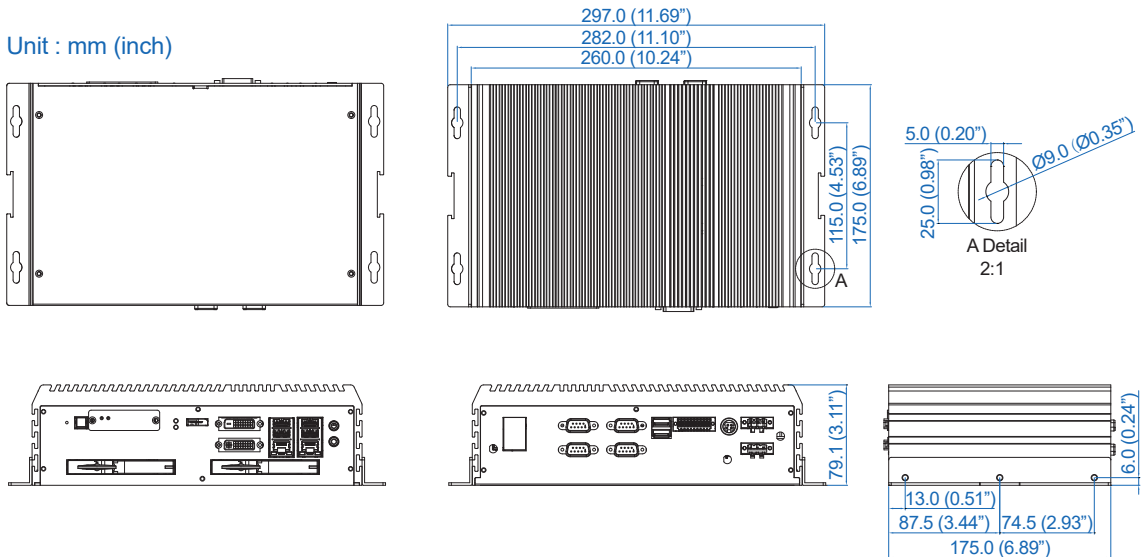

1.5.8 Dimensions of Echo246F-G4

Unit : mm (inch)

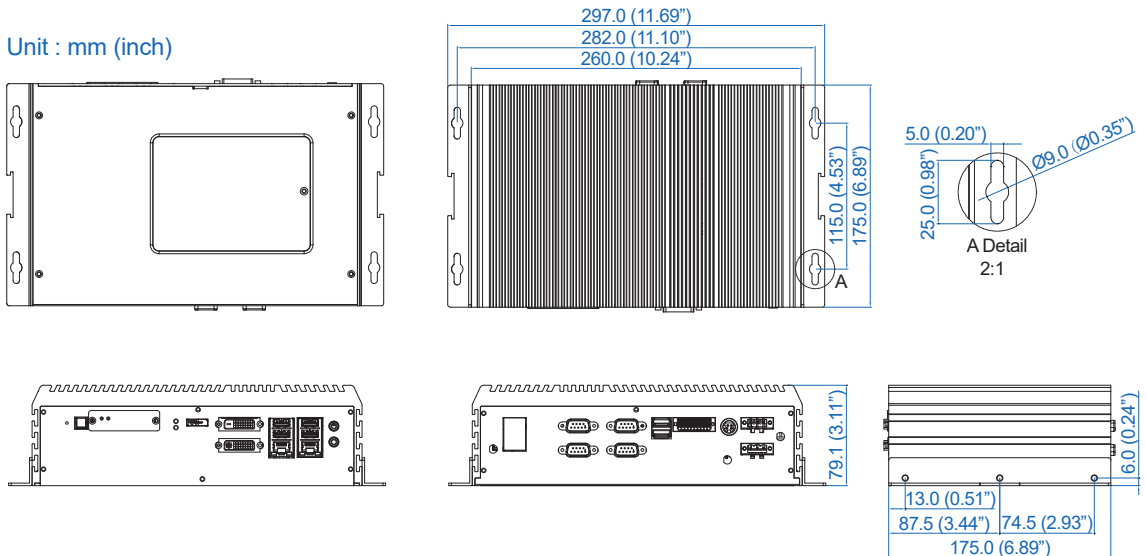

1.5.9 Dimensions of Echo246FR

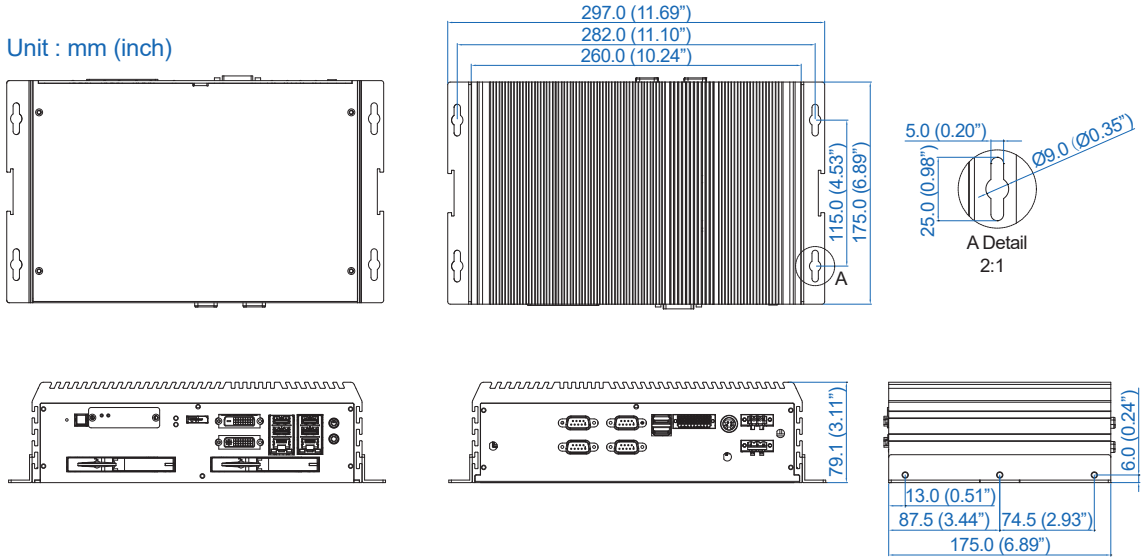

1.5.10 Dimensions of Echo246F

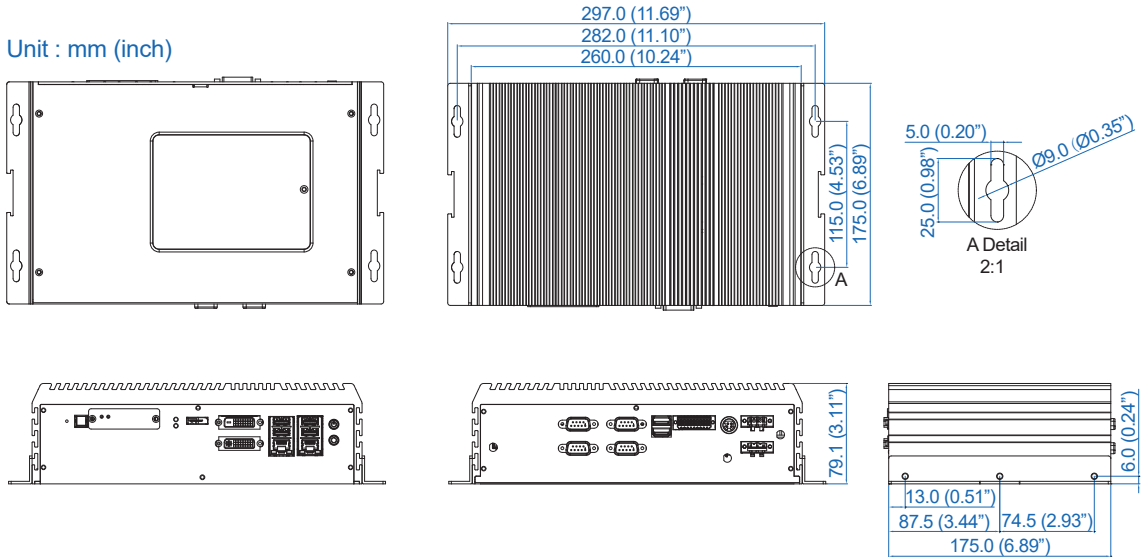

1.5.11 Dimensions of Echo 246F-10GJR

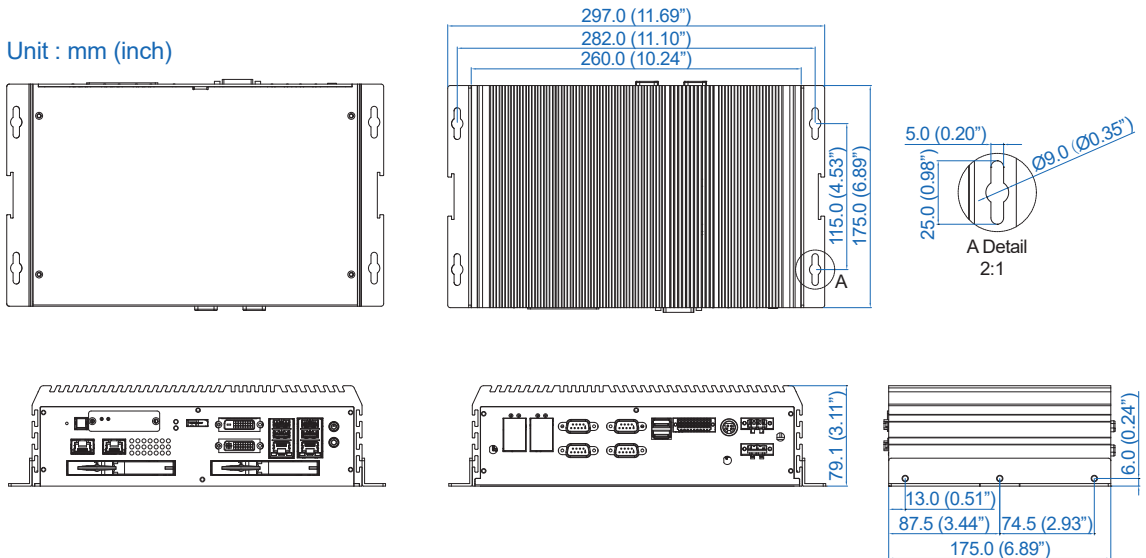

1.5.12 Dimensions of Echo 246F-10GJ

Unit : mm (inch)

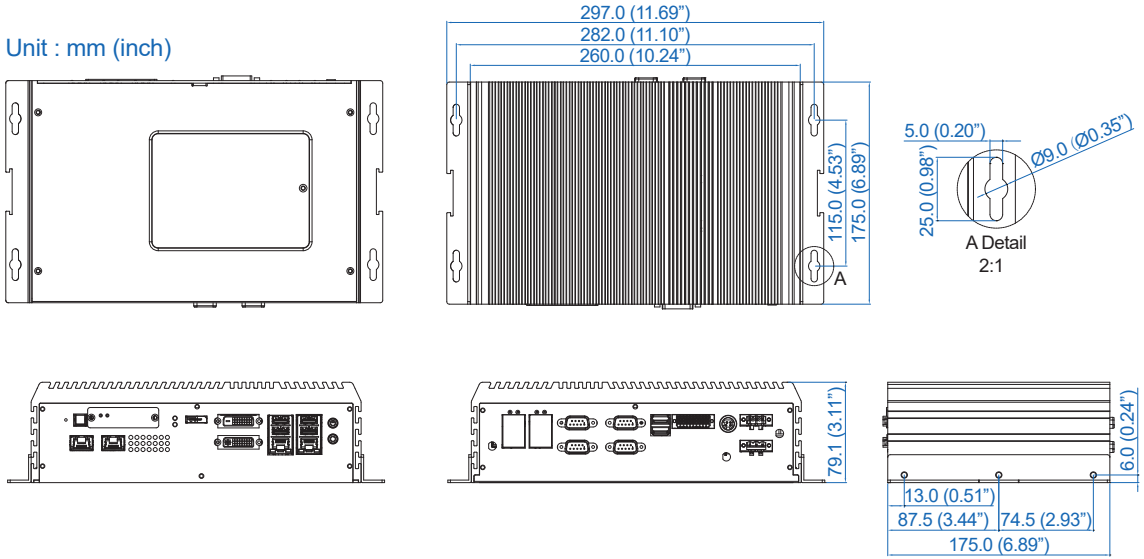

1.5.13 Dimensions of Echo 246F-10GSR

Unit : mm (inch)

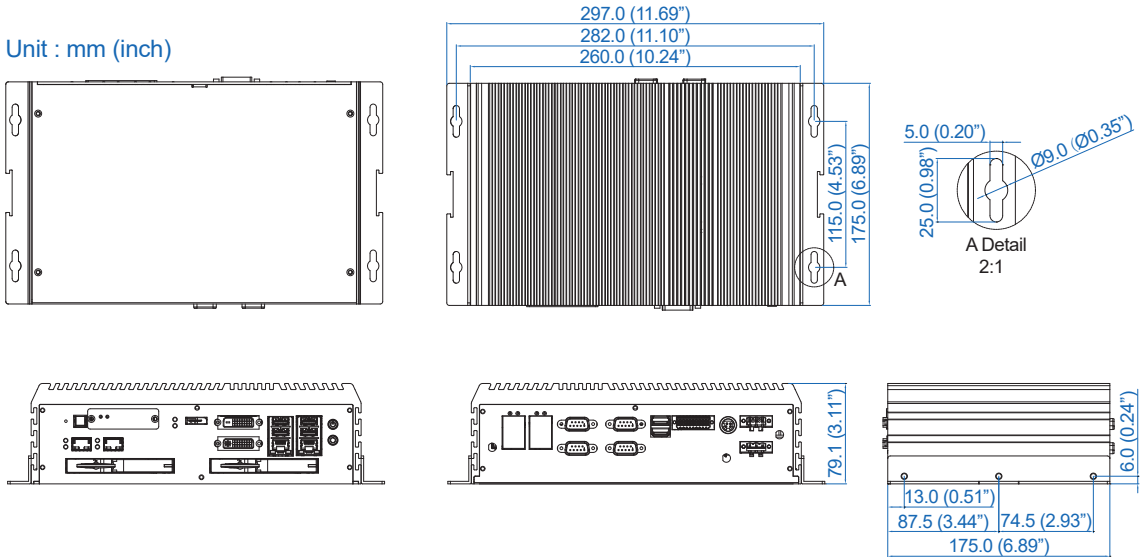

1.5.14 Dimensions of Echo 246F-10GS

Unit : mm (inch)

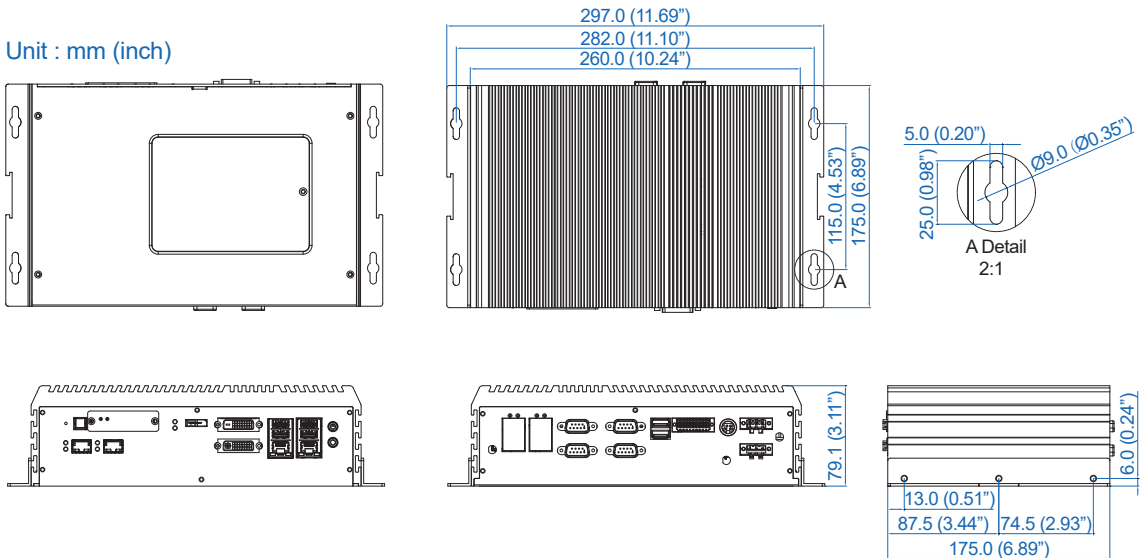

2







GETTING TO KNOW YOUR Echo 246F

2.1 Packing List

Item	Description	Qty
	Echo 246F Fanless Embedded System (According to the configuration of you order, the Echo 246F series may contain SSD/HDD and DDR4 SO-DIMM. Please verify these items if necessary.)	1
1	Echo 246F-G9/PoE/FO/G4/F/GJ/GS accessory box, which contains <ul style="list-style-type: none">• Drivers & Utilities DVD• Wall-mounting bracket• Foot Pad	1 2 4

Item	Description	Outlook	Usage	P/N	Qty
1	PHILLPIS M4x16L with washer, Ni		Mount	53-24D6416-30B	4
2	PHILLPIS M2.5x6L, Ni		Mini PCIe slot	53-2426906-30B	4
3	PHILLPIS M3x6L, Ni+Ny		M.2	53-2426206-80B	2
4	PHILLPIS #10-32x6L, Ni		Wall mount bracket	53-I000510-000	6
5	PHILLPIS M3x6L, Zn		SSD/HDD cover	53-2450000-218	8
6	Terminal block 3-pin (5.0mm)		DC-IN/Switch	51-2411R03-S1B	2
7	Terminal block 20-pin (2.54mm)		Isolated DIO/ GPIO	51-2112R20-S1D	1
8	SATA, 23cm		SSD/HDD	61-13B0707-386	1

Item	Description	Qty
	Echo 246F Fanless Embedded System (According to the configuration of you order, the Echo 246F series may contain SSD/HDD and DDR4 SO-DIMM. Please verify these items if necessary.)	1
2	Echo 246F-G9R/PoER/FOR/G4R/G/GJR/GSR accessory box, which contains <ul style="list-style-type: none"> • Drivers & Utilities DVD • Wall-mounting bracket • Foot Pad • SSD/HDD Tray Key 	1 2 4 2

Item	Description	Outlook	Usage	P/N	Qty
1	PHILLPIS M4x16L with washer, Ni		Mount	53-24D6416-30B	4
2	PHILLPIS M2.5x6L, Ni		Mini PCIe slot	53-2426906-30B	4
3	PHILLPIS M3x6L, Ni+Ny		M.2	53-2426206-80B	2
4	PHILLPIS #10-32x6L, Ni		Wall mount bracket	53-I000510-000	6
5	Terminal block 3-pin (5.0mm)		DC-IN/Switch	51-2411R03-S1B	2
6	Terminal block 20-pin (2.54mm)		Isolated DIO/ GPIO	51-2112R20-S1D	1

2.2 Front Panel I/O Functions

In Echo 246F series family, all I/O connectors are located on front panel and rear panel. Most of the general connections to computer device, such as USB, LAN Jack, DVI, DisplayPort and any additional storage, are placed on the front panel.

2.2.1 Reset Tact Switch

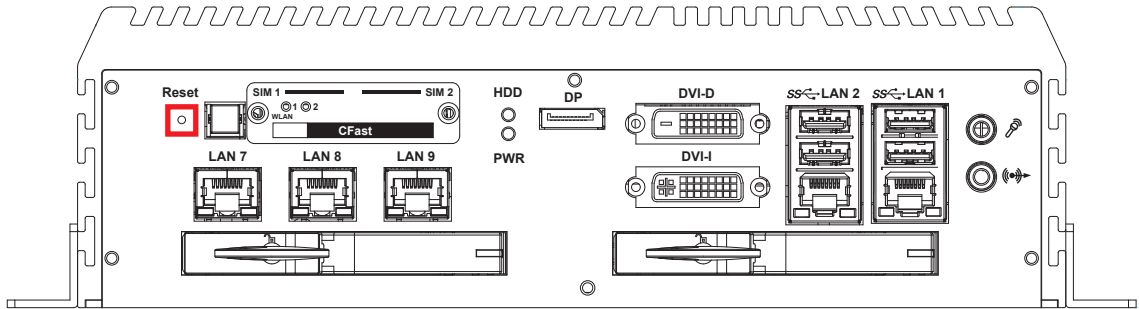

It is a hardware reset switch. Use this switch to reset the system without powering off the system. Press the Reset Switch for a few seconds, and then reset will be enabled.

2.2.2 Power Button

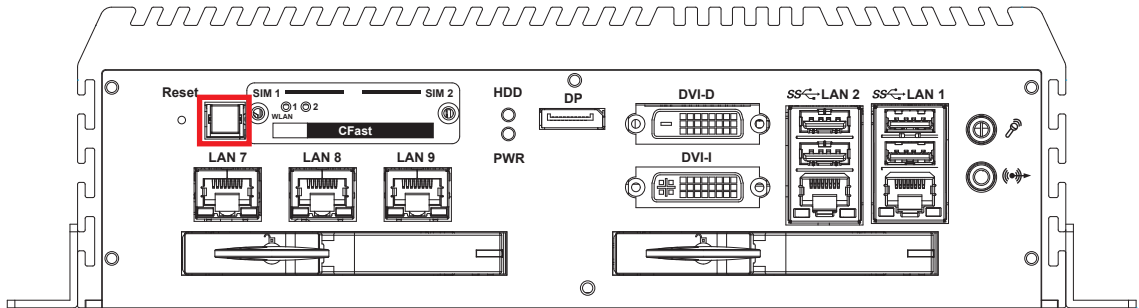

The Power Button is a non-latched switch with dual color LED indication. It indicates power status : S0, S3 and S5. More details of LED indications are listed as follows :

LED Color	Power Status	System Status
Solid Blue	S0	System working
Solid Orange	S3, S5	Suspend to RAM, System off with standby power

To power on the system, press the power button and then the blue LED is lightened. To power off the system, you can either command shutdown by OS operation, or just simply press the power button.

If a system error occurs, you can just press the power button for 4 seconds to shut down the machine directly. Please do note that a 4-second interval between each 2 power-on/power-off operation is necessary in normal working status. (For example, once you turn off the system, you have to wait for 4 seconds to initiate another power-on operation).

2.2.3 CFast Card

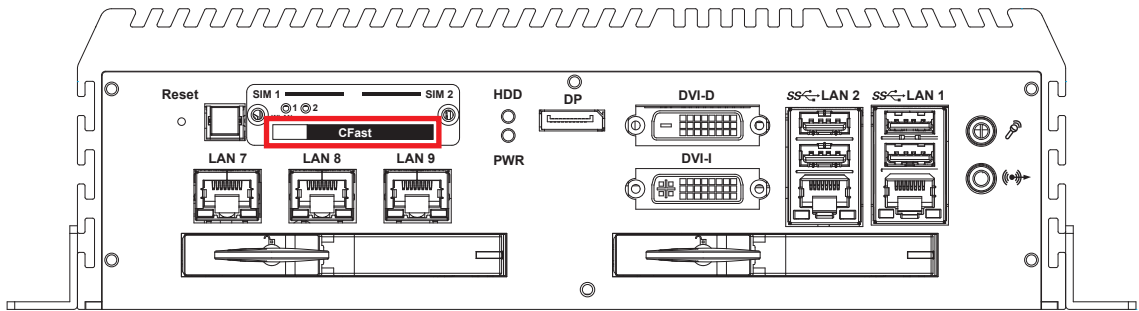

There is a CFast socket on the front panel supporting Type-I/II Compact Flash card. It is implemented by a SATA III Port from C246 PCH. Be sure to disconnect the power source and unscrew the CFast socket cover before installing a CFast card. The Echo 246F does not support the CFast hot swap and PnP (Plug and Play) functions. It is necessary to remove power source first before inserting or removing the CFast card.

The pinouts of CFast port are listed as follows :

Pin No.	Description	Pin No.	Description
S1	GND	PC6	NC
S2	SATA_TXP5	PC7	GND
S3	SATA_TXN5	PC8	CFAST_LED
S4	GND	PC9	NC
S5	SATA_RXN5	PC10	NC
S6	SATA_RXP5	PC11	NC
S7	GND	PC12	NC
PC1	GND	PC13	+3.3V
PC2	GND	PC14	+3.3V
PC3	NC	PC15	GND
PC4	NC	PC16	GND
PC5	NC	PC17	NC

2.2.4 PWR & HDD LED Indicator

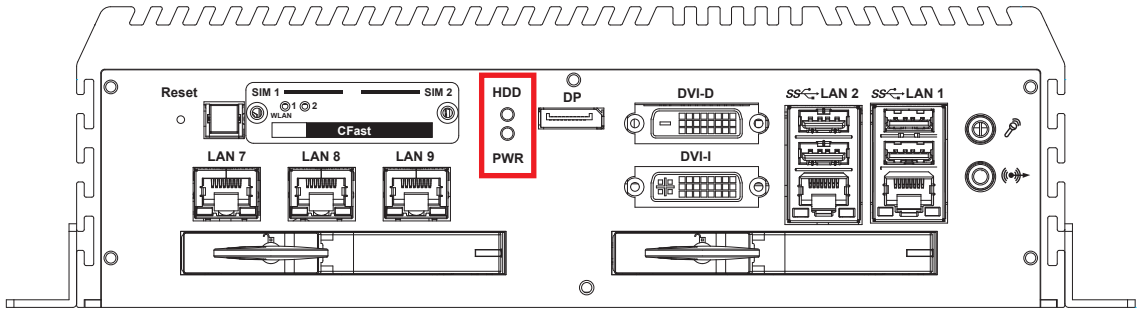

HDD LED/Yellow : A Hard Disk/CFast LED. If the LED is on, it indicates that the system's storage is functional. If it is off, it indicates that the system's storage is not functional. If it is flashing, it indicates that data access activities.

Power LED/Green : If the LED is solid green, it indicates that the system is powered on.

LED Color	Indication	System Status
Yellow	HDD/CFast	<ul style="list-style-type: none"> On/Off : Storage status, function or not. Twinkling : Data transferring.
Green	Power	System power status (on/off)

2.2.5 DVI-D Connector

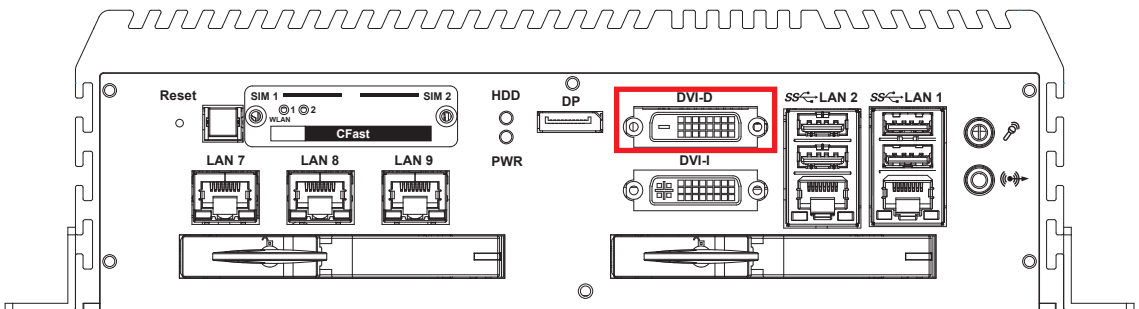

The DVI-D connector on the front panel supports DVI display. This connector can either output DVI signal. The DVI output mode supports up to 1920 x 1200 resolution and output mode supports up to 1920 x 1200 resolution. The DVI is automatically selected according to the display device connected. You will need a DVI-D cable when connecting to a display device.

2.2.6 DVI-I Connector

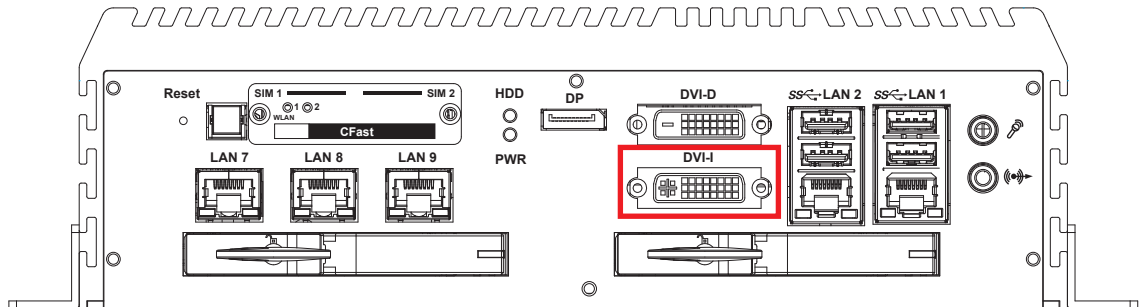

The DVI-I connector on the front panel supports both DVI and VGA display modes. This connector can output DVI signals. The DVI output mode supports up to 1920x1200 resolution. The DVI mode is automatically selected according to the display device connected. You will need a DVI-I cable when connecting to a display device. The VGA output mode supports up to 1920x1200 resolution. If use VGA function, you will need a DVII to VGA module connecting to DVI-I device. Below is the picture of a DVII to VGA module.



2.2.7 DisplayPort

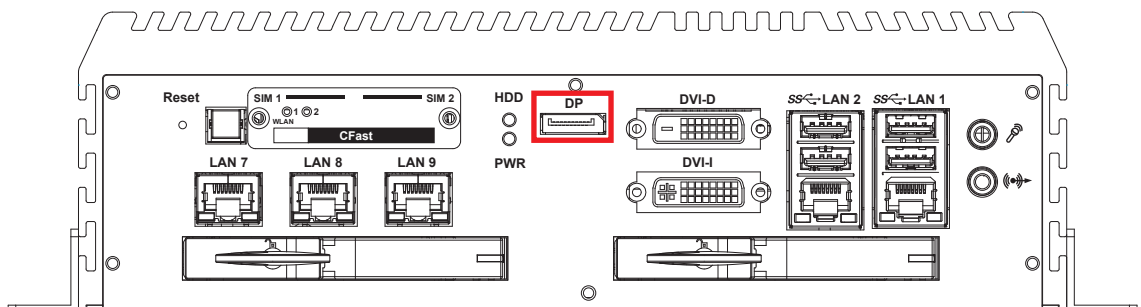

Onboard Display Port supports up to 4096x2304 resolution at 60Hz.

2.2.8 USB 3.1

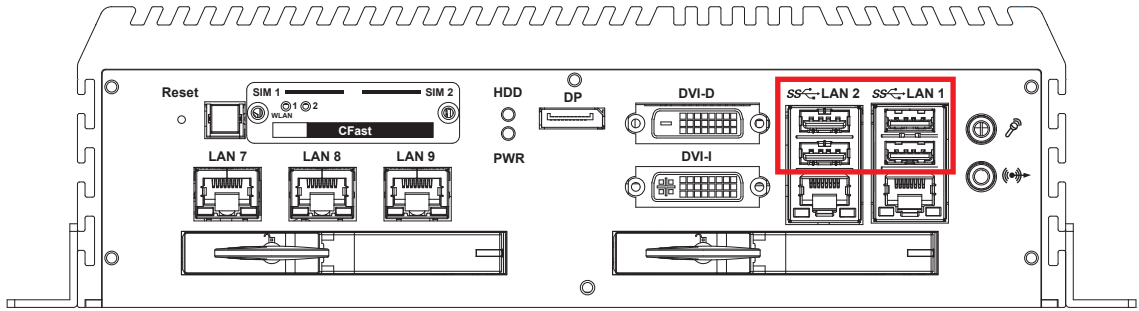

There are 4 USB 3.1 connections available supporting up to 5Gb per second data rate in the front side of Echo 246F. It is also compliant with the requirements of Super Speed (SS), high speed (HS), full speed (FS) and low speed (LS).

2.2.9 WLAN LED, Mini PCIe, SIM Card Comparison

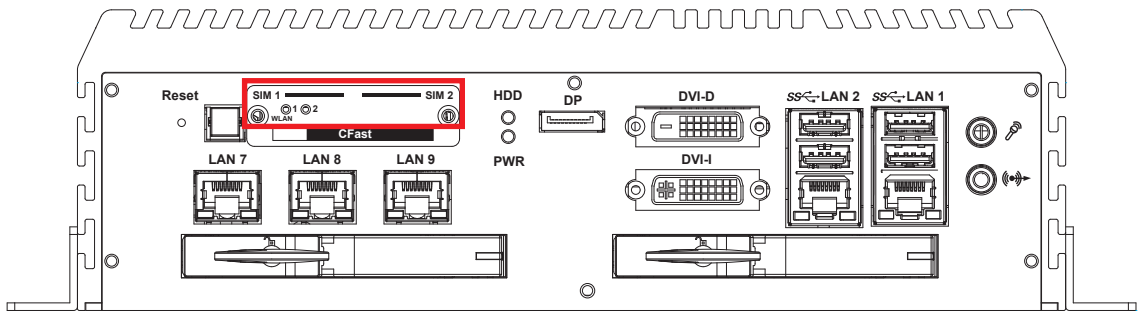

Mini PCIe Slot/SIM Slot/WLAN LED Mapping Table :

Mini PCIe	SIM	LED
MPCle 1	SIM 1 (CN9)	1
MPCle 2	SIM 2 (CN10)	2

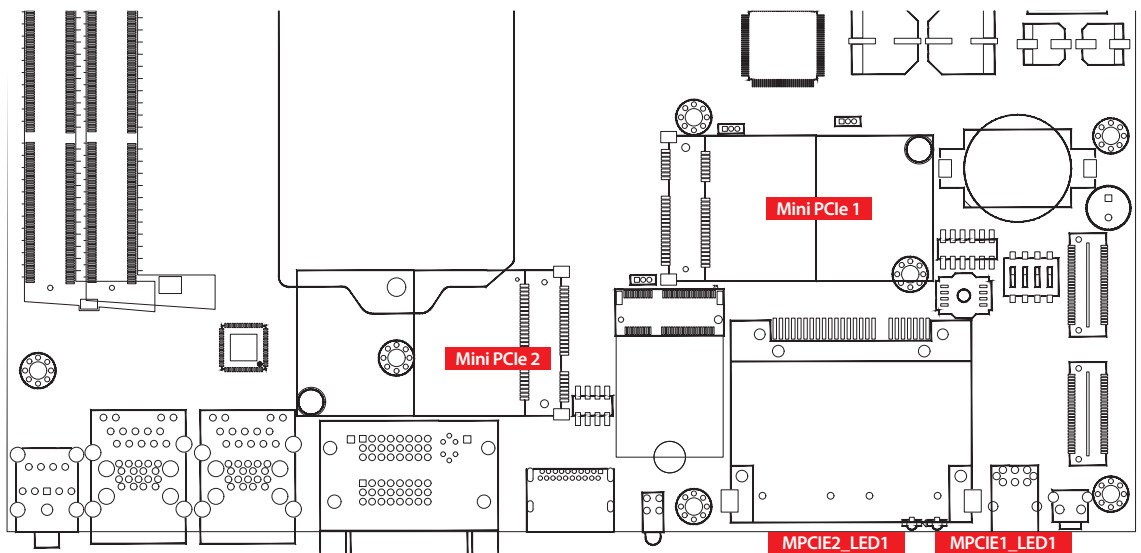

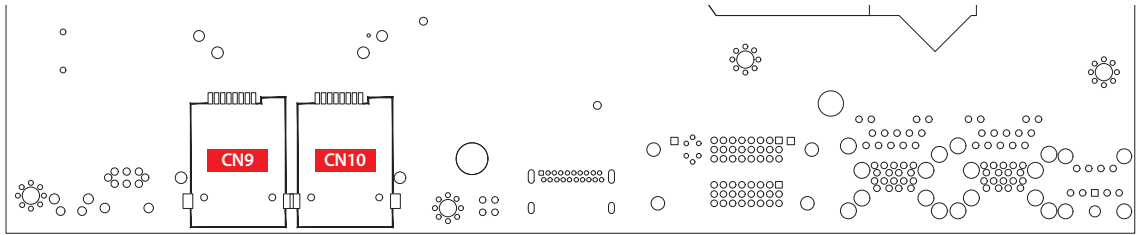

Note :

The SIM card sockets do not support hot-plug. Please make sure to unplug the system power before inserting the SIM card(s).

2.2.10 Ethernet Port

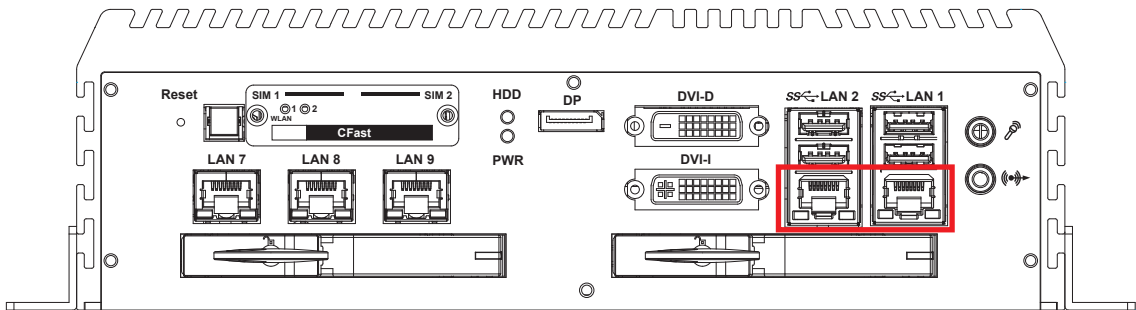

There are 2 8-pin RJ-45 jacks supporting 10/100/1000 Mbps Ethernet connections in the front side. LAN 1 is powered by Intel® i219 Ethernet Phy; LAN 2 is powered by Intel® I210 Ethernet engine. When both LAN 1 and LAN 2 work in normal status, iAMT 12.0 function is enabled.

Using suitable RJ-45 cable, you can connect the system to a computer, or to any other devices with Ethernet connection, such as hubs and switches. Moreover, both of LAN 1 and LAN 2 support Wake on LAN and Pre-boot functions. The pin-outs of LAN 1 and LAN 2 are listed as follows :

Pin No.	10/100Mbps	1000Mbps
1	E_TX+	MDI0_P
2	E_TX-	MDI0_N
3	E_RX+	MDI1_P
4	----	MDI2_P
5	----	MDI2_N
6	E_RX-	MDI1_N
7	----	MDI3_P
8	-----	MDI3_N

Each LAN port is supported by standard RJ-45 connector with LED indicators to present Active/Link/Speed status of the connection.

The LED indicator on the right bottom corner lightens in solid green when the cable is properly connected to a 100Mbps Ethernet network; The LED indicator on the right bottom corner lightens in solid orange when the cable is properly connected to a 1000Mbps Ethernet network; The left LED will keep twinkling/off when Ethernet data packets are being transmitted/received.

LED Location	LED Color	10Mbps	100Mbps	1000Mbps
Right	Green/ Orange	Off	Solid Green	Solid Orange
Left	Yellow	Twinkling Yellow	Twinkling Yellow	Twinkling Yellow

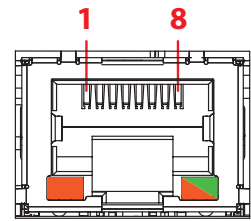

2.2.11 Audio Connector

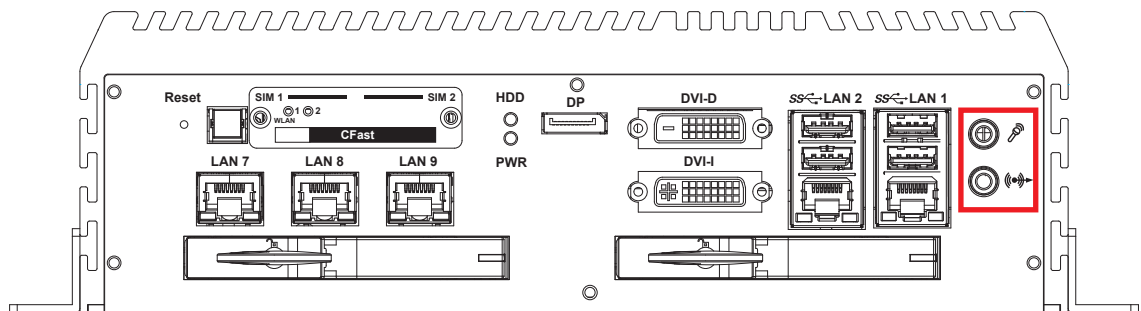

There are 2 audio connectors, Mic-in and Line-out in the front side of Echo 246F. Onboard Realtek ALC892 audio codec supports 5.1 channel HD audio and fully complies with Intel® High Definition Audio (Azalia) specifications.

To utilize the audio function in Windows platform, you need to install corresponding drivers for both Intel Sunrise Point chipset and Realtek ALC892 codec.

2.2.12 SSD/HDD Tray

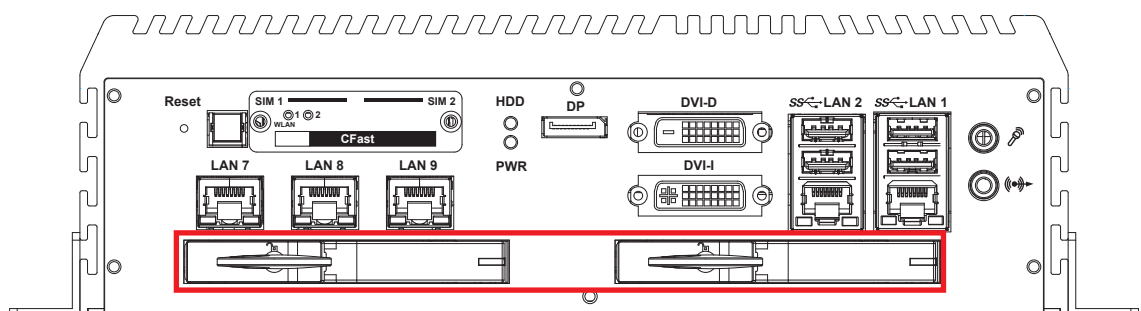

There are 2 front-access 2.5" SSD/HDD trays in the front side of Echo 246F. Just pull the trigger to open the SSD/HDD tray.

2.2.13 Expansion Ethernet

2.2.13.1 1G Ethernet Port (G9R/G9)

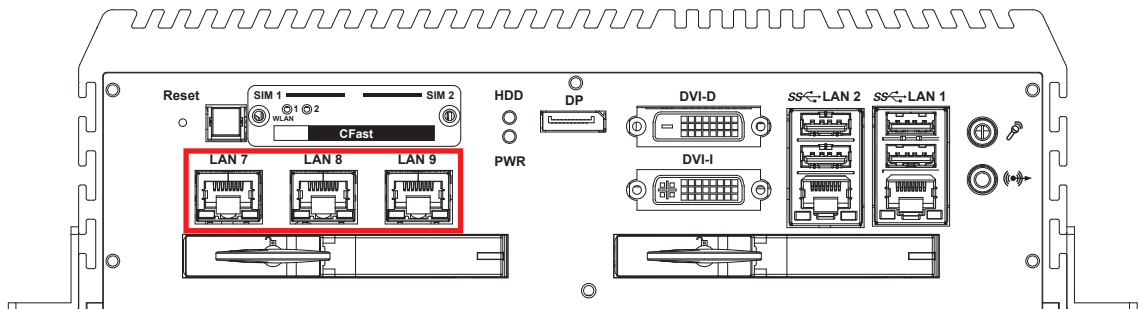

There are 3 expansion 8-pin RJ-45 jacks supporting 10/100/1000 Mbps Ethernet connections in the front side. LAN 7, 8, 9 are powered by Intel® 82574.

- IEEE 802.3ab Gigabit Ethernet standard compliant
- IEEE 1588 Precision Time Protocol (PTP)
- Up to 9KB Jumbo Frame
- Triple independent GigE LAN Connection
- Supports Wake-on-LAN (WoL) & PXE

2.2.13.2 1G Fiber Port (FOR/FO)

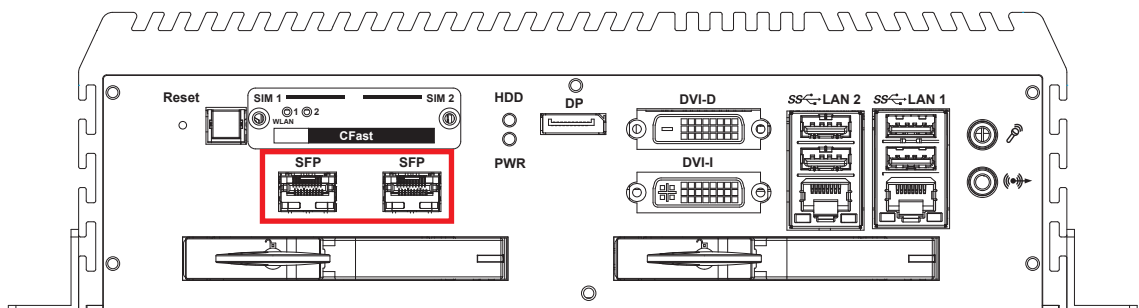

There are 2 expansion SFP Fiber LAN, powered by Intel® I350, in the front side.

- Intel® I350 Gigabit Ethernet Controller supports 1Gbps data rate
- IEEE 802.3 Fast Ethernet over optical fiber standard compliant
- IEEE 1588 Precision Time Protocol (PTP)
- Up to 9.5KB Jumbo Frame
- Dual 100BASE-FX fiber ports
- Supports Wake-on-LAN (WoL) & PXE

2.2.13.3 10G Ethernet Port (10GJR/10GJ)

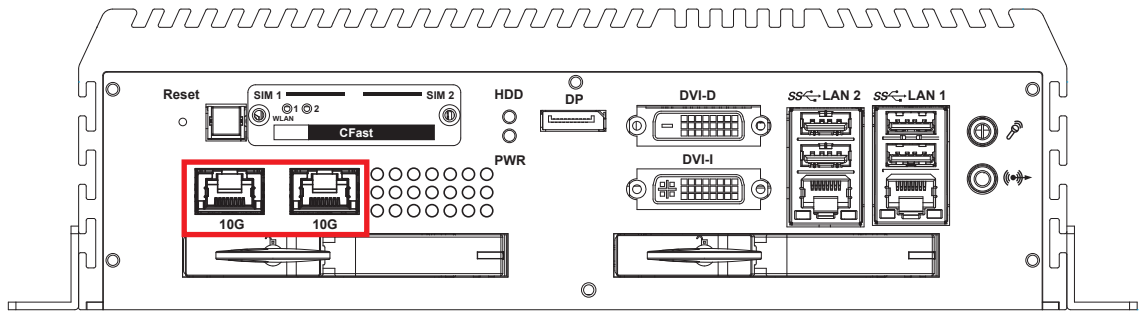

There are 2 expansion 10G ethernet LAN, powered by Intel® X550-AT2, in the front side.

- Intel® X550-AT2 10GBASE-T controller supports up to 10Gbps data rate
- IEEE 802.3an Fast Ethernet standard compliant
- IEEE 1588 Precision Time Protocol (PTP)
- Up to 9728 bytes Jumbo Frame, Link Aggregation
- Supports Wake-on-LAN (WoL) & PXE
- Intel® Ethernet Power Management
- Intel® Data Direct I/O Technology
- Intel® Virtualization Technology for Connectivity (VT-c)

2.2.13.4 10G Fiber Port (10GSR/10GS)

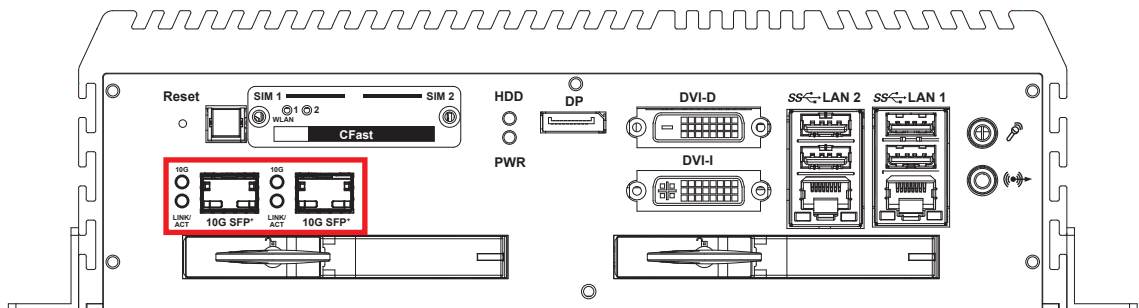

There are 2 expansion 10G fiber, powered by Intel® X710-BM2, in the front side.

- Intel® X710-BM2 Dual Port 10Gigabit Ethernet Controller supports up to 10Gbps data rate
- IEEE 802.3 Fast Ethernet over optical fiber standard compliant
- IEEE 1588 Precision Time Protocol (PTP)
- Up to 9728 bytes Jumbo Frame, Link Aggregation
- Supports Wake-on-LAN (WoL) & PXE
- Intel® Ethernet Power Management
- Intel® Data Direct I/O Technology
- -25°C to 55°C Operating Temperature

2.3 Rear Panel I/O & Functions

2.3.1 Power Terminal Block

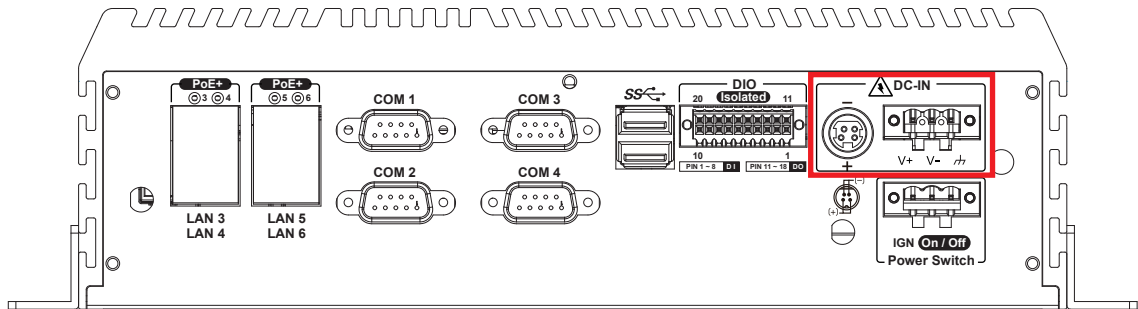

Echo 246F supports 6V to 36V DC power input by terminal block in the rear side. In normal power operation, power LED lightens in solid green. Echo 246F supports up to 80V surge protection.

Pin No.	Definition	Pin No.	Definition
1	V+	2	V-
3	Chassis Ground		

2.3.2 Remote Power On/Off Switch & LED Terminal Block

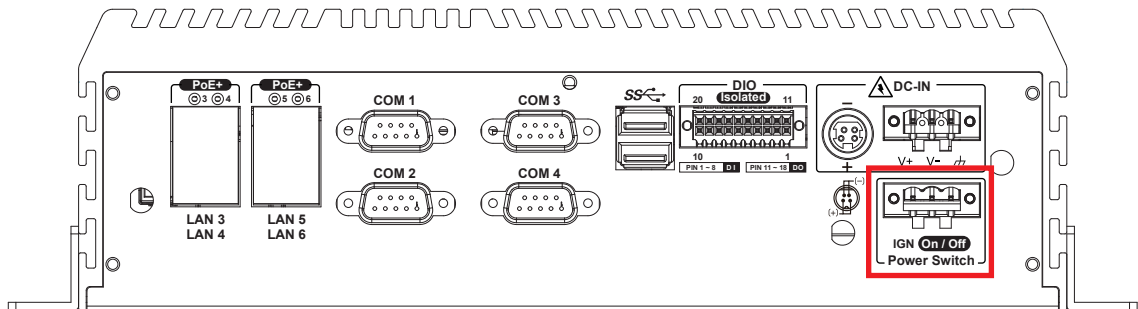

It is a 2-pin power-on or power-off switch through Phoenix Contact terminal block. You could turn on or off the system power by using this contact. This terminal block supports dual function of soft power-on/power-off (instant off or delay 4 second), and suspend mode.

Pin No.	Definition	Pin No.	Definition
1	Ignition	2	SW+
3	SW-		

2.3.3 Isolated DIO/GPIO

2.3.3.1 Isolated DIO

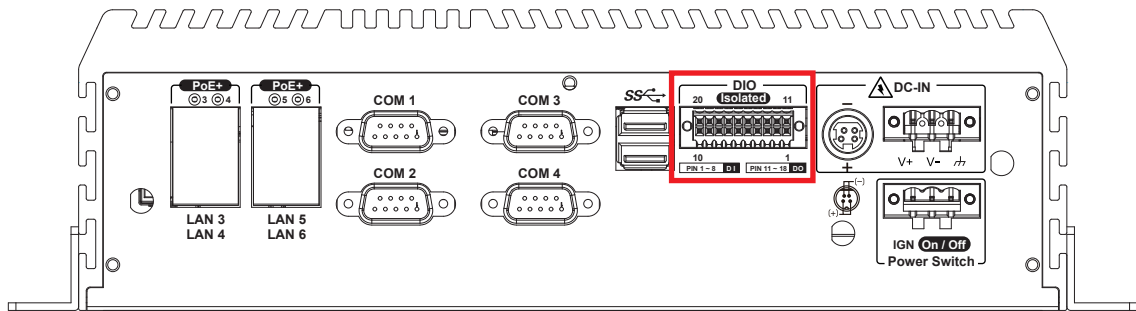

There is a 16-bit (8-bit DI, 8-bit DO) connectors in the rear side. DI/DIO support NPN (sink) and PNP (Source) mode, Each DI pin is equipped with a photocoupler for isolated protection. Each DO pin is equipped with isolator function, DO Safety-Related Certifications :

- 4242-VPK Basic Isolation per DIN V VDE V 0884-10 and DIN EN 61010-1
- 3-KVRMS Isolation for 1 minute per UL 1577
- CSA Component Acceptance Notice 5A, IEC 60950-1 and IEC 61010-1 End Equipment Standards
- GB4943.1-2011 CQC Certified

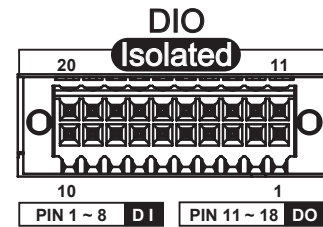

DIO Connectors pin out :

DIO	Pin No.	Definition	Function
DIO	1	INPUT 0	SIO_GPI70
	2	INPUT 1	SIO_GPI71
	3	INPUT 2	SIO_GPI72
	4	INPUT 3	SIO_GPI73
	5	INPUT 4	SIO_GPI74
	6	INPUT 5	SIO_GPI75
	7	INPUT 6	SIO_GPI76
	8	INPUT 7	SIO_GPI77
	9	DI_COM	-
	10	DIO_GND	-
	11	OUTPUT 0	SIO_GPO80
	12	OUTPUT 1	SIO_GPO81
	13	OUTPUT 2	SIO_GPO82
	14	OUTPUT 3	SIO_GPO83
	15	OUTPUT 4	SIO_GPO84
	16	OUTPUT 5	SIO_GPO85
	17	OUTPUT 6	SIO_GPO86
	18	OUTPUT 7	SIO_GPO87
	19	DIO_GND	-
	20	External 6-40VDC (NPN) External 6-48VDC (PNP)	-

DI reference circuit :

Sink Mode (NPN)

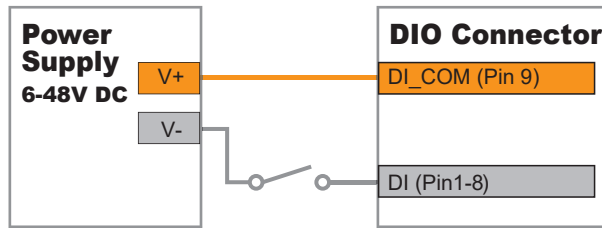

Source Mode (PNP)

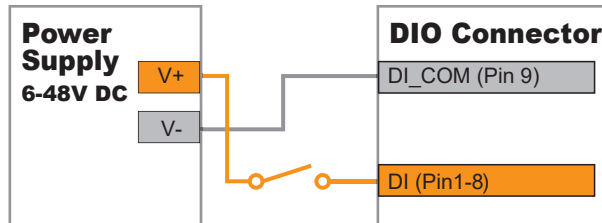

DO reference circuit :

Sink Mode (NPN, Default)

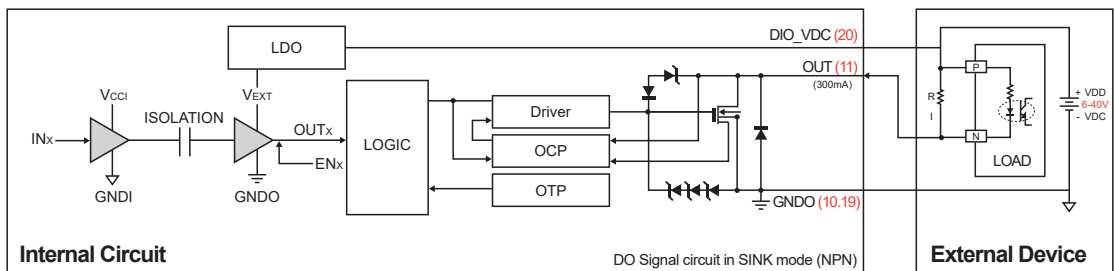

Source (PNP)

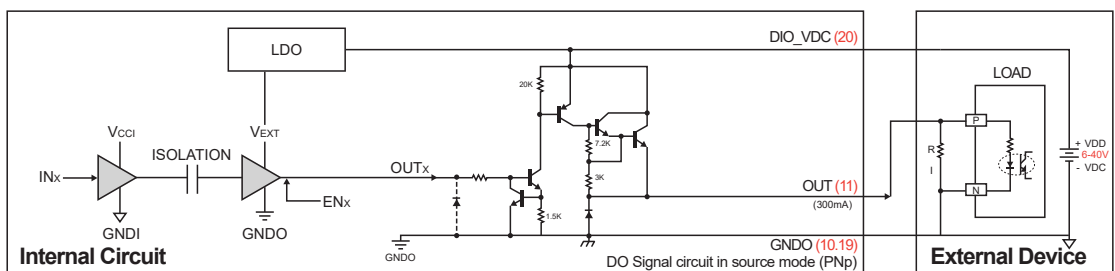

2.3.3.2 GPIO

The system offers sixteen programmable I/O. (3.3V Level)

If the GPIO is logic high, it indicates that the mapping SIO GPIO pin is logic high level.
If the GPIO is logic low, it indicates that the mapping SIO GPIO pin is logic low level.

GPIO Connectors pin assignments

Pin No.	Definition	Pin No.	Definition
1	SIO_GPI70	11	SIO_GPO80
2	SIO_GPI71	12	SIO_GPO81
3	SIO_GPI72	13	SIO_GPO82
4	SIO_GPI73	14	SIO_GPO83
5	SIO_GPI74	15	SIO_GPO84
6	SIO_GPI75	16	SIO_GPO85
7	SIO_GPI76	17	SIO_GPO86
8	SIO_GPI77	18	SIO_GPO87
9	-----	19	-----
10	-----	20	-----

2.3.4 USB Port

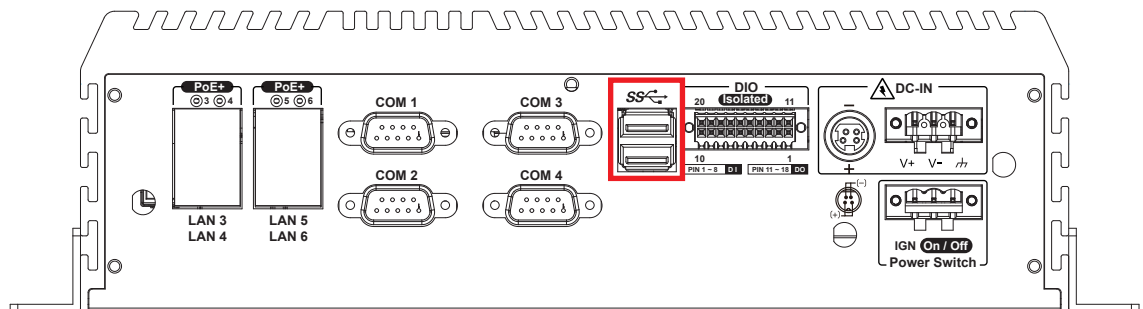

There are 2 USB 3.1 connections available supporting up to 5Gb per second data rate in the rear side of Echo 246F. It is also compliant with the requirements of Super Speed (SS), high speed (HS), full speed (FS) and low speed (LS).

2.3.5 Serial Port

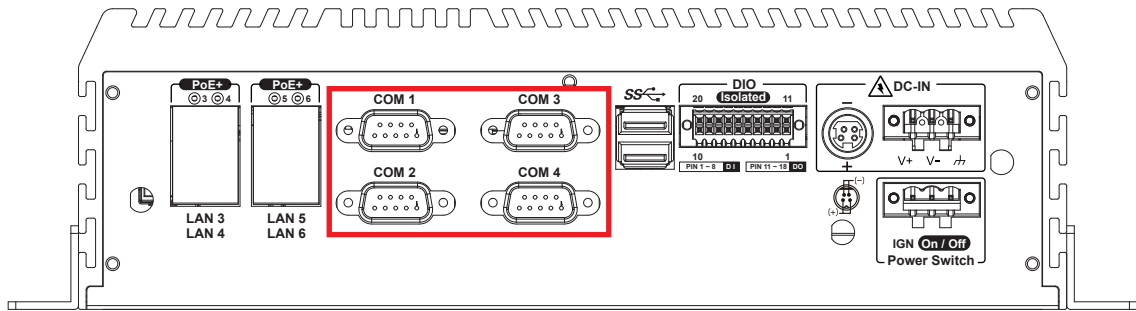

Serial port 1 to 4 (COM 1 to 4) can be configured for RS-232, RS-422, or RS-485 with auto flow control communication. The default definition of COM 1 and COM 2 is RS-232. If you want to change to RS-422 or RS-485, you can find the setting in BIOS.

BIOS Setting	Function
COM 1	RS-232
COM 2	RS-422 (5-wire)
COM 3	RS-422 (9-wire)
COM 4	RS-485
	RS-485 w/z auto-flow control

The pin assignments are listed in the following table :

Serial Port	Pin No.	RS-232	RS-422 (5-wire)	RS-422 (9-wire)	RS-485 (3-wire)
1 to 4	1	DCD	TXD-	TXD-	DATA-
	2	RXD	TXD+	TXD+	DATA+
	3	TXD	RXD+	RXD+	-----
	4	DTR	RXD-	RXD-	-----
	5	GND	GND	GND	GND
	6	DSR	-----	RTS-	-----
	7	RTS	-----	RTS+	-----
	8	CTS	-----	CTS+	-----
	9	RI	-----	CTS-	-----

2.3.6 PoE Ports

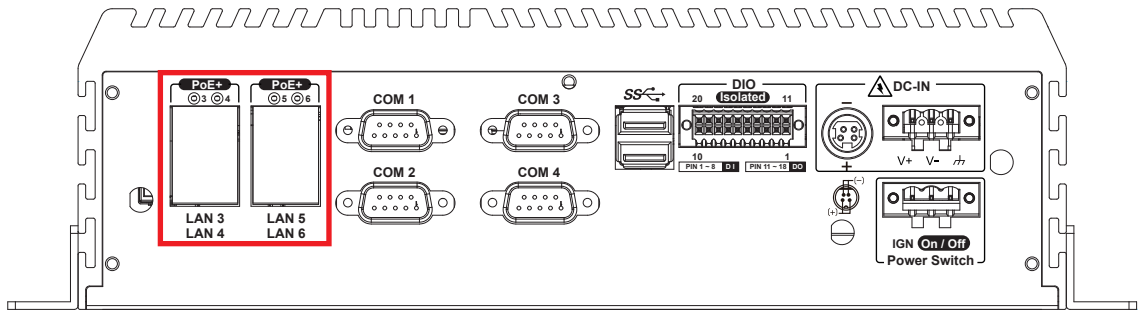

There are 4 RJ45 connectors in the rear side of Echo 246F. It supports IEEE 802.3at (PoE⁺) Power over Ethernet (PoE) connection delivering up to 37W/54V per port and 1000BASE-T gigabit data signals over standard Ethernet Cat 5/Cat 6 cable.

Each PoE connection is powered by Intel[®] I210 Gigabit Ethernet controller and independent PCI express interface to connect with multi-core processor for network and data transmit optimization. Only when PoE port starts to supply power to power devices, the dedicated LED will be lightened.

PS. Suggest to use PoE function when power input is over 12V.

The pin-outs of LAN 3 and LAN 6 are listed as follows :

Pin No.	10/100Mbps	1000Mbps	PoE
1	E_TX+	MDI0_P	PoE+
2	E_TX-	MDI0_N	PoE+
3	E_RX+	MDI1_P	PoE-
4	-----	MDI2_P	----
5	-----	MDI2_N	----
6	E_RX-	MDI1_N	PoE-
7	-----	MDI3_P	----
8	-----	MDI3_N	----

Each LAN port is supported by standard RJ-45 connector with LED indicators to present Active/Link/Speed status of the connection.

The LED indicator on the right bottom corner lightens in solid green when the cable is properly connected to a 100 Mbps Ethernet network; The LED indicator on the right bottom corner lightens in solid orange when the cable is properly connected to a 1000 Mbps Ethernet network; The left LED will keep twinkling/off when Ethernet data packets are being transmitted/received.

LED Location	LED Color	10 Mbps	100 Mbps	1000 Mbps
Right	Green/ Orange	Off	Solid Green	Solid Orange
Left	Yellow	Twinkling Yellow	Twinkling Yellow	Twinkling Yellow

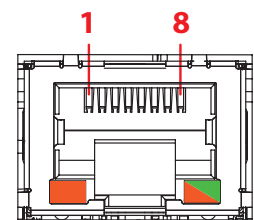

POE LED	LED Color	POE Status
LED 3 - 6	Solid Green	POE ON

2.4 Main Board Expansion Connectors

2.4.1 Top View (Component Side) of Echo 246F Main Board With Connector Location

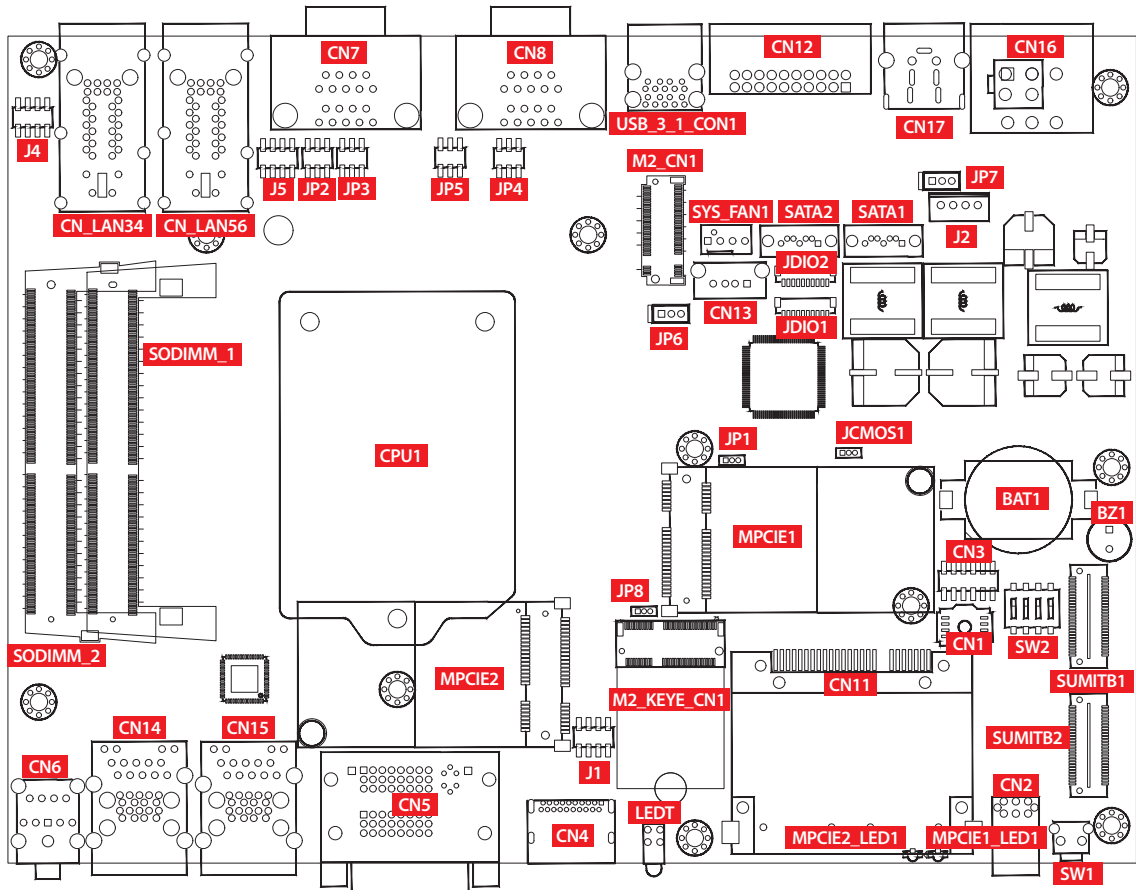

2.4.2 Bottom View (Solder Side) of Echo 246F Main Board With Connector Location

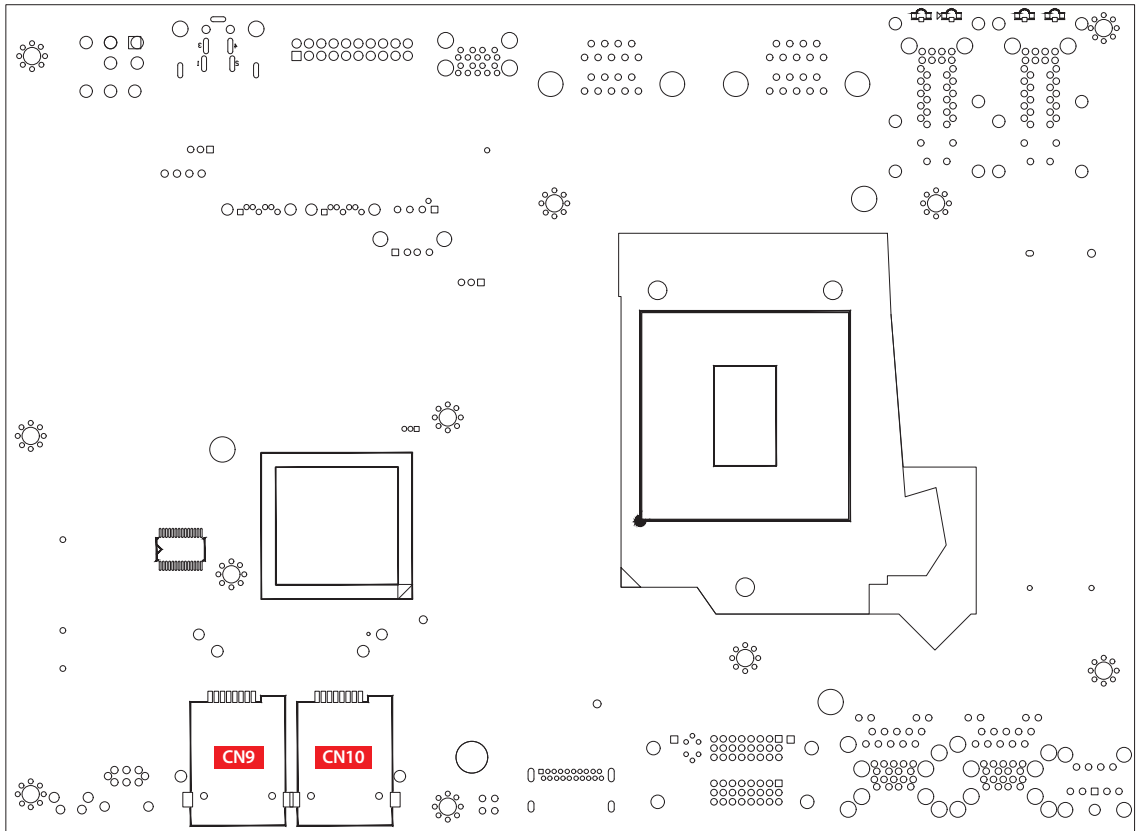

2.4.3 J1 : Miscellaneous Pin Header

This pin header can be used as a backup for following functions, such as hard drive LED indicator, reset button, power LED indicator, and power-on/off button, which already can be accessed by front panel and top panel. The pin-outs of Miscellaneous port are listed in following table :

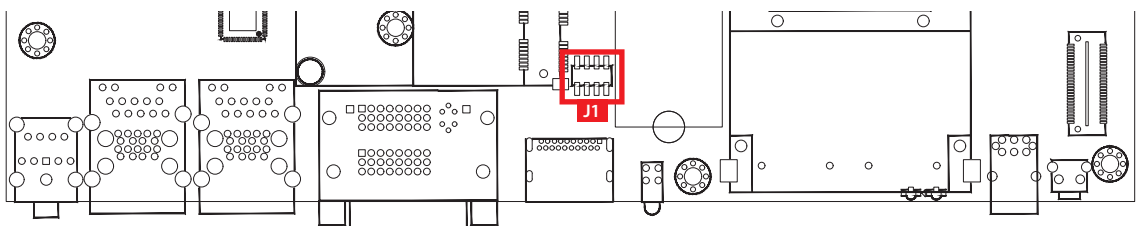

	Group	Pin No.	Description
	HDD LED	1	HDD_LED_P
		3	HDD_LED_N
	RESET BUTTON	5	FP_RST_BTN_N
		7	Ground
	POWER LED	2	PWR_LED_P
		4	PWR_LED_N
	POWER BUTTON	6	FP_PWR_BTN_IN
		8	Ground

2.4.4 SATA1, SATA2 : SATA III Connector

There are 2 onboard high performance Serial ATA III (SATA III) on Echo 246F. It supports higher storage capacity with less cabling effort and smaller required space. The pin assignments of SATA1 and SATA2 are listed in the following table :

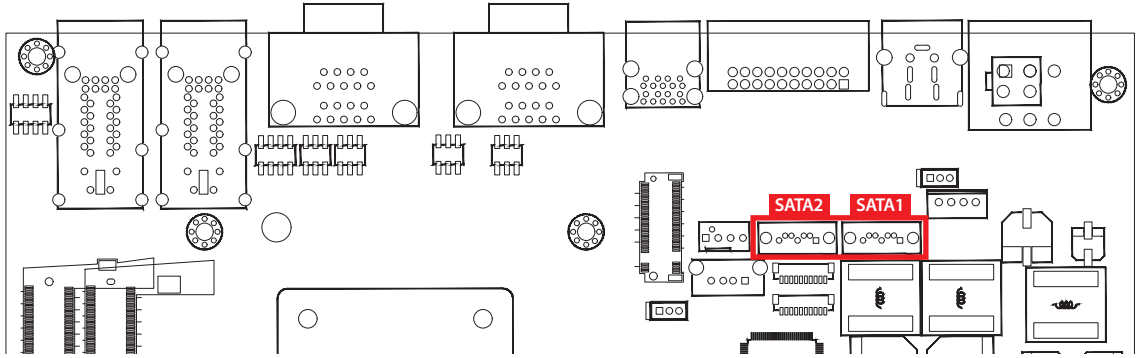

	Pin No.	Definition	Pin No.	Definition
	1	GND	5	RXN
	2	TXP	6	RXP
	3	TXN	7	GND
	4	GND		

2.4.5 J2 : SATA Power Connector

The Echo 246F also equips with a SATA power connector. The one port supports 5V (Up to 2A) and 12V (Up to 2A) to the hard drive or SSD. The pin assignments of J2 are listed in the following table :

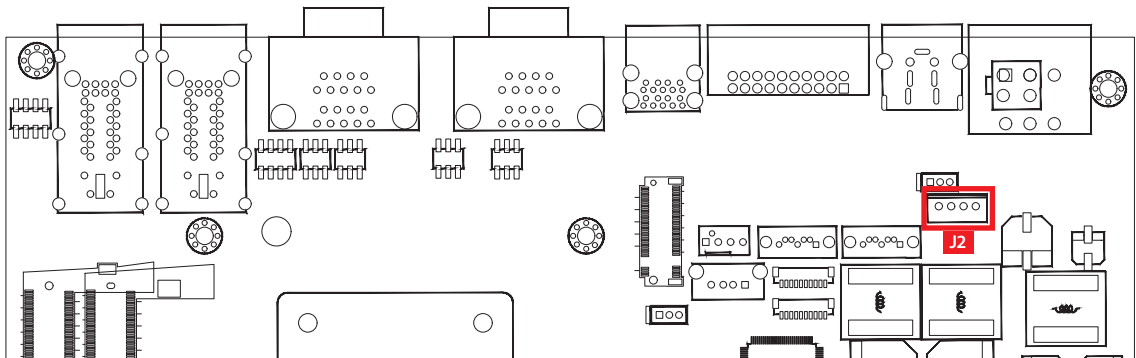

	Pin No.	Definition	Pin No.	Definition
	1	+12V	3	GND
	2	GND	4	+5V

2.4.6 CN13 : Internal USB

The USB 2.0 connections supports up to 480Mbps. It is also compliant with the requirements of high speed (HS), full speed (FS) and low speed (LS). The pin assignments of CN13 are listed in the following table :

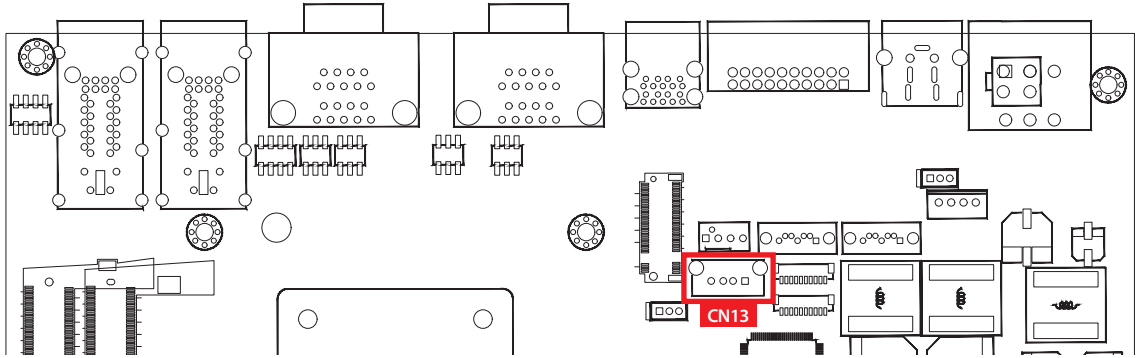

	Pin No.	Definition	Pin No.	Definition
	1	+5V	3	D+
	2	D-	4	GND

2.4.7 SODIMM_1, SODIMM_2 : DDR4 Slot

There are 2 DDR4 channel onboard, supporting DDR4 2666, max 64GB
Each channel supports up to 32GB.

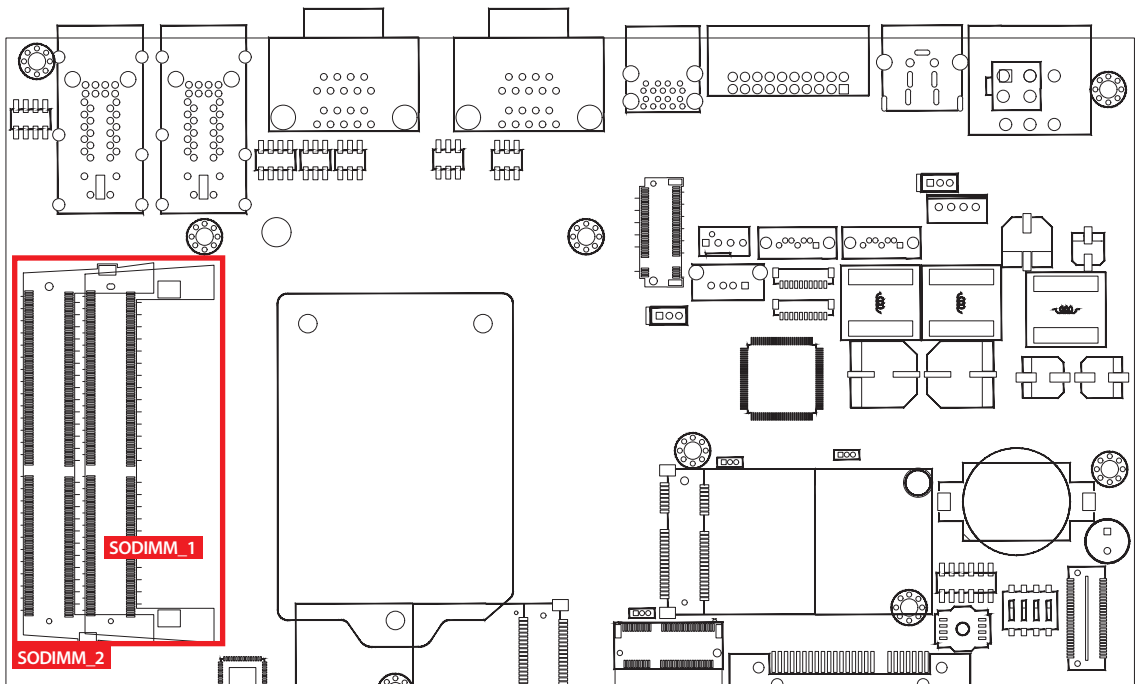

Slot	Description
SODIMM_1	DDR4 Channel A
SODIMM_2	DDR4 Channel B

2.4.8 CN1 : BIOS Socket

If the BIOS needs to be changed, please contact the RMA service team.

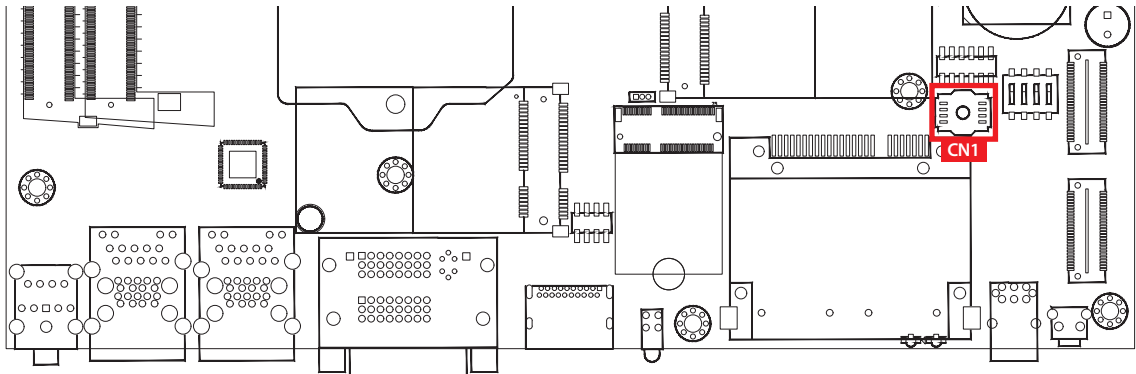

2.4.9 SUMIT A, SUMIT B

This system have standard SUMIT A and SUMIT B for SUMIT type add-on cards.

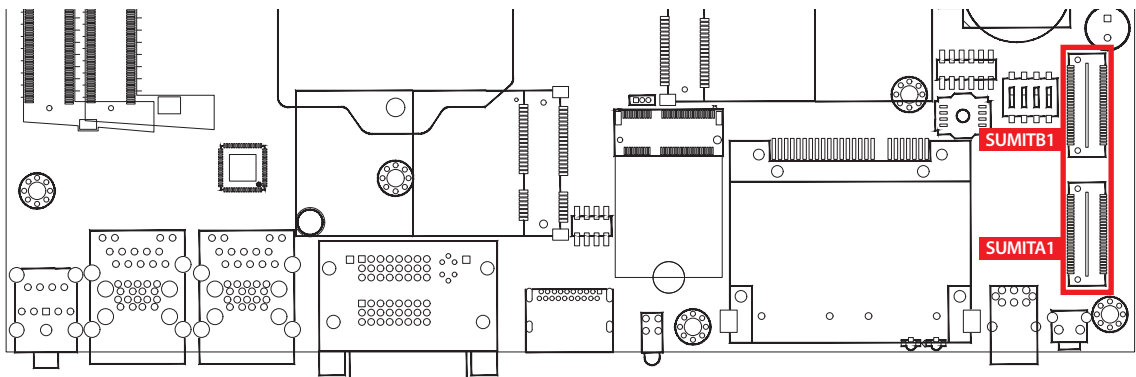

SUMIT A Pin Out :

Pin No.	Function	Pin No.	Function
1	+5V_AUX	2	+12V
3	+3.3V	4	SMB_DATA
5	+3.3V	6	XMB_CLK
7	Reserved	8	Reserved
9	Reserved	10	SPI_MISO
11	USB_OC#	12	SPI_MOSI
13	Reserved	14	SPI_CLK
15	+5V	16	SPI_CS10
17	USB_3+	18	SPI_CS1#
19	USB_3-	20	Reserved
21	+5V	22	LPC_DRQ1#
23	USB_2+	24	LPC_AD0
25	USB_2-	26	LPC_AD1

Pin No.	Function	Pin No.	Function
27	+5V	28	LPC_AD2
29	USB_1+	30	LPC_AD3
31	USB_1-	32	LPC_FRAME#
33	+5V	34	SERIRQ#
35	USB_0+	36	Reserved
37	USB_0-	38	CLK_33MHz
39	GND	40	GND
41	A_PET_P0	42	A_PER_P0
43	A_PET_N0	44	A_PER_N0
45	GND	46	APRSNT#/A_PE_CLKREQ#
47	PERST#	48	A_CLKP
49	WAKE#	50	A_CLKN
51	+5V	52	GND

SUMIT B Pin Out :

Pin No.	Function	Pin No.	Function
1	GND	2	GND
3	B_PET_P0	4	B_PER_P0
5	B_PET_N0	6	B_PER_N0
7	GND	8	GND
9	C_CLKP	10	B_CLKP
11	C_CLKN	12	B_CLKN
13	CPRSNT#/C_PE_CLKREQ#	14	GND
15	C_PET_P0	16	C_PER_P0
17	C_PET_N0	18	C_PER_N0
19	GND	20	GND
21	C_PET_P1	22	C_PER_P1
23	C_PET_N1	24	C_PER_N1
25	GND	26	GND
27	C_PET_P2	28	C_PER_P2
29	C_PET_N2	30	C_PER_N2
31	GND	32	GND
33	C_PET_P3	34	C_PER_P3
35	C_PET_N3	36	C_PER_N3
37	GND	38	GND
39	PERST#	40	WAKE#
41	Reserved	42	Reserved
43	+5V	44	Reserved
45	+5V	46	+3.3V
47	+5V	48	+3.3V
49	+5V	50	+3.3V
51	+5V	52	+5V_AUX

2.4.10 Mini PCIe : MPCle_1 , MPCle_2

Standard full length mini PCIe slot

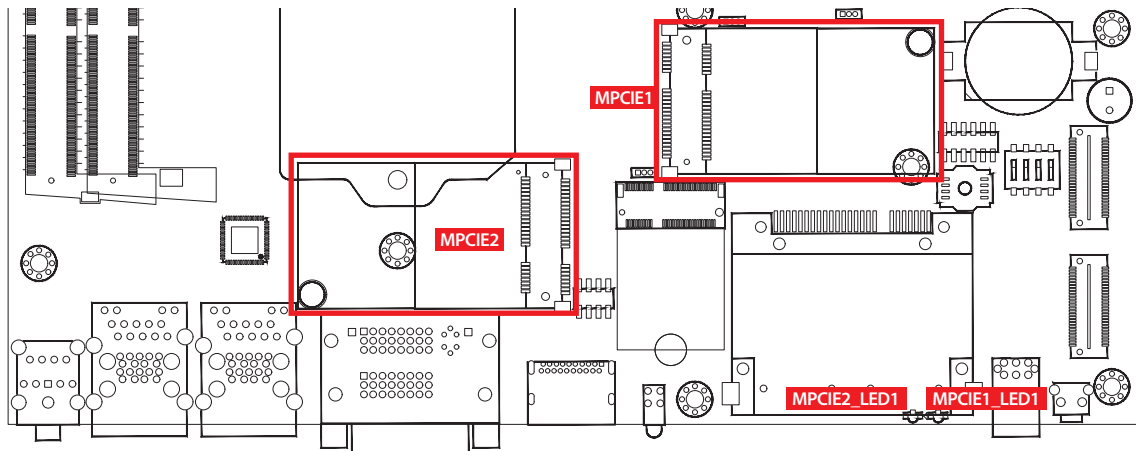

The pin assignments of MPCle 1, MPCle 2 ted in the following table :

Pin No.	Signal Name	Pin No.	Signal Name
51	Reserved	52	+3.3Vaux
49	Reserved	50	GND
47	Reserved	48	+1.5V
45	Reserved	46	Reserved
43	GND	44	Reserved
41	+3.3Vaux	42	Reserved
39	+3.3Vaux	40	GND
37	GND	38	USB_D+
35	GND	36	USB_D-
33	PETp0	34	GND
31	PETn0	32	SMB_DATA
29	GND	30	SMB_CLK
27	GND	28	+1.5V
25	PERp0	26	GND
23	PERn0	24	+3.3Vaux
21	GND	22	PERST#
19	Reserved	20	reserved
17	Reserved	18	GND
Mechanical Key			
15	GND	16	UIM_VPP
13	REFCLK+	14	UIM_RESET
11	REFCLK-	12	UIM_CLK
9	GND	10	UIM_DATA
7	CLKREQ#	8	UIM_PWR
5	Reserved	6	1.5V
3	Reserved	4	GND
1	WAKE#	2	3.3Vaux

2.4.11 BAT1 : RTC Battery

The system's real-time clock is powered by a lithium battery. It is equipped with Panasonic BR2032 190mAh lithium battery. It is recommended that you shouldn't replace the lithium battery on your own. If the battery needs to be changed, please contact the RMA service team.

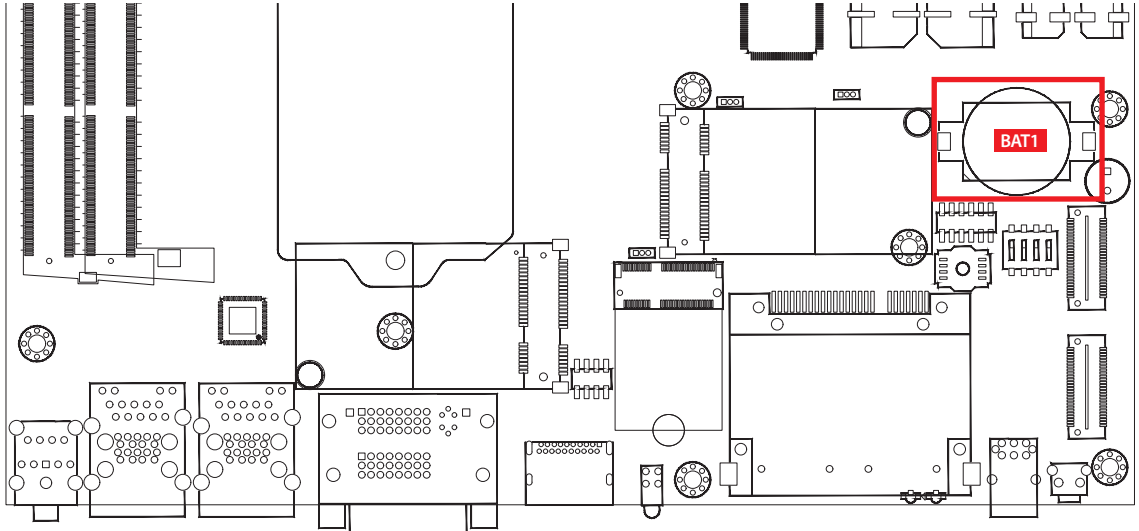

2.4.12 FN1 : FAN Header

Fan power connector supports for additional thermal requirements. The pin assignments of FAN 1 are listed in the following table.

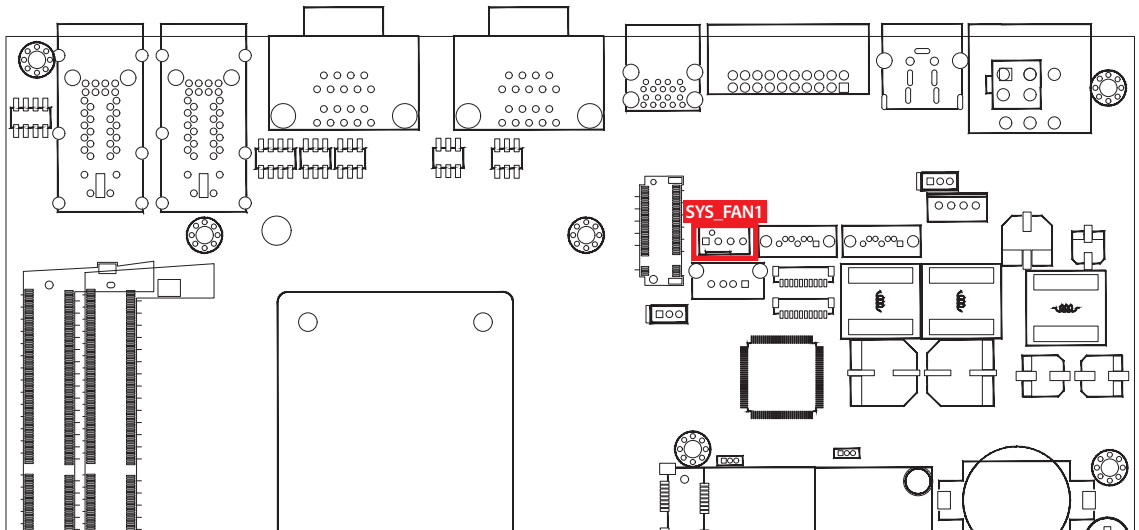

	Pin No.	Definition	Pin No.	Definition
	1	GND	3	Fan speed sensor
	2	+12V (1.5A max)	4	Fan PWM

2.4.13 CN3 : LPC Port 80 Header

Echo 246F provides a LPC Port 80 Header for Debug Card.

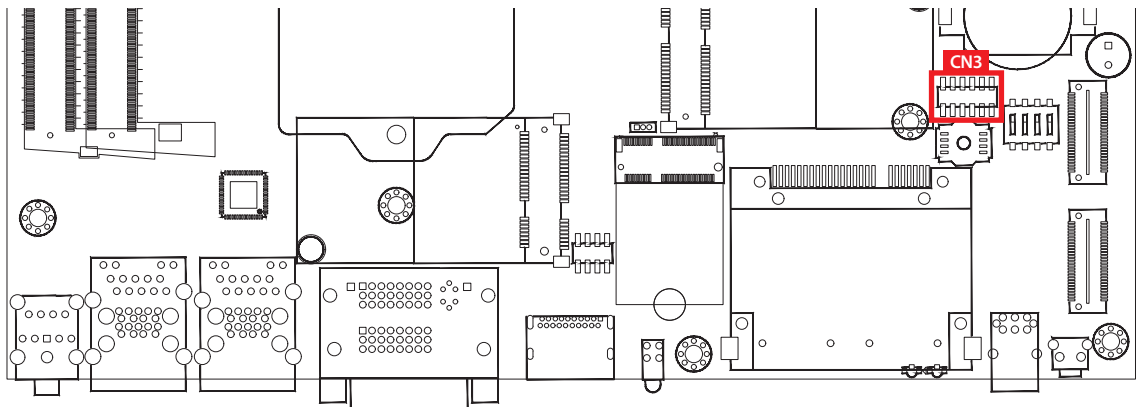

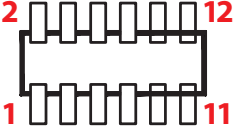
	Pin No.	Definition	Pin No.	Definition
		1	SERIRQ	7
	2	+3.3V	8	LAD0
	3	LA3	9	N/C
	4	RESET#	10	Ground
	5	LAD1	11	CLOCK
	6	LAD2	12	Ground

2.4.14 J4, J5 : LAN3, LAN4, LAN5, LAN6 Speed LED Header

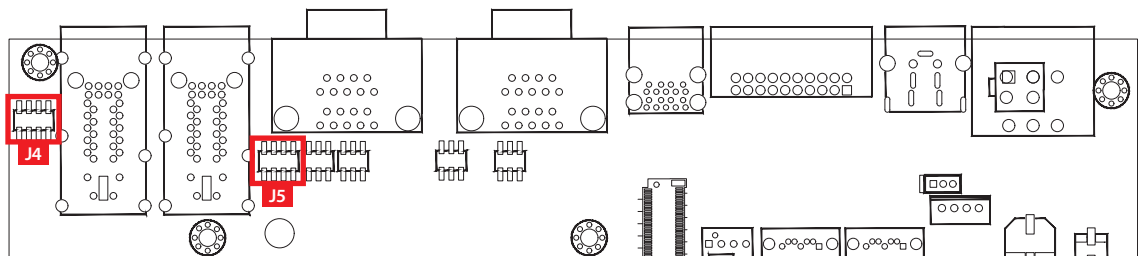

J4 Pin Out :

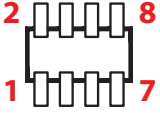
	
Pin Number	LAN PORT/Function
1	LAN3/LINK100#
2	LAN4/LINK100#
3	LAN3/LINK1000#
4	LAN4/LINK1000#
5	LAN3/ACT#
6	LAN4/ACT#
7	+3V
8	+3V

J5 Pin Out :

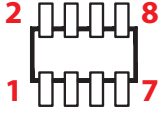
	
Pin Number	LAN PORT/Function
1	LAN5/LINK100#
2	LAN6/LINK100#
3	LAN5/LINK1000#
4	LAN6/LINK1000#
5	LAN5/ACT#
6	LAN6/ACT#
7	+3V
8	+3V

2.4.15 M.2 KEY E : USB, PCIe2 support

M.2 key E connector is suitable for applications that use wireless connectivity including Wi-Fi, Bluetooth, NFC or GNSS. Module card types include 1630, 2230.

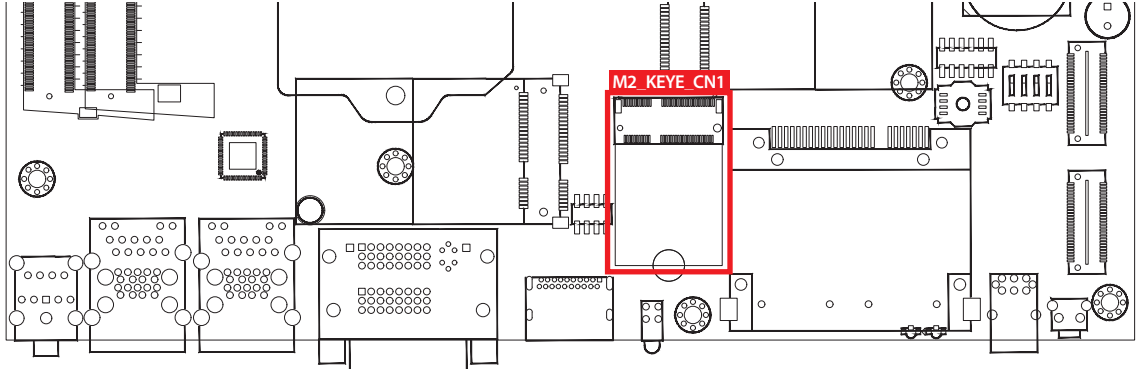

Pin No.	Definition	Pin No.	Definition
74	3.3V	75	GND
72	3.3V	73	RESERVED/REFCLKn1
70	NC	71	RESERVED/REFCLKp1
68	NC	69	GND
66	NC	67	RESERVED/PETn1
64	NC	65	RESERVED/PETp1
62	ALERT# (O)(0/3.3V)	63	GND
60	12C_CLK (I)(0/3.3V)	61	RESERVED/PERn1
58	12C_DATA (I/O)(0/3.3V)	59	RESERVED/PERp1
56	NC	57	GND
54	NC	55	PEWAKE0# (I/O) (0/3.3V)
52	PERST0# (I)(0/3.3V)	53	CLKREQ0# (I/O) (0/3.3V)
50	NC	51	GND
48	NC	49	REFCLKn0
46	NC	47	REFCLKp0
44	NC	45	GND
42	NC	43	PETn0
40	NC	41	PETp0
38	NC	39	GND
36	NC	37	PERn0
34	NC	35	PERp0
32	NC	33	GND
	Module Key		Module Key
	Module Key		Module Key
	Module Key		Module Key
	Module Key		Module Key

Pin No.	Definition	Pin No.	Definition
22	NC	23	NC
20	NC	21	NC
18	GND	19	NC
16	NC	17	NC
14	NC	15	NC
12	NC	13	NC
10	NC	11	NC
8	NC	9	NC
6	LED1# (O)(od)	7	GND
4	3.3V	5	USB_D-
2	3.3V	3	USB_D+
		1	GND

2.4.16 M.2 KEY M : PCIe x4/SATA Support

M.2 key M connector is suitable for applications that use Host I/Fs supported by either PCIe or SATA, or Solid State Storage Devices (SSD). Module card types include 2242, 2260, 2280.

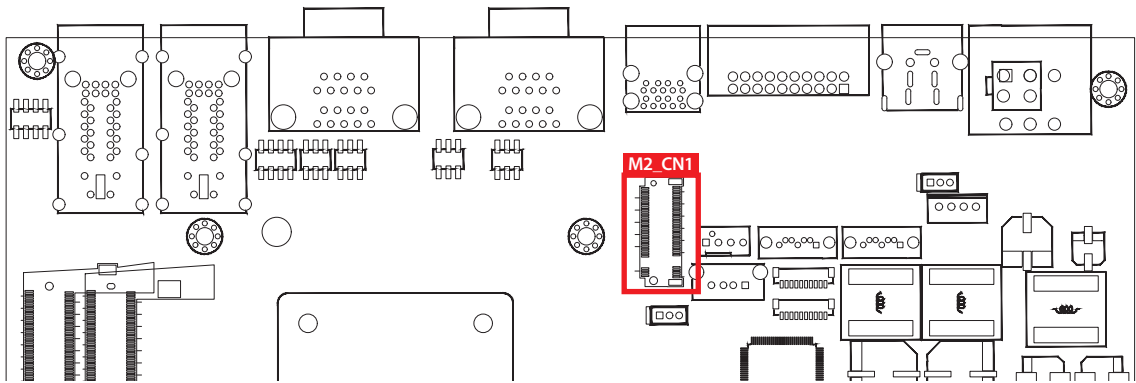

Pin No.	Definition	Pin No.	Definition
74	3.3V	75	GND
72	3.3V	73	GND
70	3.3V	71	GND
68	SCUSCLK (3.2KHz)(O) (0/3.3V)	69	PEDET (NC-PCIe/GND- SATA)
	Connector Key	67	N/C
	Connector Key		Connector Key
	Connector Key		Connector Key
	Connector Key		Connector Key
58	N/C		Connector Key

Pin No.	Definition	Pin No.	Definition
56	N/C	57	GND
54	PEWAKE# (I/O)(O) (0/3.3V) or N/C	55	REFCLKp
52	CLKREQ# (I/O)(O)(0/3.3V) or N/C	53	REFCLKn
50	PERST# (I/O)(O)(0/3.3V) or N/C	51	GND
48	N/C	49	PETp0/SATA-A+
46	N/C	47	PETn0/SATA-A-
44	N/C	45	GND
42	N/C	43	PERp0/SATA-B-
40	N/C	41	PERp0/SATA-B+
38	DEVSLP (O)	39	GND
36	N/C	37	PETp1
34	N/C	35	PETn1
32	N/C	33	GND
30	N/C	31	PERp1
28	N/C	29	PERn1
26	N/C	27	GND
24	N/C	25	PETp2
22	N/C	23	PETn2
20	N/C	21	GND
18	3.3V	19	PERp2
16	3.3V	17	PERn2
14	3.3V	15	GND
12	3.3V	13	PETp3
10	DAS/DDS# (I/O)/LED1# (I) (0/3.3V)	11	PETn3
8	N/C	9	GND
6	N/C	7	PERp3
4	3.3V	5	PERn3
2	3.3V	3	GND
		1	GND

2.5 Main Board Jumper Settings

2.5.1 Board top view of the system main board with jumper and deep switch

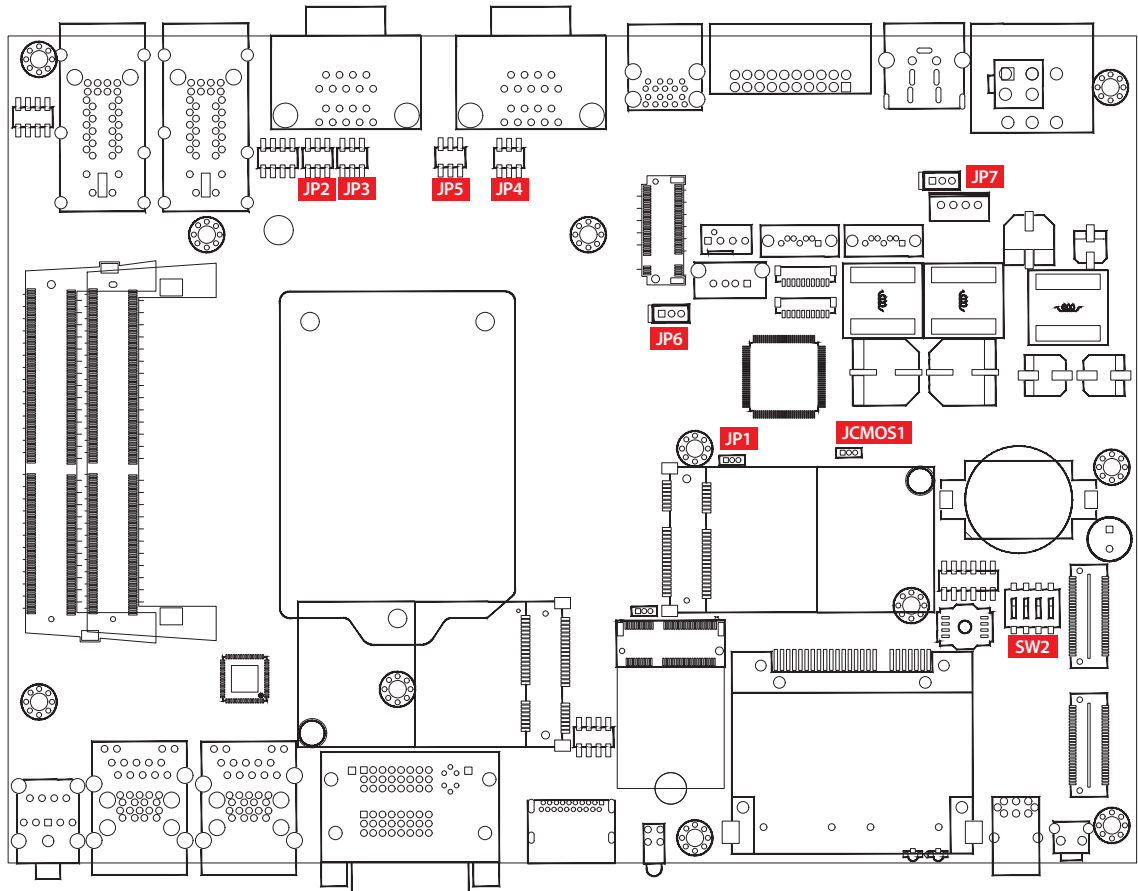

The figure above is the top view of the system main board. It shows the location of the jumpers and the switches.

You may configure your card to match the needs of your application by setting jumpers. A jumper is a metal bridge used to close an electric circuit. It consists of two metal pins and a small metal clip (often protected by a plastic cover) that slides over the pins to connect them. To "close" a jumper, you connect the pins with the clip. To "open" a jumper, you remove the clip. Sometimes a jumper will have three pins, labeled 1, 2 and 3. In this case you would connect either pins 1 and 2, or 2 and 3.

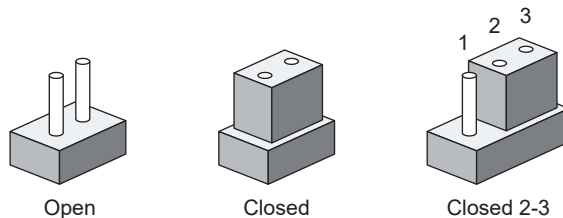

You may configure your card to match the needs of your application by DIP switch. As below show the deep switch on and off.

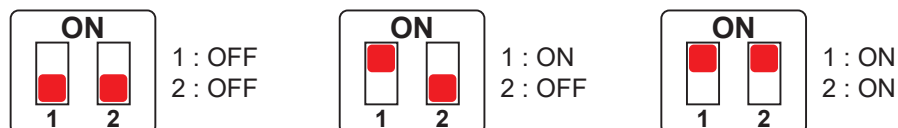

2.5.2 JP6 : USB Wake Up

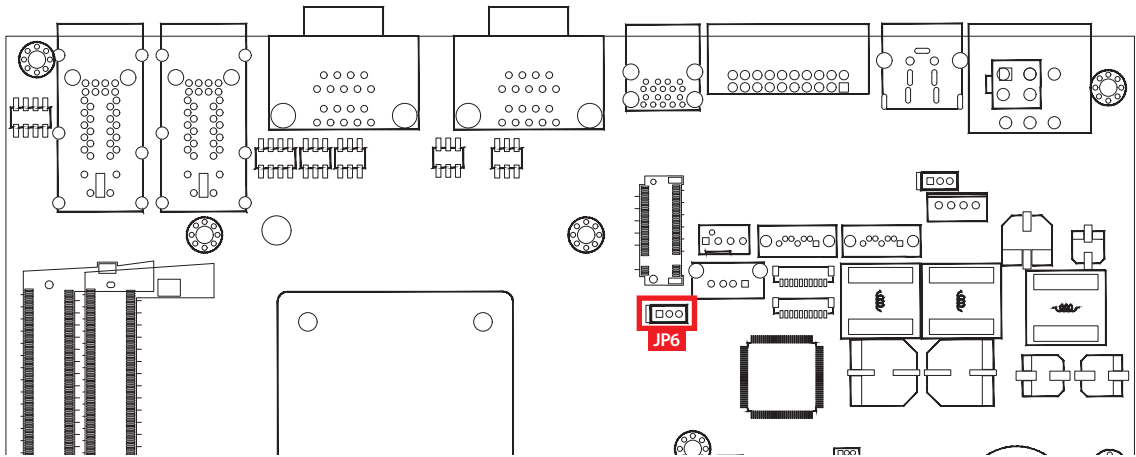

Jumper	Setting	Function
JP6	2:3	Non Wake Up support
JP6	1:2	Supported Wake Up (Default)

2.5.3 JP2, JP3, JP4, JP5 : COM Port RI pin Select

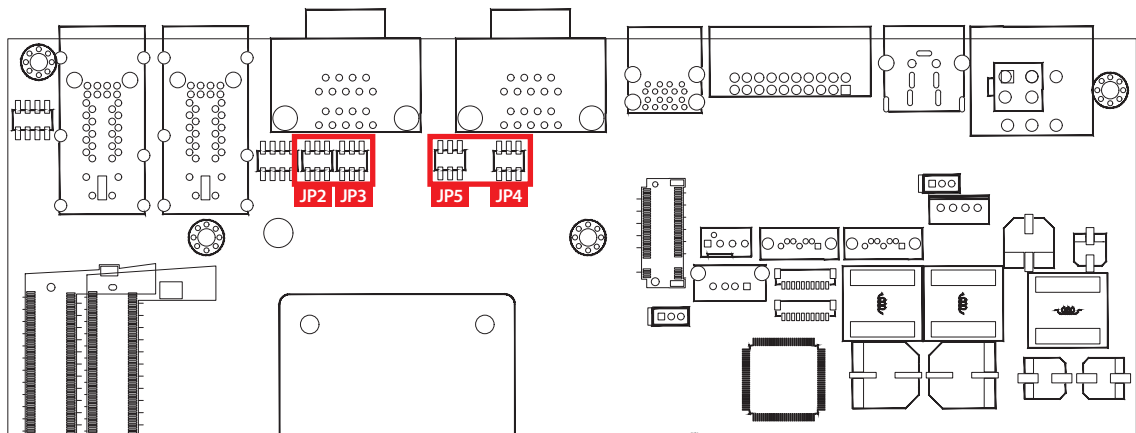

Pin Header	Pin No.	Description
COM1 JP2	1 - 2	+5V (1A max.)
	3 - 4	+12V (0.5A max.)
	5 - 6	RI (Default)

Pin Header	Pin No.	Description
COM2 JP3	1 - 2	+5V (1A max.)
	3 - 4	+12V (0.5A max.)
	5 - 6	RI (Default)

Pin Header	Pin No.	Description
COM3 JP4	1 - 2	+5V (1A max.)
	3 - 4	+12V (0.5A max.)
	5 - 6	RI (Default)

Pin Header	Pin No.	Description
COM4 JP5	1 - 2	+5V (1A max.)
	3 - 4	+12V (0.5A max.)
	5 - 6	RI (Default)

2.5.4 JP7 : PoE Power ON Select

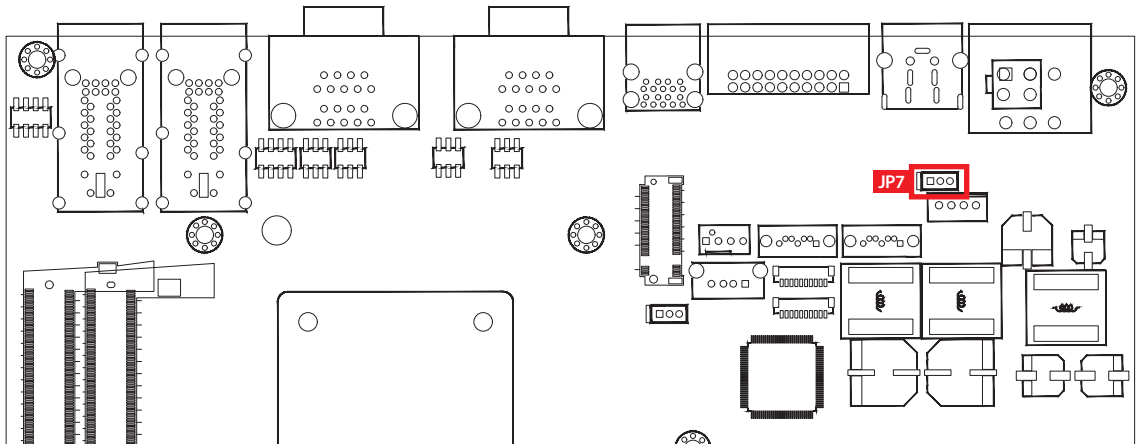

Jumper	Setting	Function
JP7	1:2	PoE power on at standby power ready
JP7	2:3	PoE power on after system power on (Default)
JP7	No Jumper	Disable PoE power

2.5.5 JCMOS1, JP1 : CMOS & ME Flash

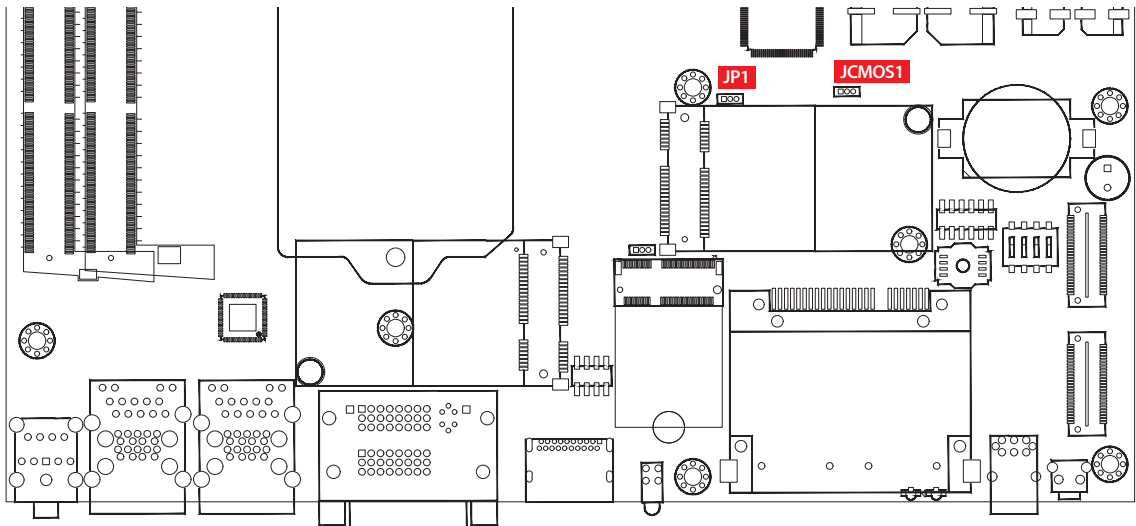

Jumper	Setting	Function
JCMOS1	1:2	*Normal (Default)
JCMOS1	2:3	Clear CMOS

Jumper	Setting	Function
JP1	1:2	Enable security measures defined in the Flash Descriptor. (Default)
JP1	2:3	Disable Flash Descriptor Security (Flash ME)

2.6 Ignition Control





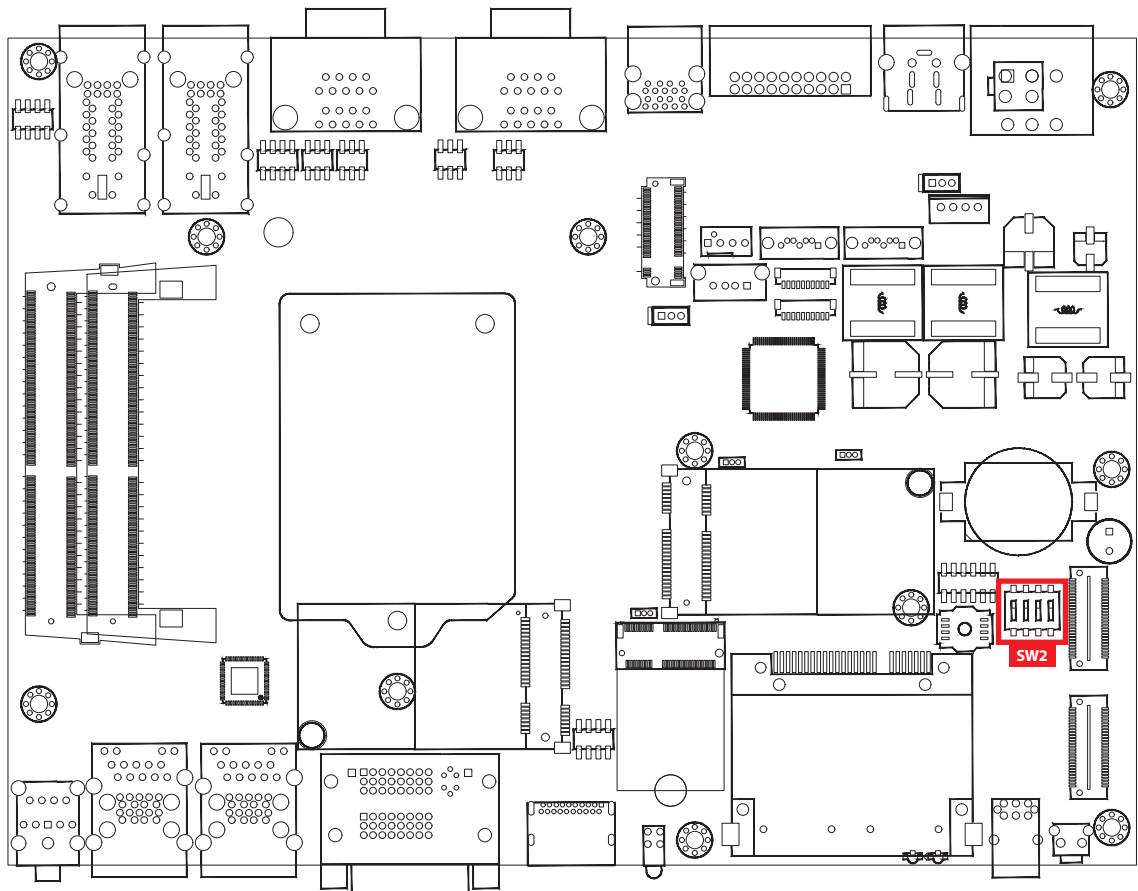

Echo 246F series provide ignition power control featuring for in-vehicle applications. The built-in MCU monitors the ignition signal and turns on/off the system according to pre-defined on/off delay periods.

2.6.1 Adjust Ignition Control Modes

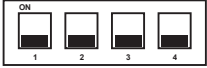
Echo 246F series provide 16 modes of different power on/off delay periods adjustable via SW5 switch. The default dip switch is set to 0 in ATX/AT power mode.

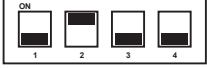
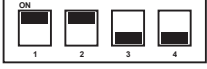
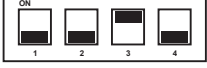
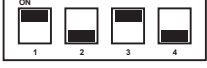
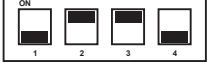
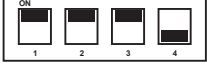

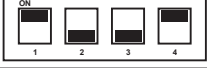
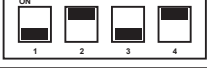
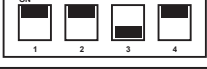
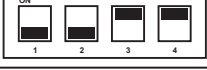
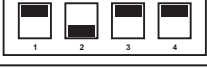
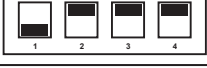
The modes are listed in below table :

Deep Switch Position	Power on delay	Power off delay	Switch Position
0	ATX/AT mode (Default)		
1	No delay	No delay	
2	No delay	5 seconds	
3	No delay	10 seconds	
4	No delay	20 seconds	
5	5 seconds	30 seconds	
6	5 seconds	60 seconds	
7	5 seconds	90 seconds	
8	5 seconds	30 minutes	
9	5 seconds	1 hour	
A	10 seconds	2 hours	
B	10 seconds	4 hours	
C	10 seconds	6 hours	
D	10 seconds	8 hours	
E	10 seconds	12 hours	
F	10 seconds	24 hours	

2.6.2 Ignition Control Wiring

To activate ignition control, you need to provide IGN signal via the 3-pin pluggable terminal block in the back panel. Please find below the general wiring configuration.

Pin No.	Definition
1	Ignition (IGN)
2	SW+
3	SW-



For testing purpose, you can refer to the picture below to simulate ignition signal input controlled by a latching switch.

Note :

1. DC power source and IGN share the same ground.
2. Echo 246F supports 6V to 36V wide range DC power input in ATX/AT mode. In Ignition mode, the input voltage is fixed to 12V/24V for car battery scenario.
3. For proper ignition control, the power button setting should be in "Power Down" mode.

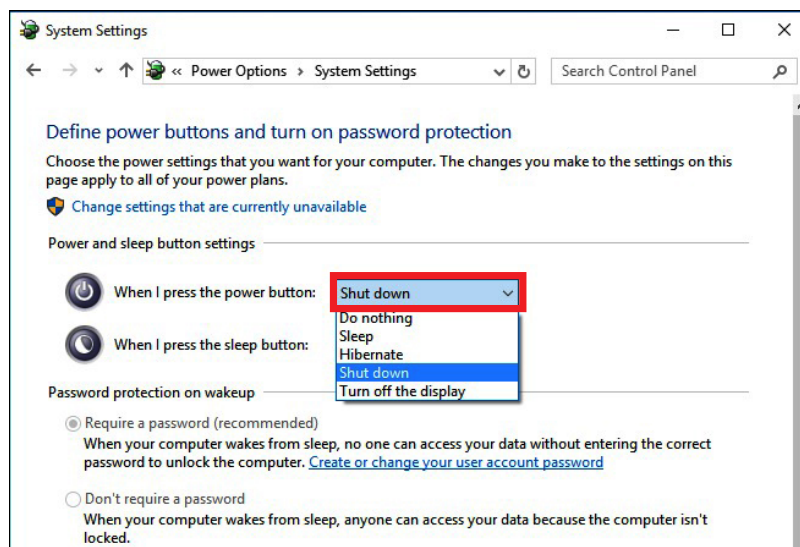

In Windows, for example, you need to set "When I press the power button" to "Shut down."

3

SYSTEM SETUP

3.1 How to Open Your Echo 246F

3.1.1 Echo 246F-G9R/Echo 246F-PoER/Echo 246F-FOR/ Echo 246F-G4R/Echo 246FR/Echo 246F-10GJR/Echo 246F-10GSR

Step 1 Turn Echo 246F bottom side up and remove 6pcs HEX#6-32 screws from the front panel.

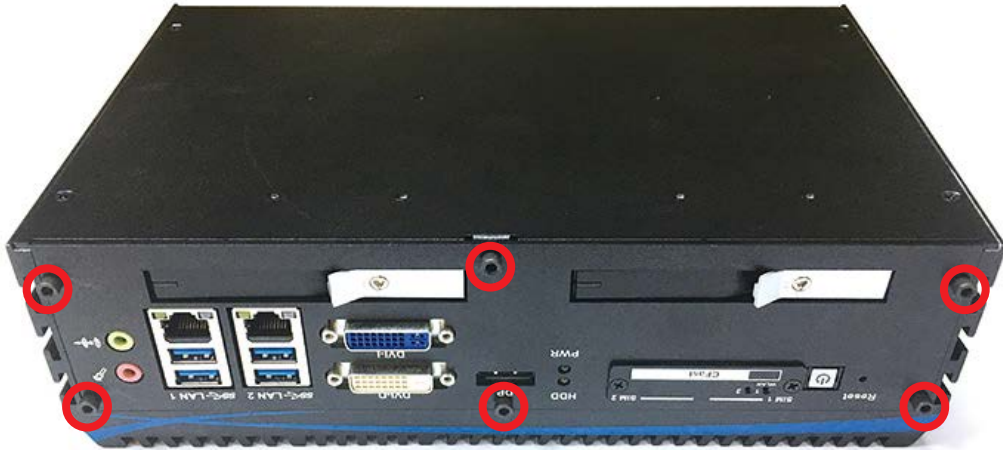

Step 2 Remove front panel.



Step 3 Turn over Echo 246F to face the rear side.



Step 4 Remove 5pcs HEX#6-32 screws (circled in red) from the rear side and 4pcs PHILLIPS#6-32 screws (circled in yellow) from the bottom side.



Step 5 Remove rear panel.



Step 6 Remove the SATA cable and SATA power cables.

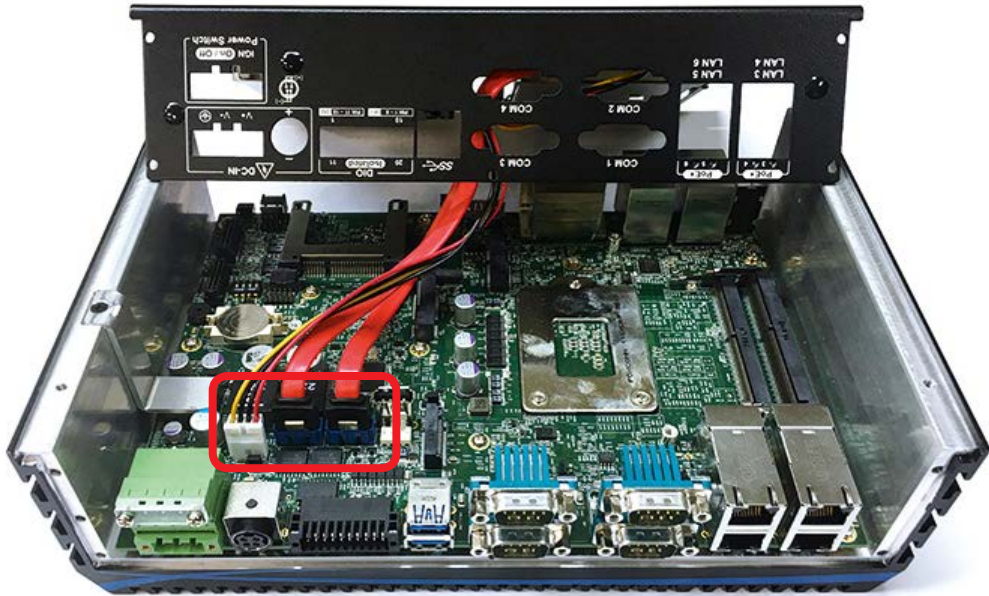

Step 7 Finished.



3.1.2 Echo 246F-G9/Echo 246F-PoE/Echo 246FO/ Echo 246F-G4/Echo 246F/Echo 246F-10GJ/Echo 246F-10GS

Step 1 Turn Echo 246F bottom side up and remove 6pcs HEX#6-32 screws from the front panel.



Step 2 Remove front panel.



Step 3 Turn over Echo 246F to face the rear side.



Step 4 Remove 5pcs HEX#6-32 screws (circled in red) from the rear side.



Step 5 Remove 1pcs PHILLIPS M3 screw from SSD/HDD cover and then remove the cover.



Step 6 Remove 4pcs PHILLIPS#6-32 screws from the bottom side.



Step 7 Remove rear panel.



Step 8 Remove the SATA cable and SATA power cable.

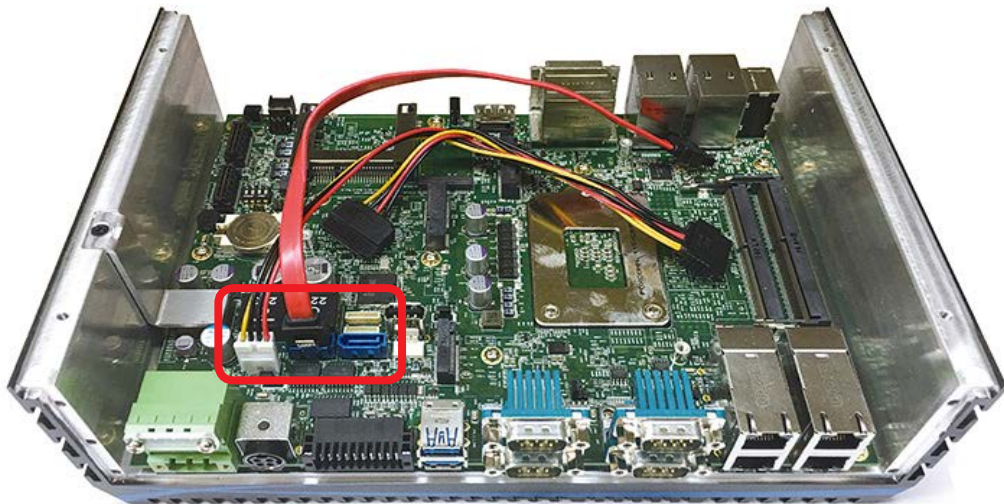

Step 9 Finished.



3.2 Installing CPU

3.2.1 Remove Main Board and Install CPU

Step 1 Remove 1pcs PHILLIPS#6-32 screw and chock bracket.

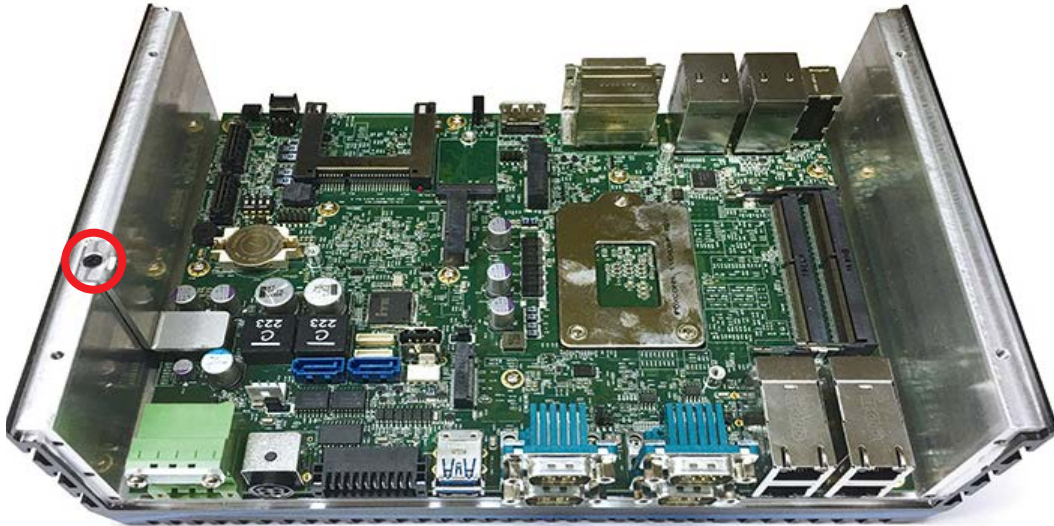

Step 2 Remove 11pcs PHILLIPS M3 screws.

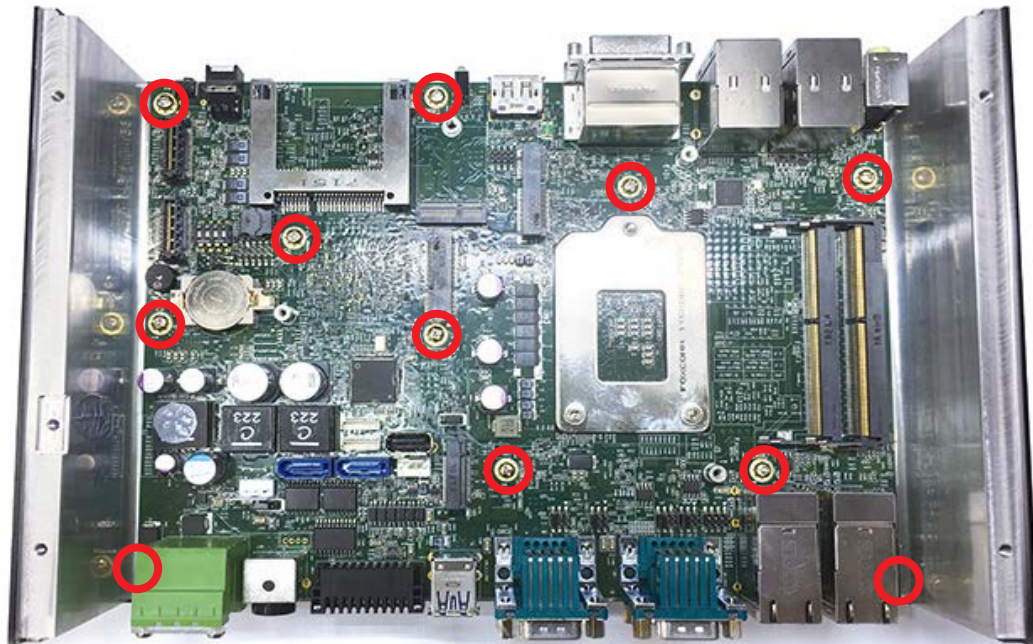

Step 3 Take out Main Board from the heat sink.

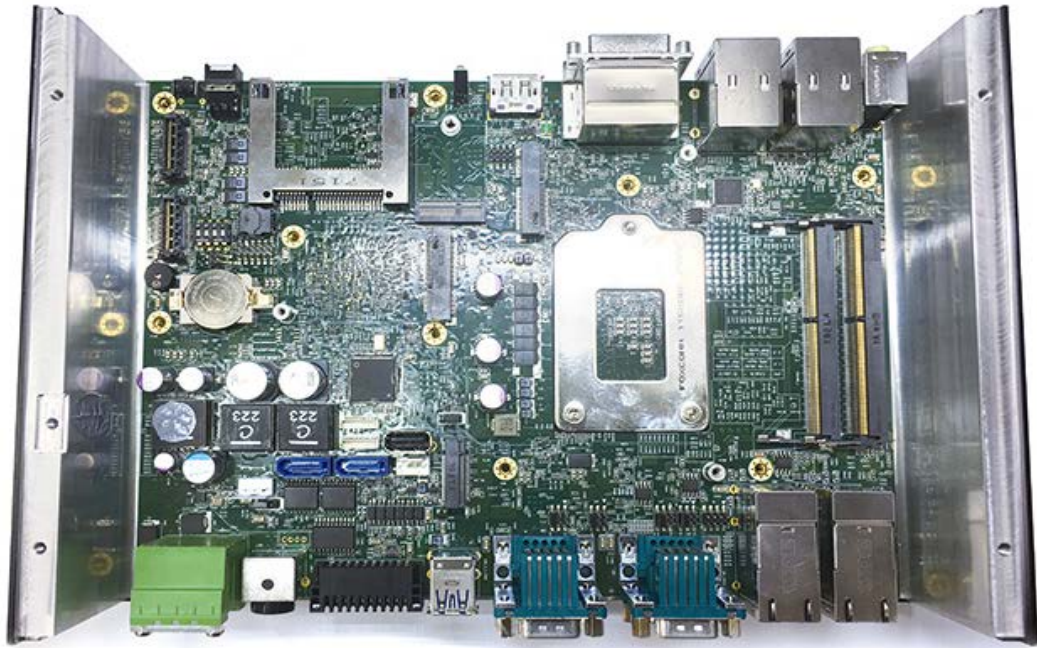

Step 4 Turn over the main board to make the CPU socket side up.

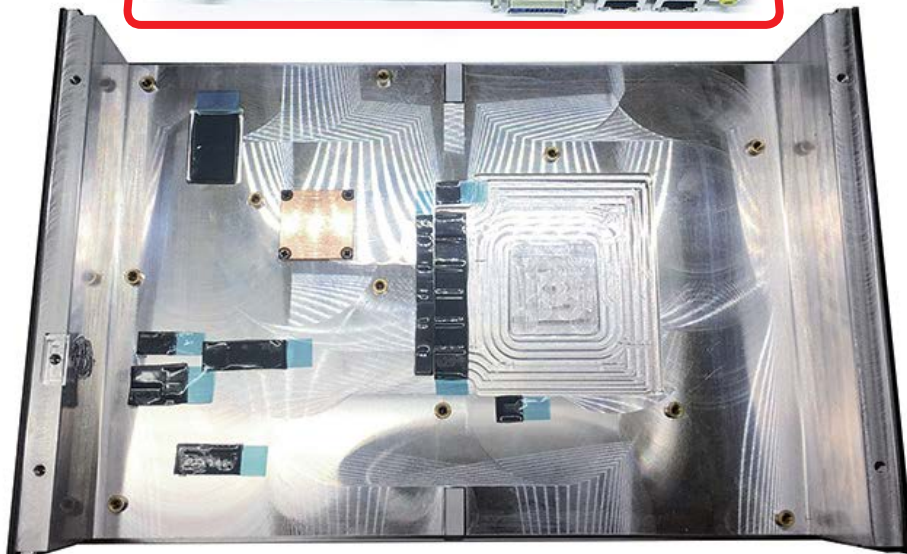
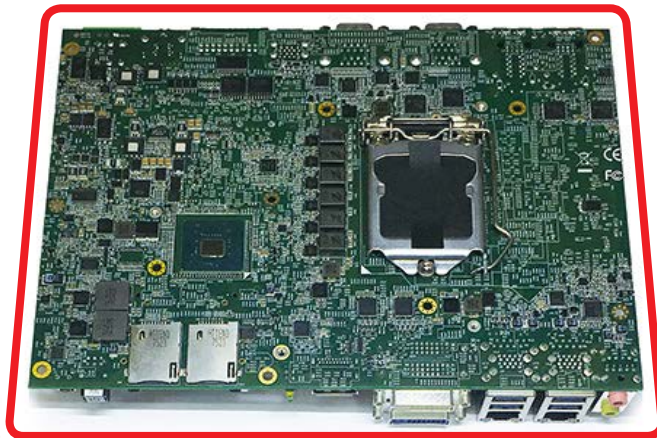

Step 5 Unlock the CPU socket.

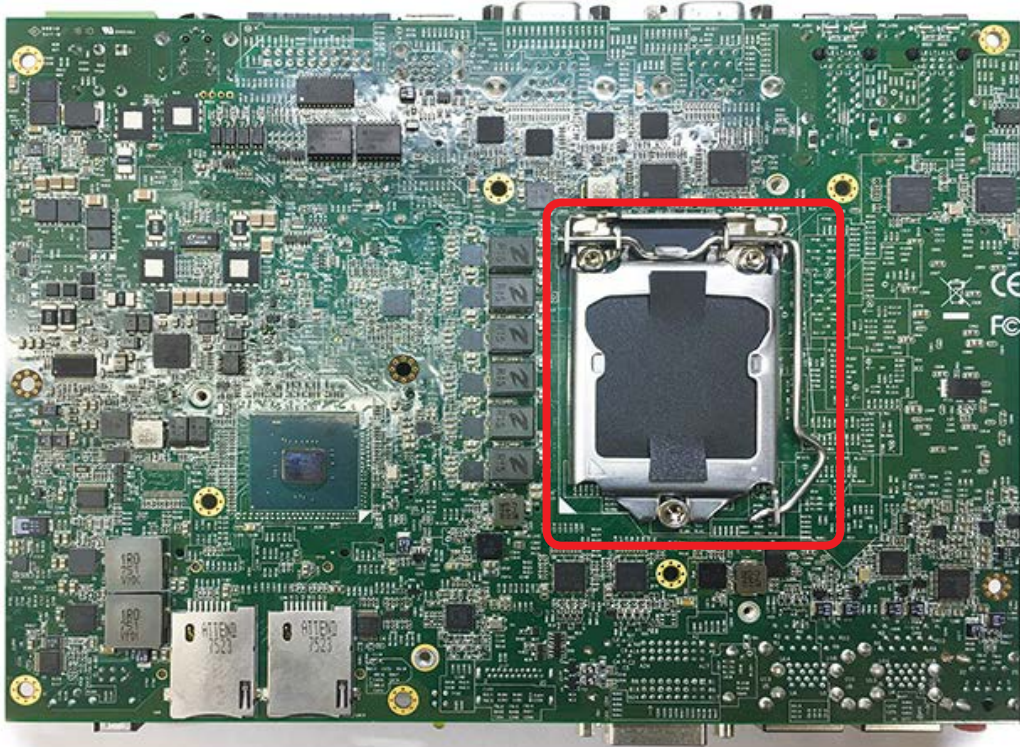

Step 6 Open the CPU socket cover.

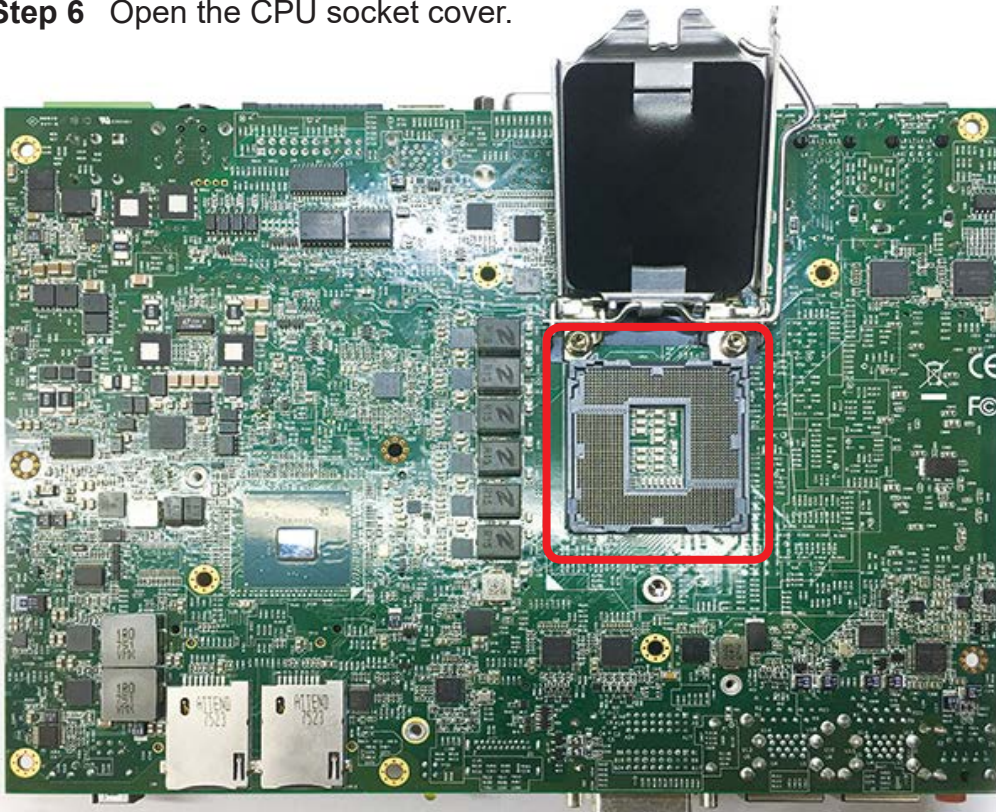

Step 7 Watch out the direction of CPU.

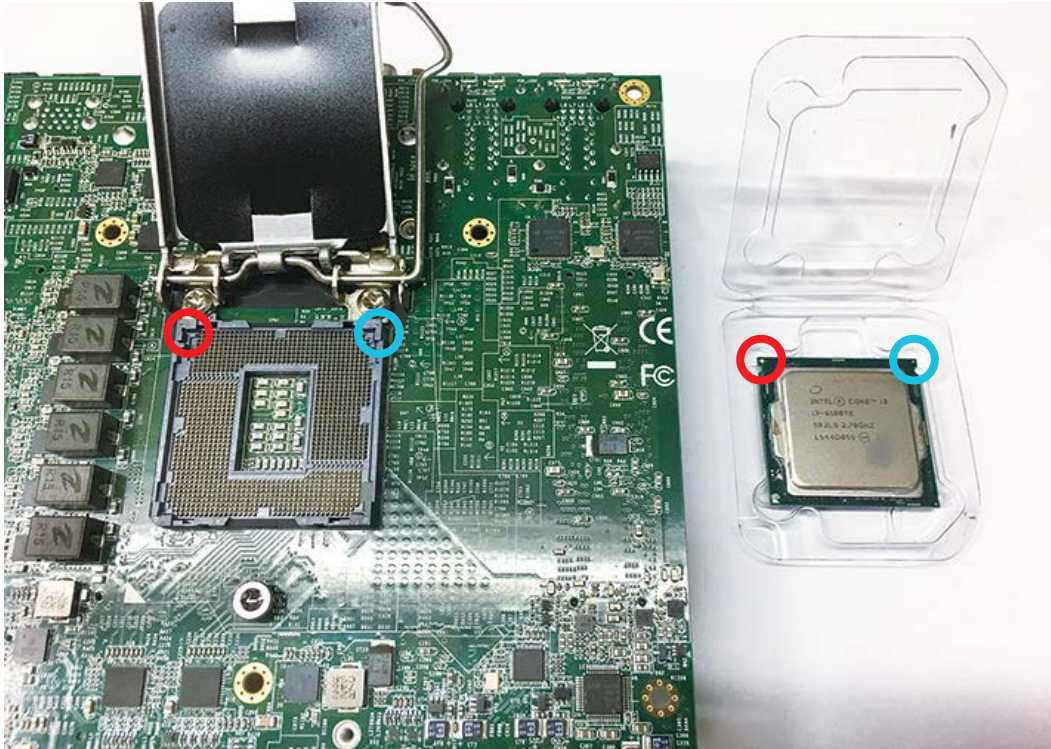

Step 8 Put CPU into the CPU socket.

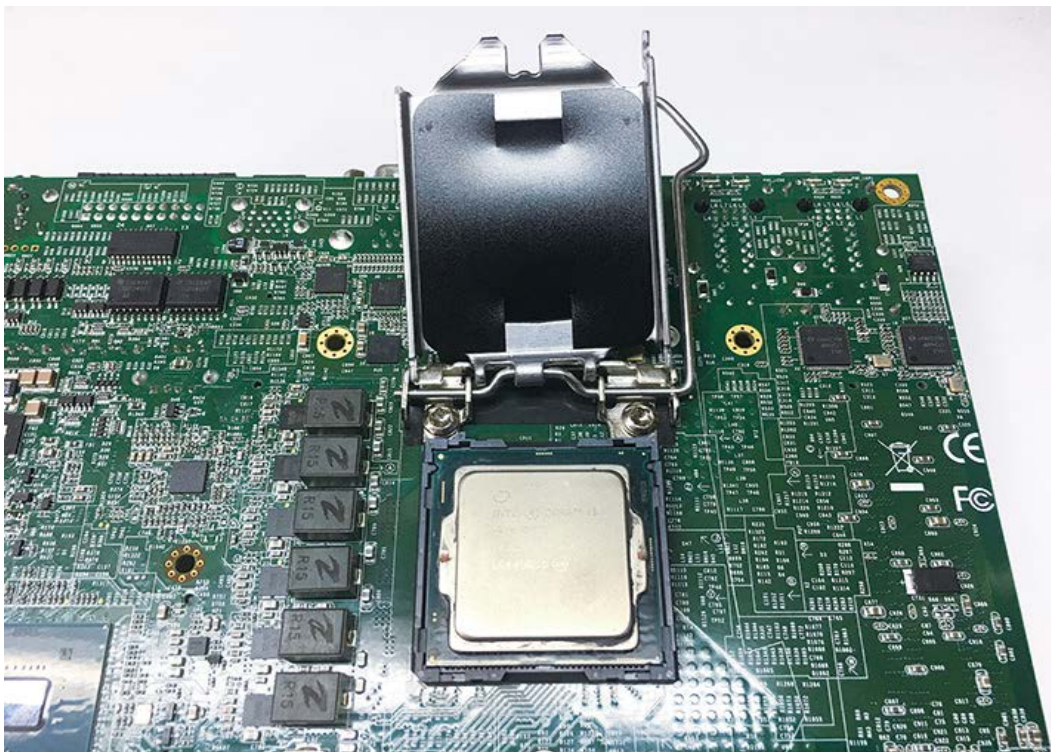

Step 9 Remove the mylar from CPU cover and lock the cover.



Step 10 Finished.



3.2.2 Remove Main Board with SUMIT and Install CPU

Step 1 Remove 1pcs PHILLIPS#6-32 screw and chock bracket.

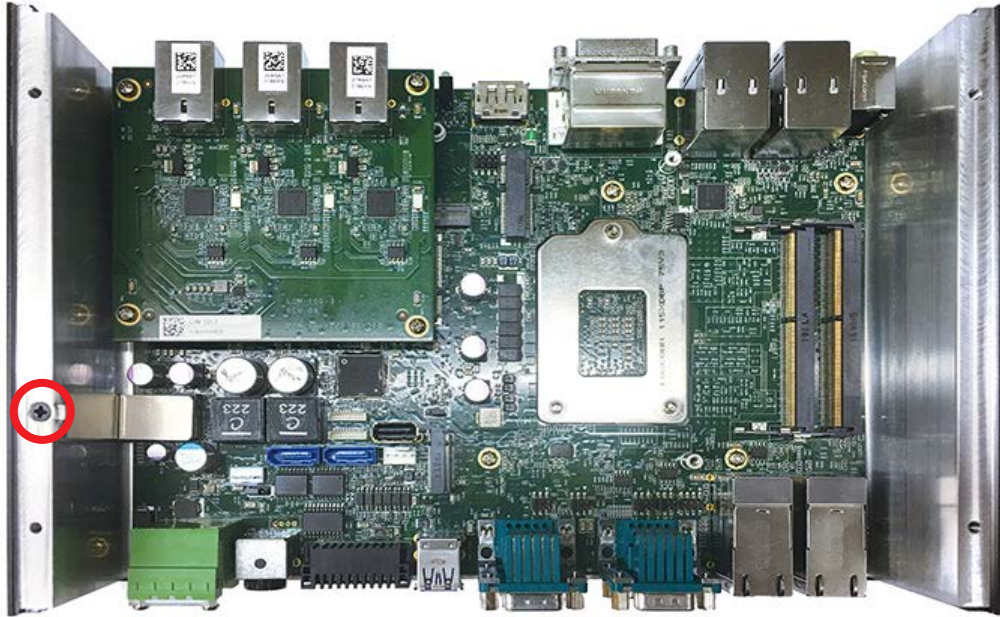

Step 2 Remove 4pcs PHILLIPS M3 screws.

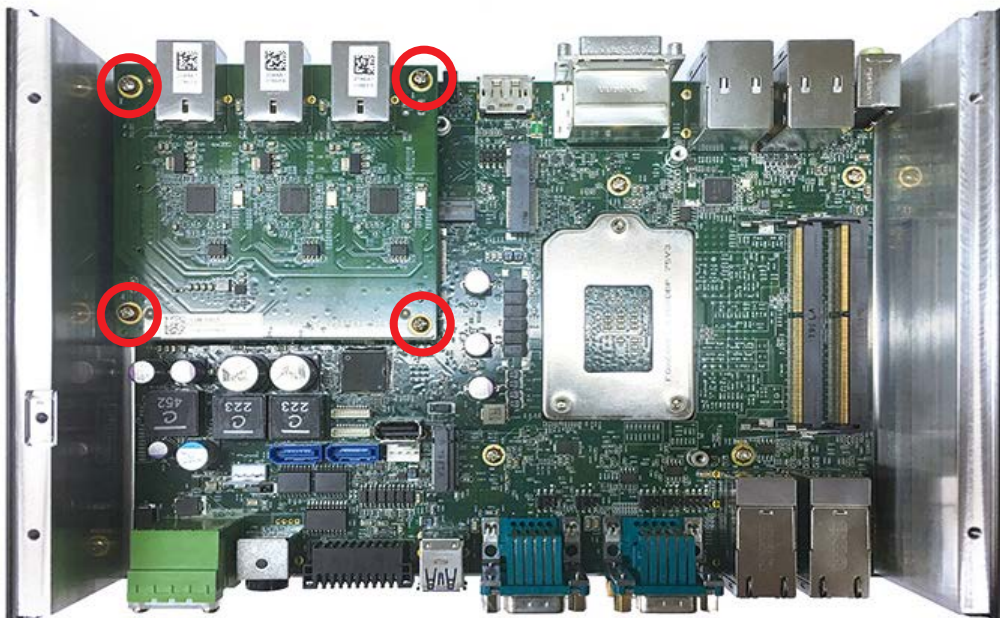

Step 3 Remove SUMIT card.

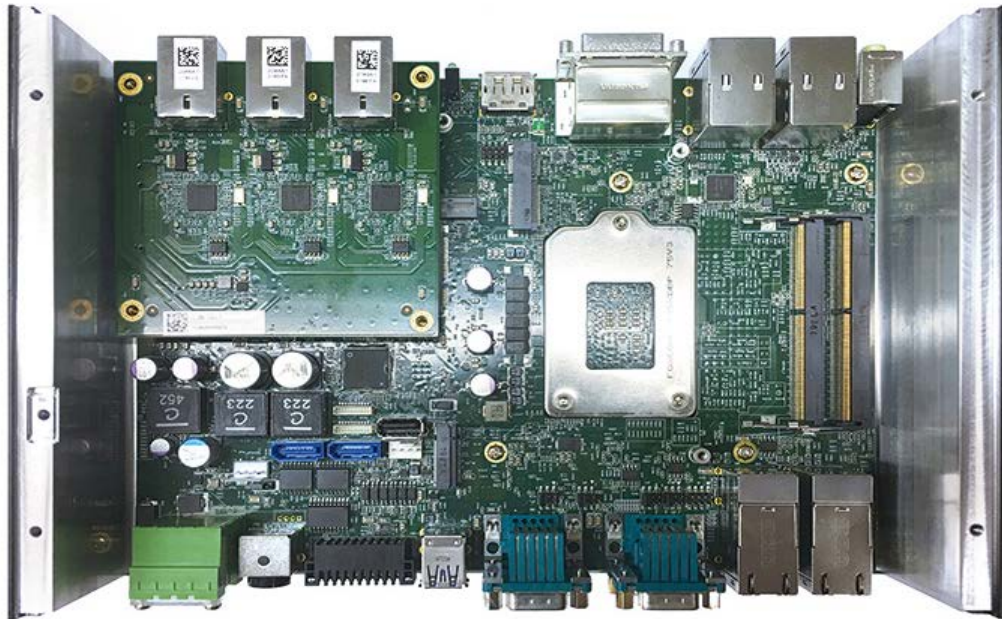

Step 4 Remove 4pcs stand off and 7pcs PHILLIPS M3 screws.

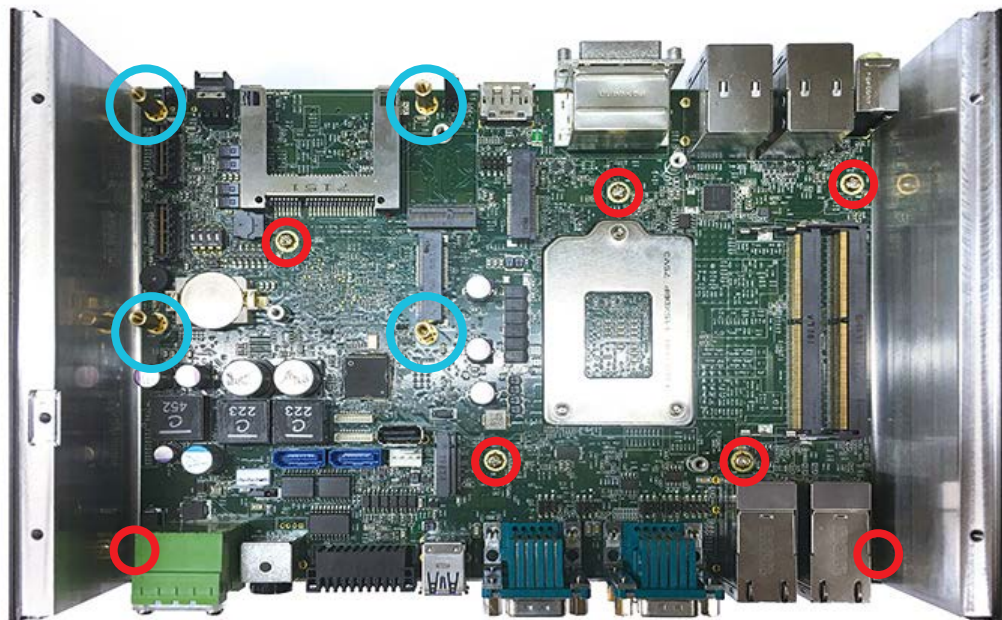

Step 5 Turn over the main board to make the CPU socket side up.



Step 6 Unlock CPU socket.

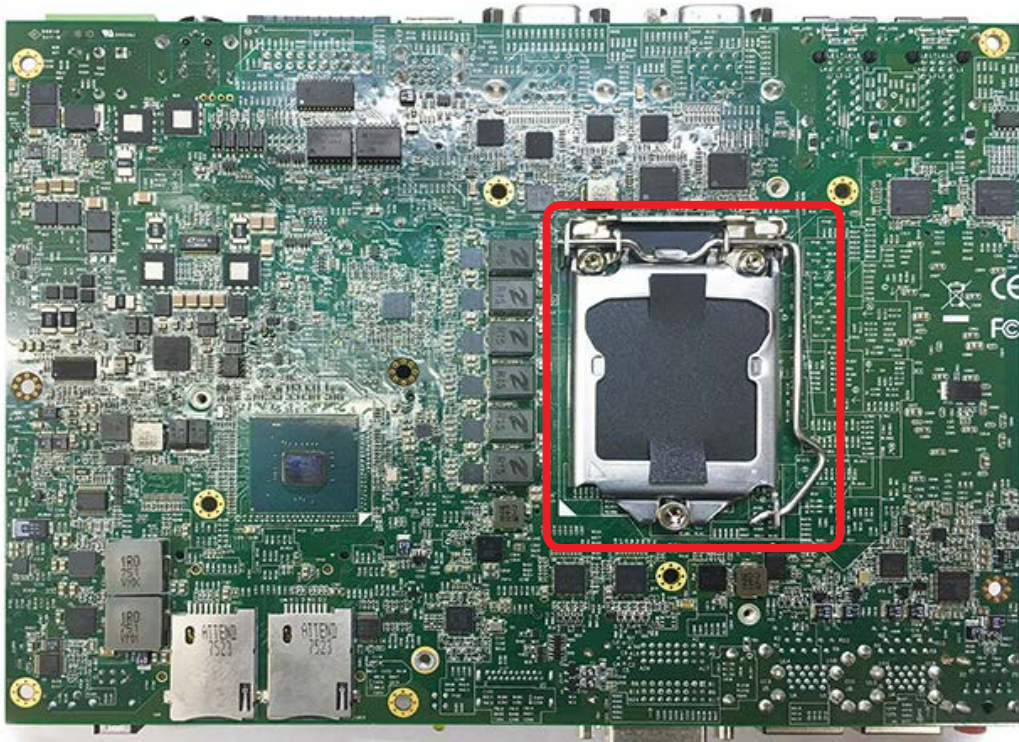

Step 7 Open the CPU socket cover.

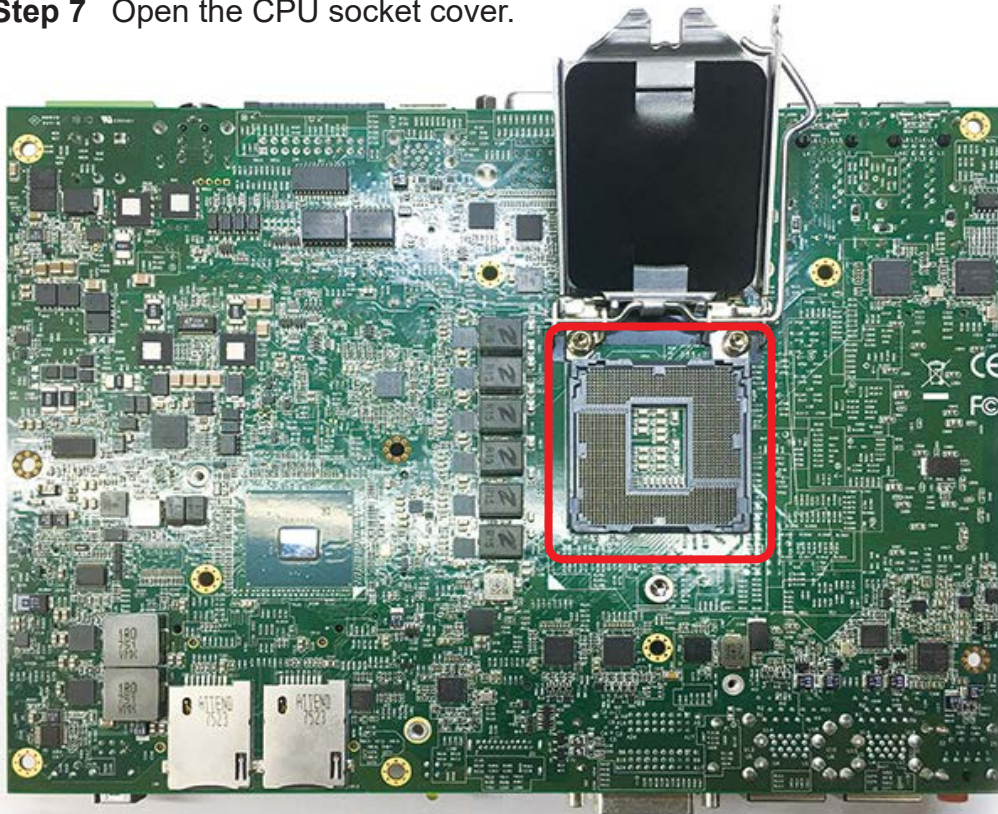

Step 8 Watch out the direction of CPU.

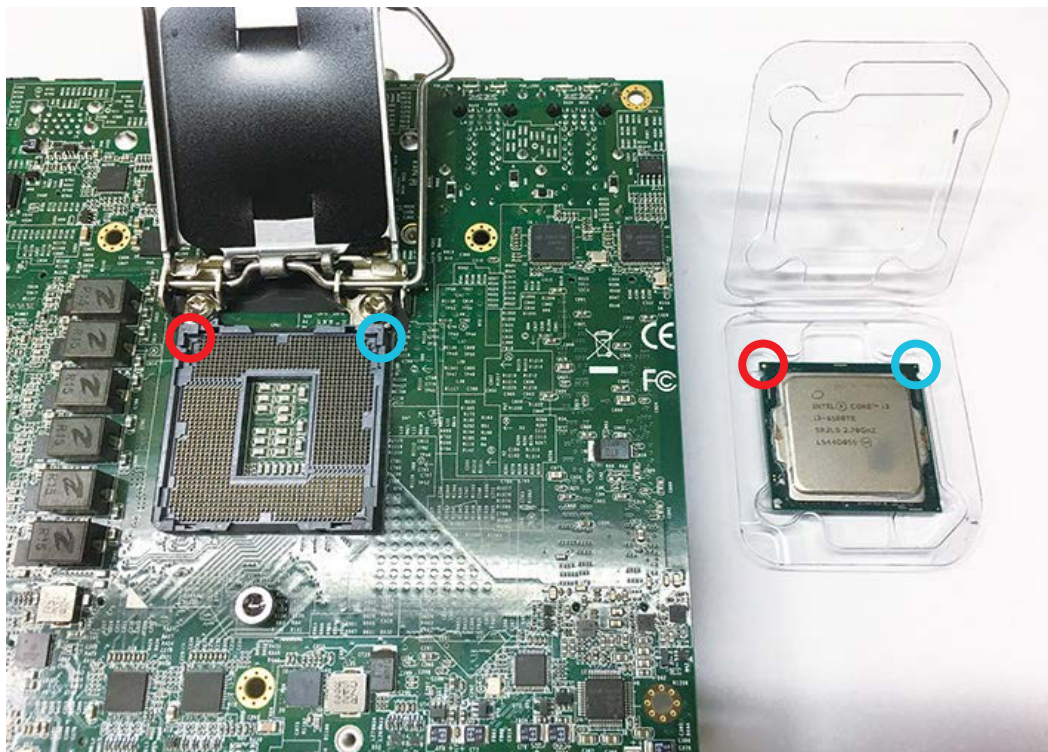

Step 9 Put CPU into the CPU socket.



Step 10 Remove the mylar from CPU cover and lock the cover.

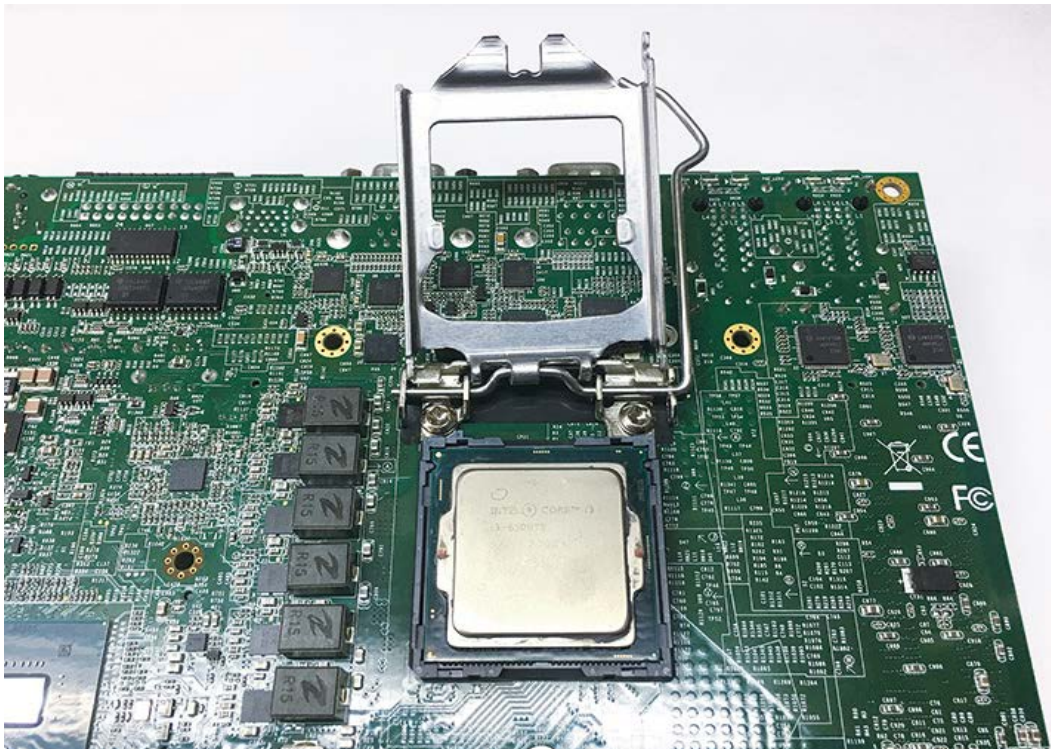

Step 11 Finished.



3.3 Installing DDR4 SO-DIMM Modules

Step 1 DDR4 SO-DIMM socket.

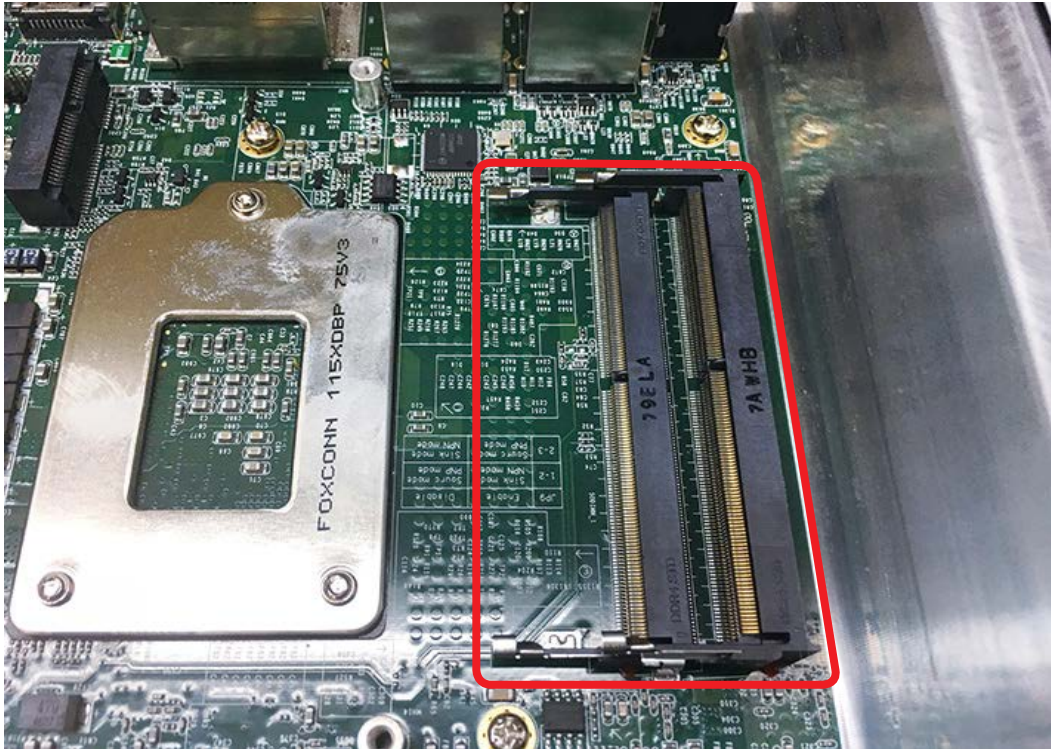

Step 2 Install DDR4 RAM module into SO-DIMM socket.



Step 3 Install DDR4 RAM module into SO-DIMM socket.



3.4 Installing Mini PCIe Card

Step 1 Mini PCIe socket.

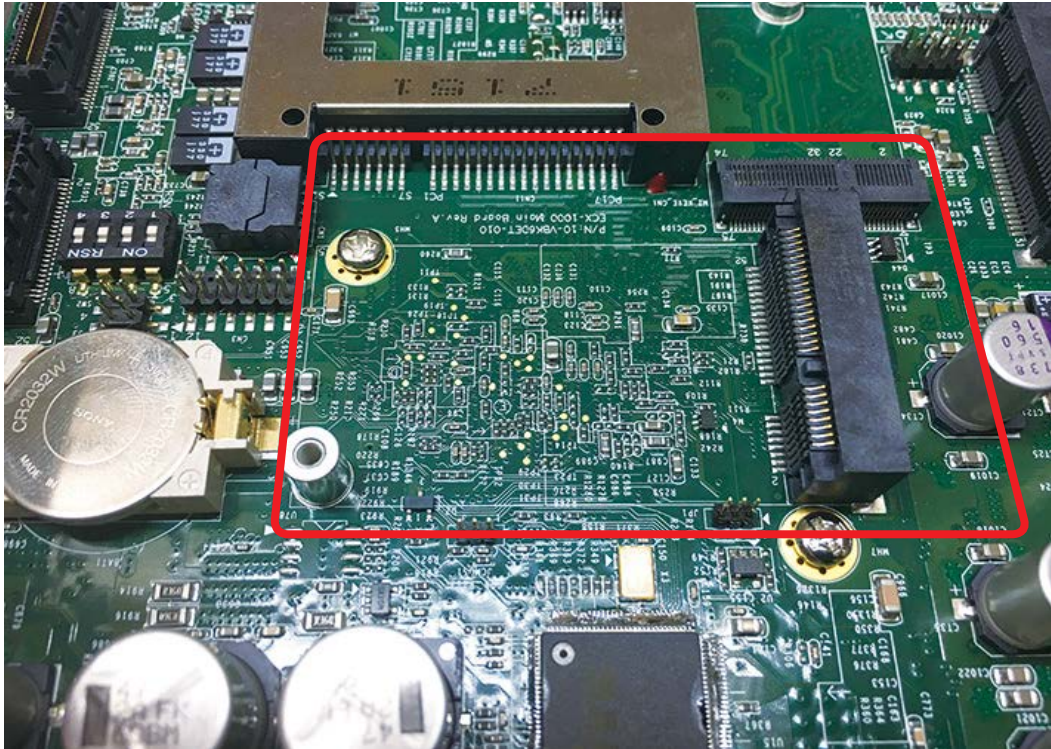

Step 2 Install Mini PCIe card into socket.



3.5 Installing Antenna Cable

Step 1 Check antenna cable and washer.



Step 2 Rear panel antenna hole.



Step 3 Install antenna cable.



Step 4 Fasten washer 1 and 2.



Step 5 Finished.



3.6 Installing CFast Card

Step 1 Remove 2pcs PHILLIPS M3 screws on CFast & SIM cover at front panel.



Step 2 Before installing CFast, make sure the system power is not working.

Step 3 Insert CFast card and push to lock.

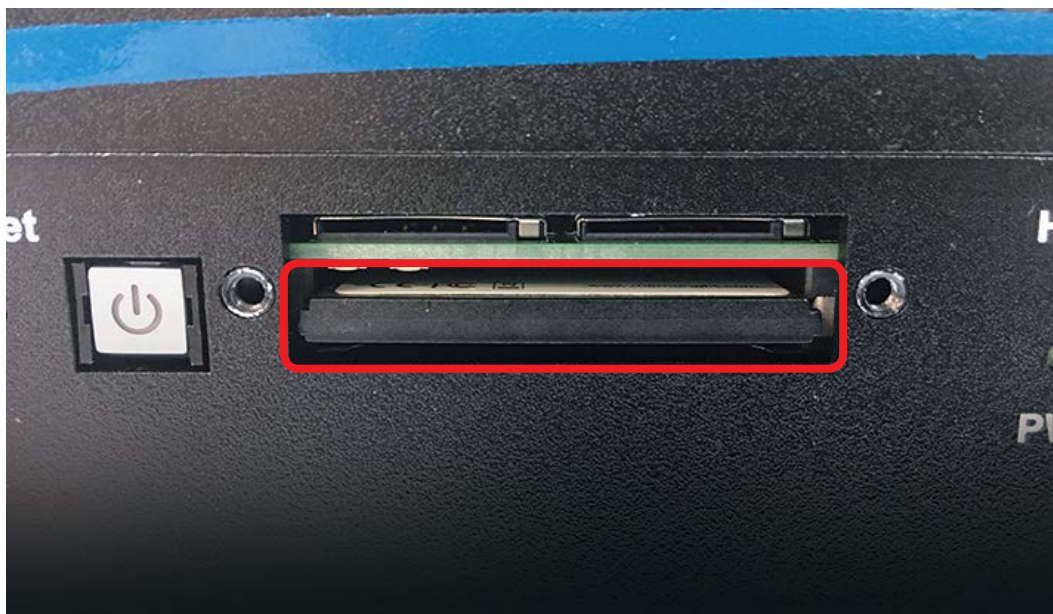

3.7 Installing SIM Card

Step 1 Remove 2pcs PHILLIPS M3 screws on CFast & SIM cover at front panel.

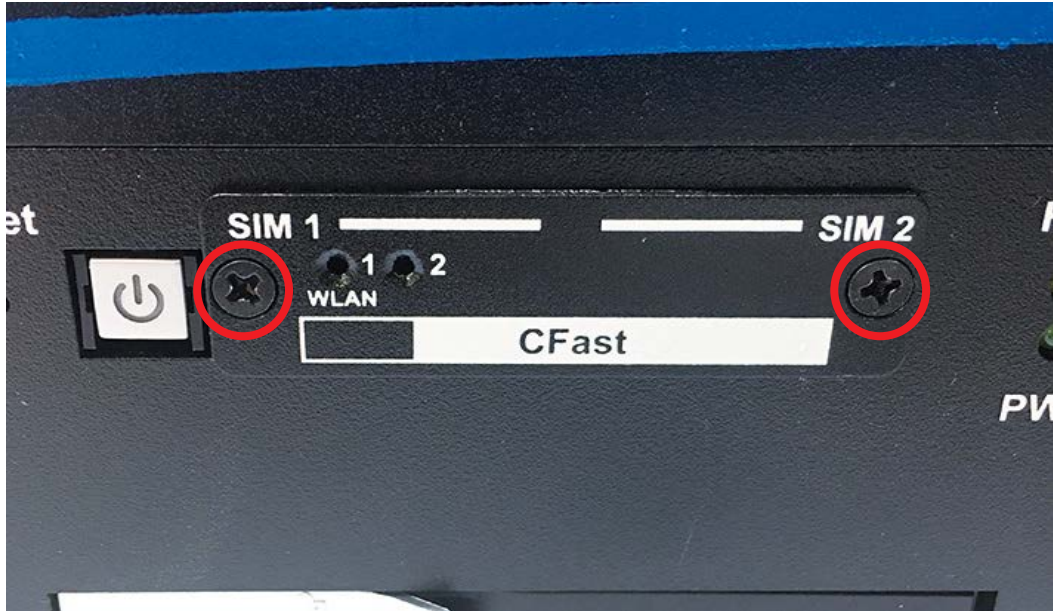

Step 2 Before install CFast, make sure the system power is not working.

Step 3 Insert SIM card and push to lock.



3.8 Installing SSD/HDD

3.8.1 Echo 246FR series

Step 1 Unlock SSD/HDD tray.

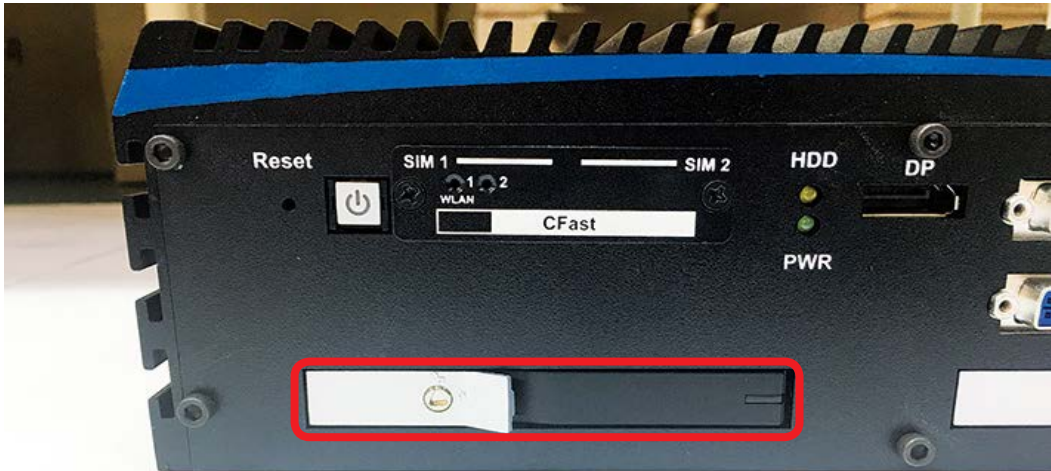

Step 2 Pull the trigger and open SSD/HDD tray.



Step 3 Install 2.5" SSD/HDD into the tray and then push back to close the tray.



Step 4 Lock the SSD/HDD tray with key.



3.8.2 Echo 246F series

Step 1 Remove 1pcs PHILLIPS M3 screw from SSD/HDD cover on the bottom.



Step 2 Remove SSD/HDD cover.

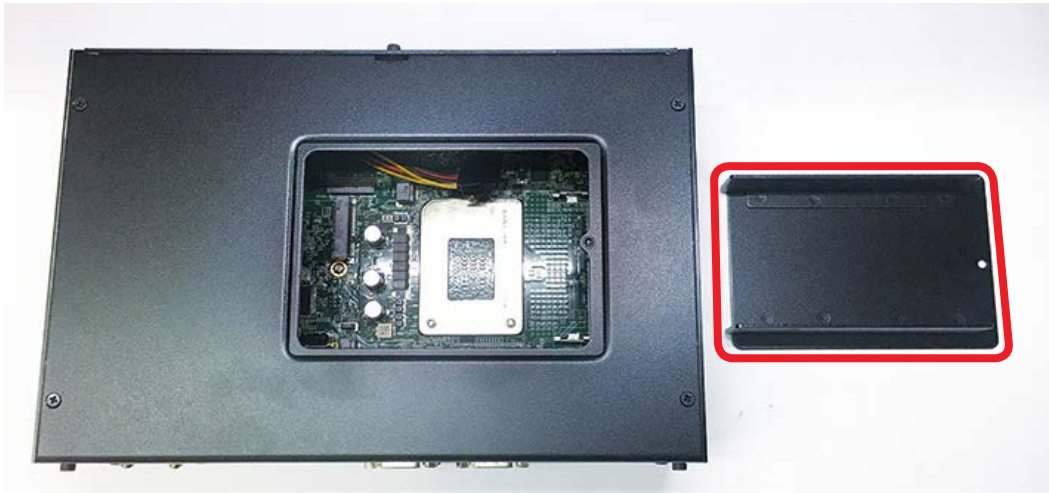

Step 3 Put SSD into SSD/HDD cover.



Step 4 Fasten PHILLPIS M3 screw. (one SSD/HDD with 4pcs PHILLPIS M3 screws)



Step 5 Connect SATA cable and SATA power cable to SSD/HDD.



Step 6 Finished.



3.9 Installing M.2

Step 1 M.2 socket.

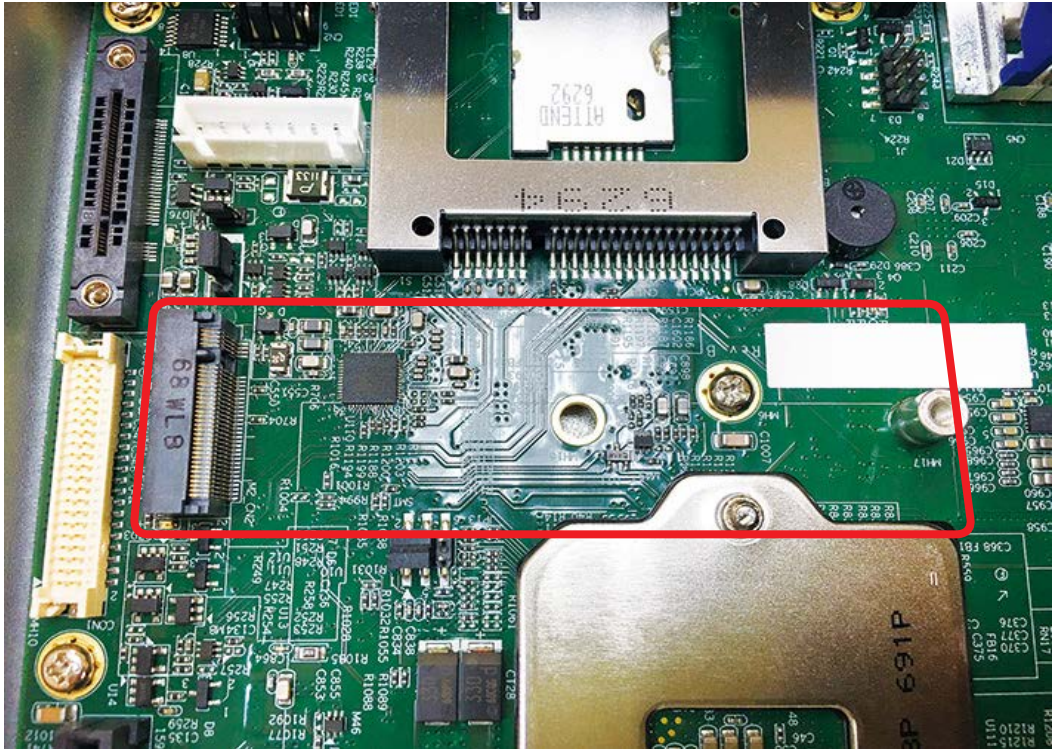

Step 2 Install M.2 into socket and fasten 1pcs PHILLIPS M3 screw.



3.10 Mounting Your Echo 246F

3.10.1 Wall mount

Fasten 6pcs PHILLIPS#10-32 screws.

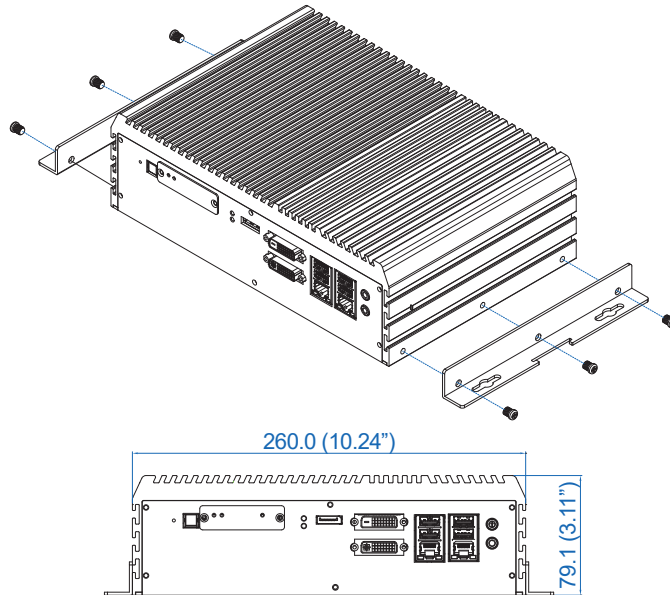

3.10.2 VESA mount

Fasten 6pcs PHILLIPS#10-32 screws.

VESA 75 x 75/100 x 100 mm

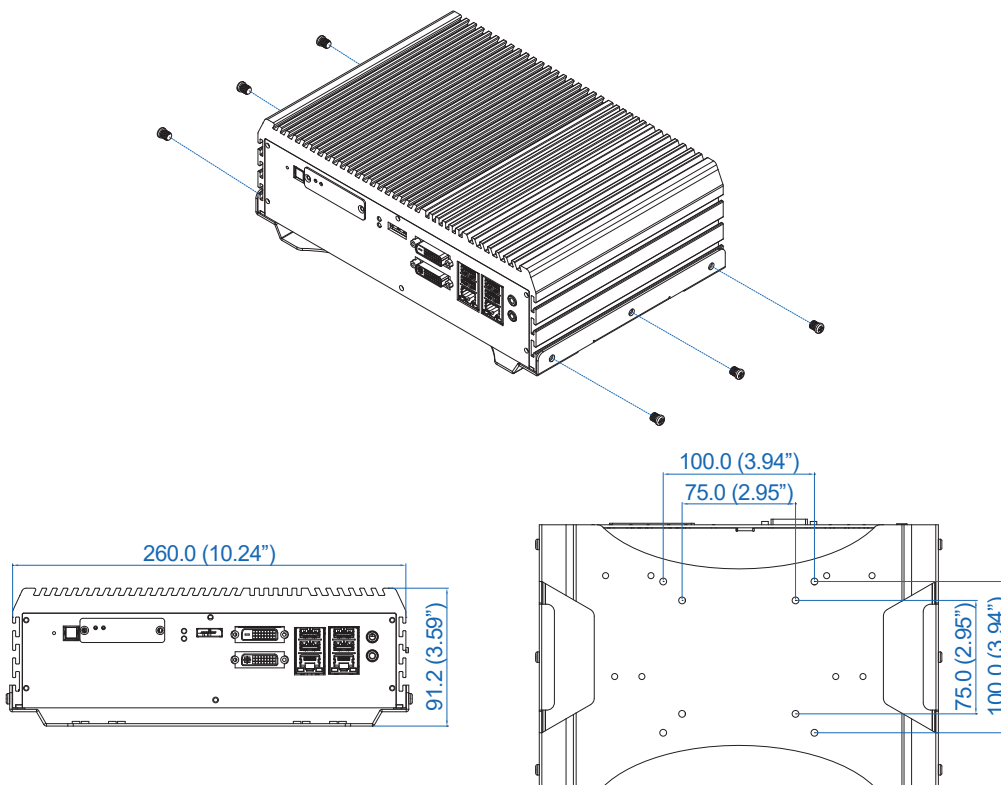

3.10.3 Din Rail Kit

Fasten 6pcs PHILLIPS#10-32 screws.

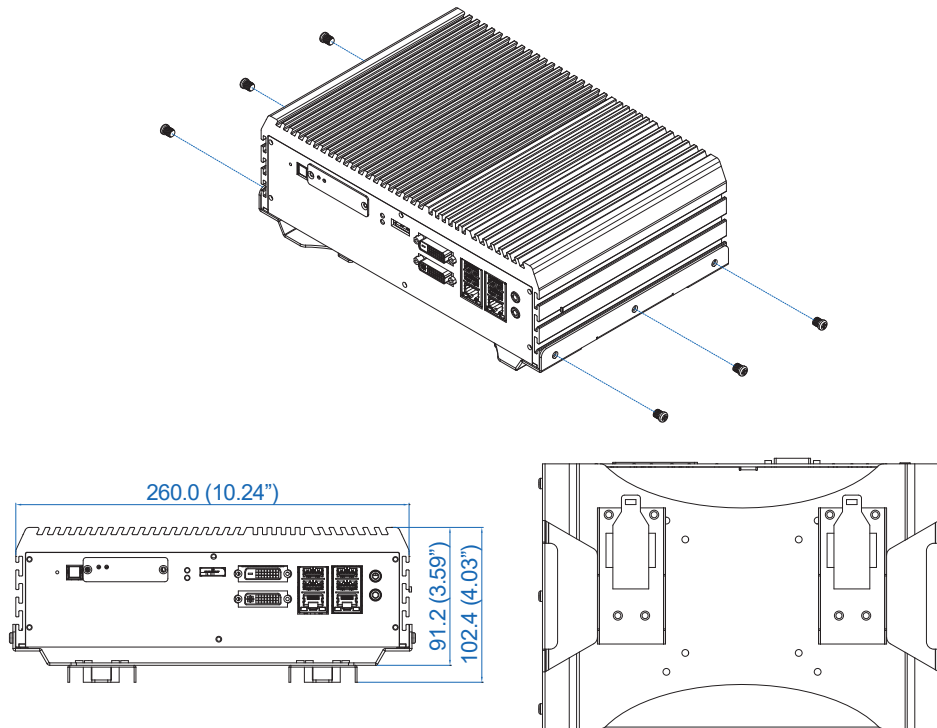

3.10.4 2U rack mount kit

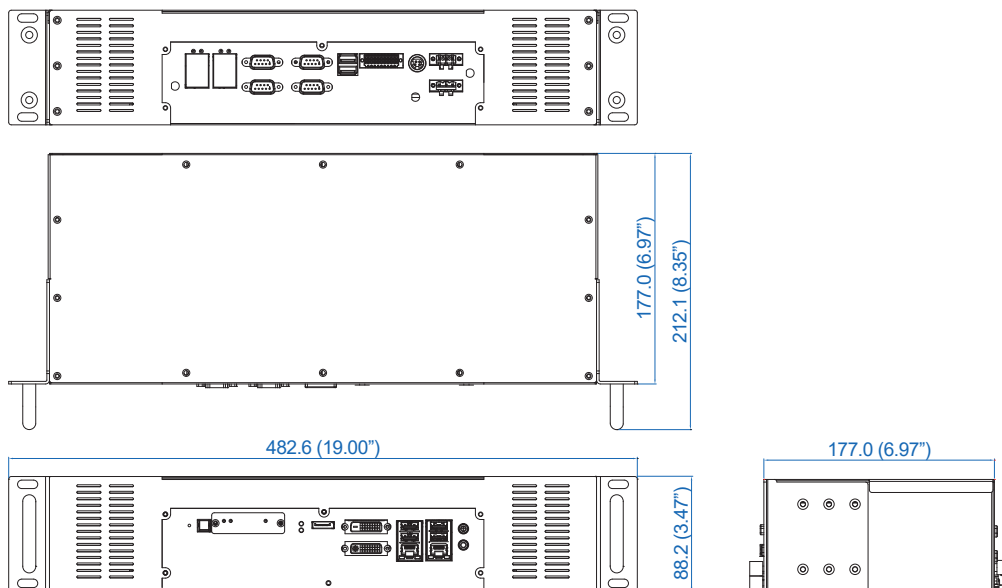

4

BIOS SETUP

4.1 Entering BIOS Setup

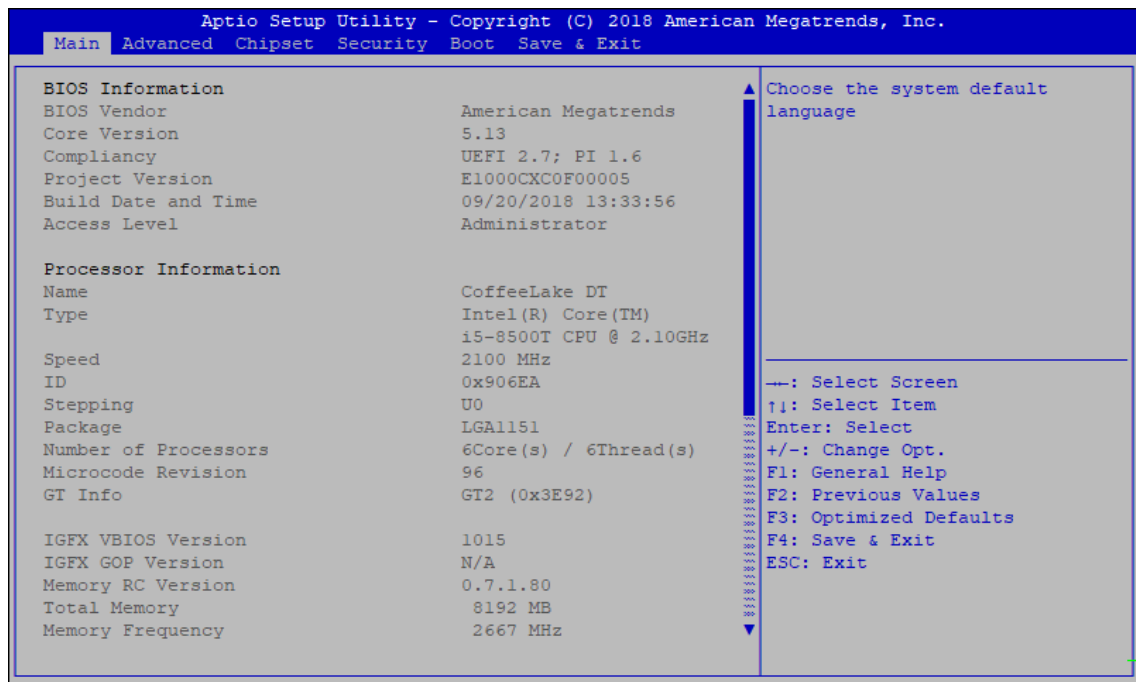

Figure 4-1 : Entering Setup Screen

BIOS provides an interface for users to check and change system configuration. The BIOS setup program is accessed by pressing the key when POST display output is shown.

4.2 Main

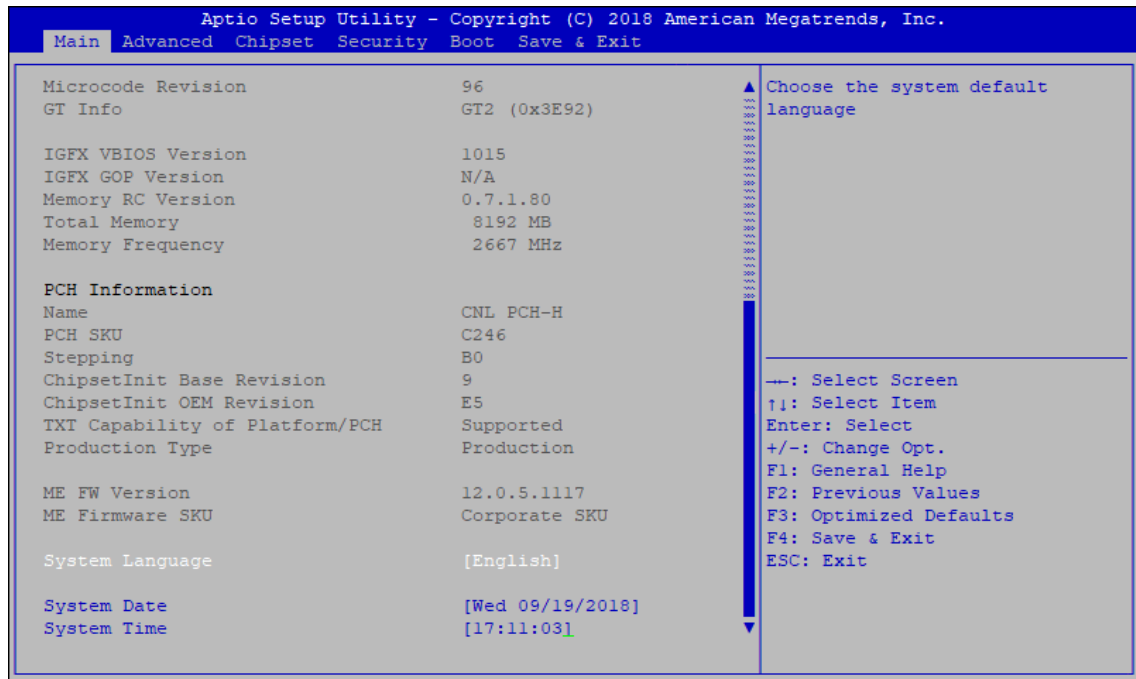

Figure 4-2 : BIOS Main Menu

The main menu displays BIOS version and system information. There are two options on Main menu.

System Date

Set the date. Use <Tab> to switch between date elements.

System Time

Set the time. Use <Tab> to switch between time elements.

4.3 Advanced

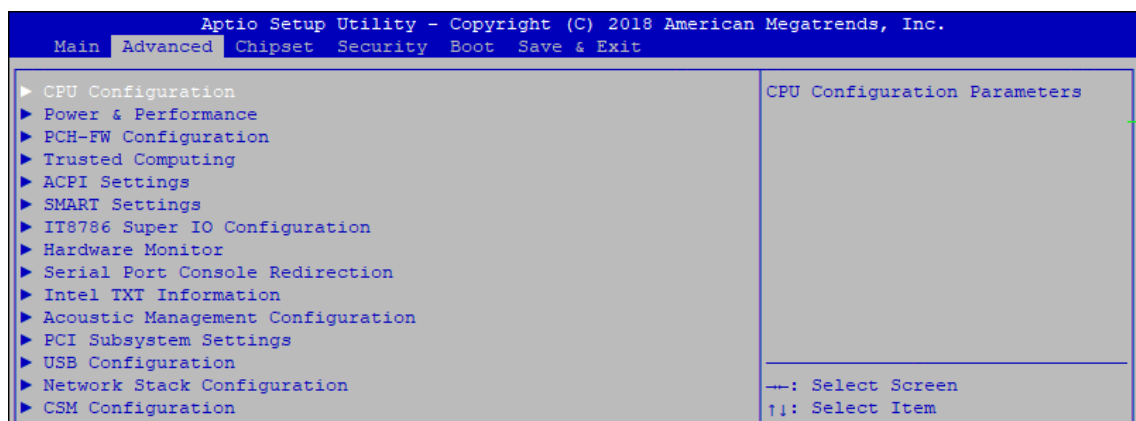

Figure 4-3 : BIOS Advanced Menu

Select advanced tab to enter advanced BIOS setup options, such as CPU configuration, SATA configuration, and USB configuration.

4.3.1 CPU Configuration

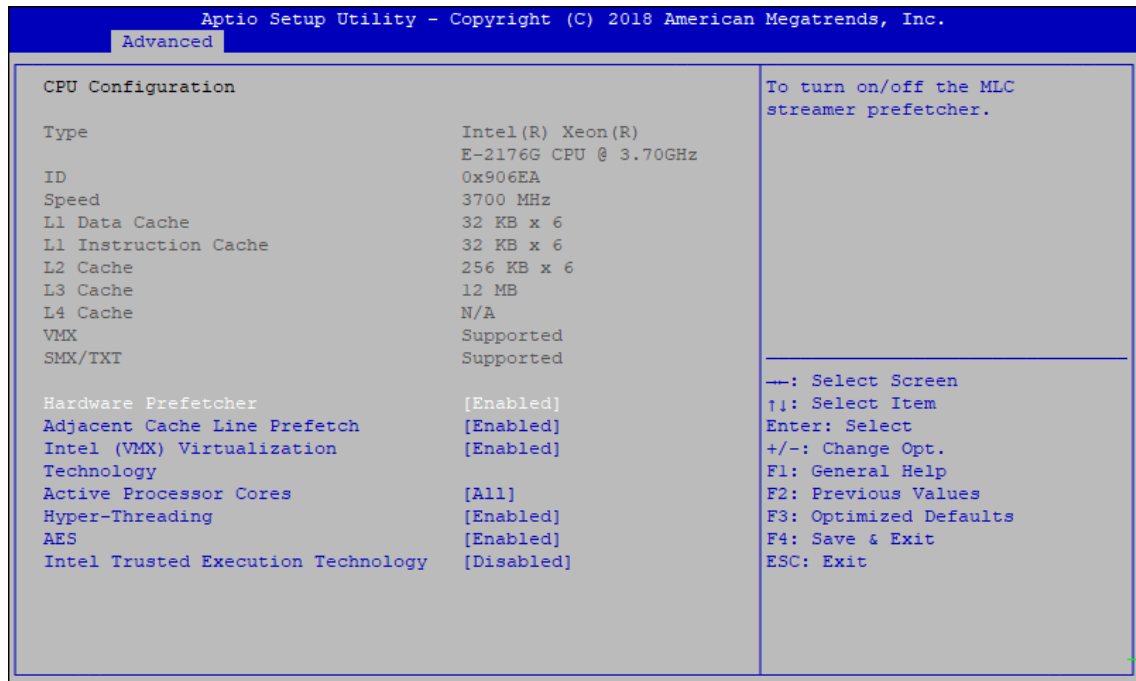

Figure 4-3-1 : CPU Configuration

Hardware Prefetcher

To turn on/off the MLC streamer prefetcher.

Adjacent Cache Line Prefetch

To turn on/off prefetching of adjacent cache lines.

Intel (VMX) Virtualization Technology

When enabled, a VMM can utilize the additional hardware capabilities provided by Vanderpool Technology.

Active Processor Cores

Number of cores to enable in each processor package.

Hyper-threading

Enabled for Windows XP and Linux (OS optimized for Hyper-Threading Technology) and disabled for other OS (OS not optimized for Hyper-Threading Technology). When disabled only one thread per core is enabled.

AES

Enable/disable CPU Advanced Encryption Standard instructions.

Intel Trusted Execution Technology

Enables utilization of additional hardware capabilities provided by Intel® Trusted Execution Technology.

Changes require a full power cycle to take effect.

4.3.2 Power & Performance

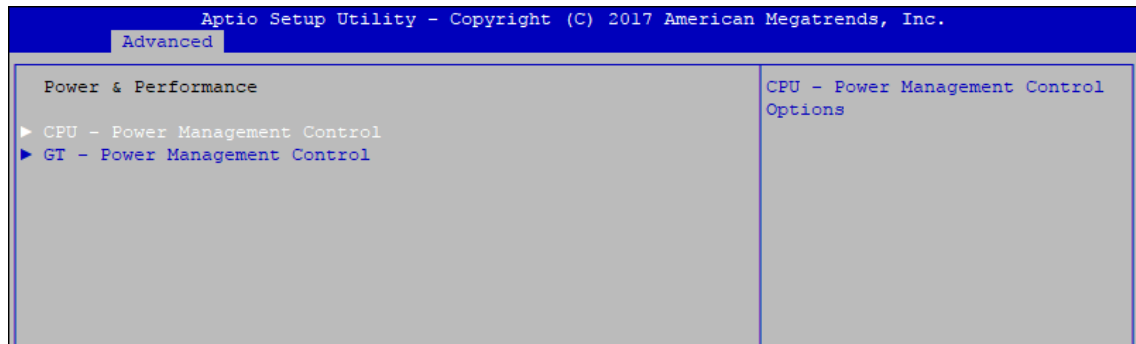

Figure 4-3-2 : Power & Performance

4.3.2.1 CPU – Power Management Control

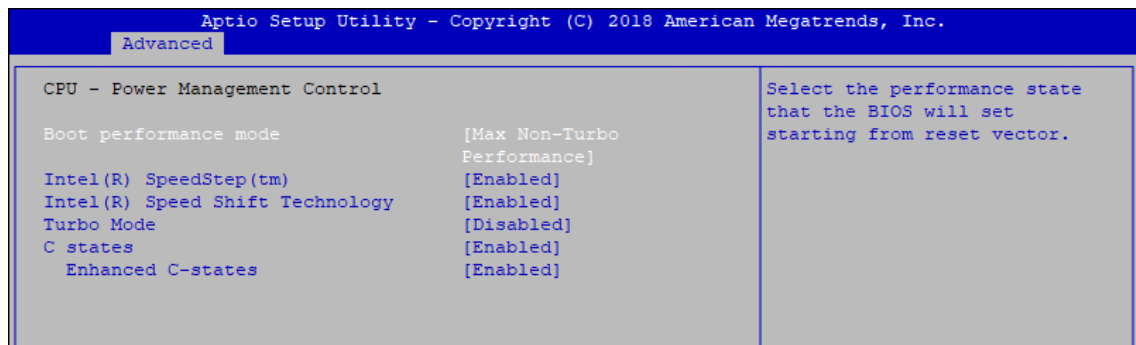

Figure 4-3-2-1 : CPU – Power Management Control

Boot performance mode

Select the performance state that the BIOS will set before OS handoff.

Intel(R) SpeedStep(tm)

Allows more than two frequency ranges to be supported.

Intel(R) Speed shift Technology

Enable/Disable Intel® Speed Shift Technology support. Enabling will expose the CPPCV2 interface to allow for hardware controlled P-states.

Turbo Mode

Turbo Mode.

C states

Enable or disable CPU C states.

Enhanced C-states

Enable/disable C1E. When enabled, CPU will switch to minimum speed when all cores enter C-State.

4.3.2.2 GT – Power Management Control

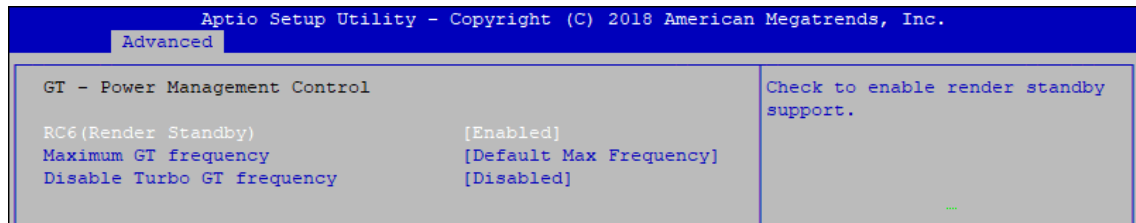

Figure 4-3-2-2 : GT – Power Management Control

RC6 (Render Standby)

Check to enable render standby support.

Maximum GT frequency

Maximum GT frequency is limited by the user. Choose between 350MHz (RPN) and 1150MHz (RP0). Value beyond the range will be clopped to min/max supported by SKU

Disable Turbo GT frequency

Check to enable render standby support.

4.3.3 PCH-FW Configuration

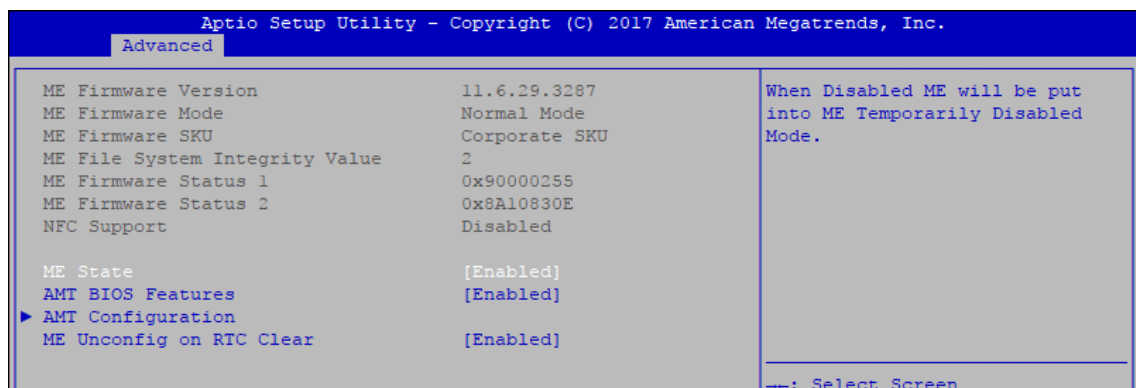

Figure 4-3-3 : PCH-FW Settings

ME State

Set ME to Soft temporarily disabled.

AMT BIOS Features

When disable AMT BIOS Features, they will be no longer supported and user is no longer able to access MEBx Setup.

AMT Configuration

Configure Intel® Active Management Technology Parameters.

ME Unconfig on RTC Clear State

Disabling this option will cause ME not to unconfigure on RTC clear.

4.3.4 Trusted Computing

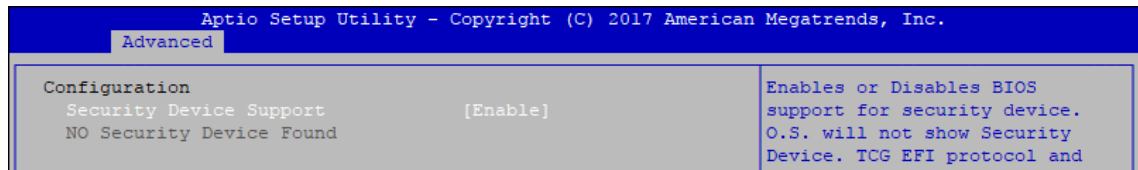

Figure 4-3-4 : Trusted Computing

Control the TPM device status and display related information if TPM chip is present.

4.3.5 ACPI Settings

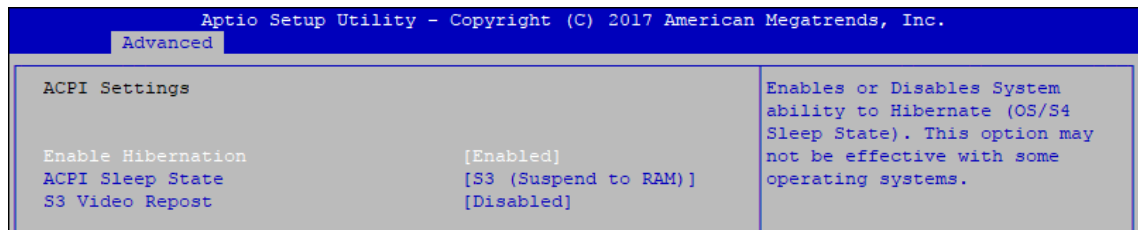

Figure 4-3-5 : ACPI Settings

Enable Hibernation

Enables or disables system's ability to hibernate (OS/S4 sleep state). This option may not be effective with some OS.

ACPI Sleep State

Selects the highest ACPI sleep state the system will enter when the SUSPEND button is pressed.

S3 Video Repost

Enables or disables S3 video repost.

4.3.6 SMART Settings

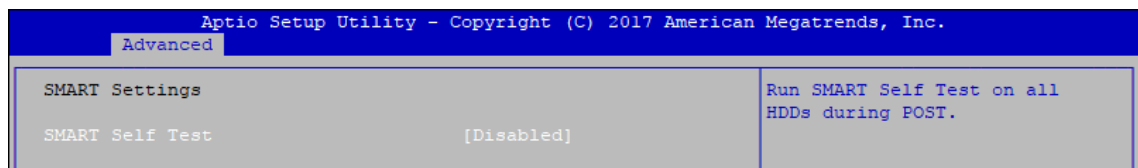

Figure 4-3-6 : SMART Settings

SMART Self Test

Run SMART self test on all HDDs during POST.

4.3.7 IT8786 Super IO Configuration

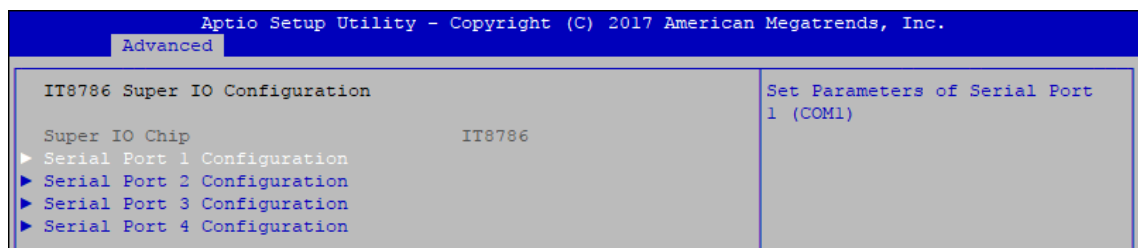

Figure 4-3-7 : IT8786 Super IO Settings

4.3.7.1 Serial Port X Configuration

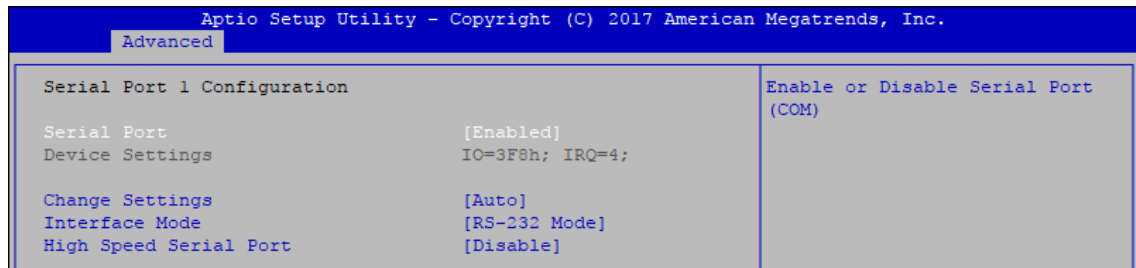

Figure 4-3-7-1 : Serial Port X Configuration

Serial Port 1 to port 4 Configuration

Options for Serial Port 1 to Serial Port 4.

Entering the corresponding Port option then end user can change the settings such as I/O resource and UART mode (High Speed Serial Port is Port 1 only).

4.3.8 Hardware Monitor

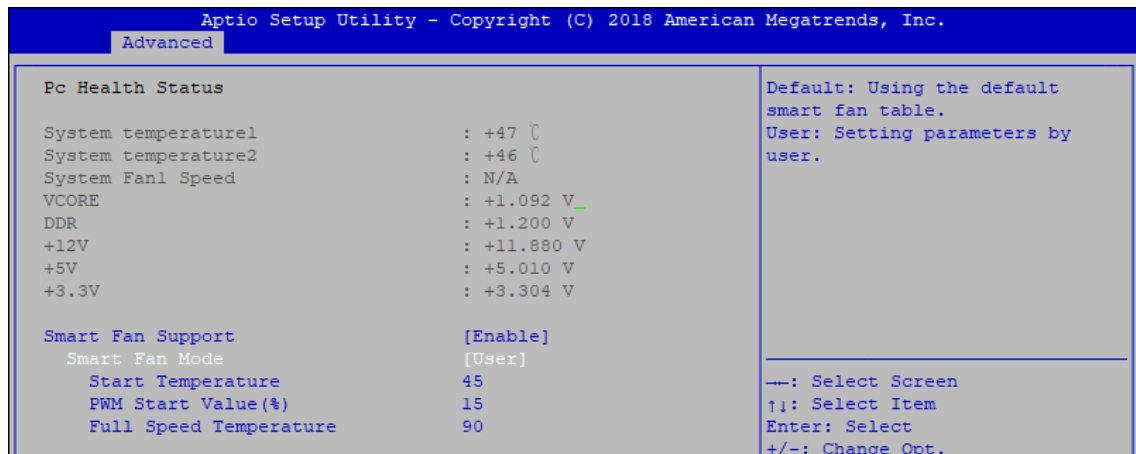

Figure 4-3-8 : Hardware Monitor Settings

The IT8786 SIO features an enhanced hardware monitor providing thermal, fan speed, and system voltages' status monitoring.

Smart Fan Support

Smart Fan Support. Work with Full Speed if "Smart Fan Support" is Disabled.

Smart Fan Mode

Default : Using the default smart fan table.

User : Setting parameters by user.

Start Temperature

Temperature Limit value of Fan Start (Degree C).

(Range : 10~80)

PWM Start Value (%)

Default PWM Value of Fan.

(Range : 15%~100%)

Full Speed Temperature

Temperature Limit value of Fan Full Speed (Degree C).

(Range : 50~90)

4.3.9 Serial Port Console Redirection

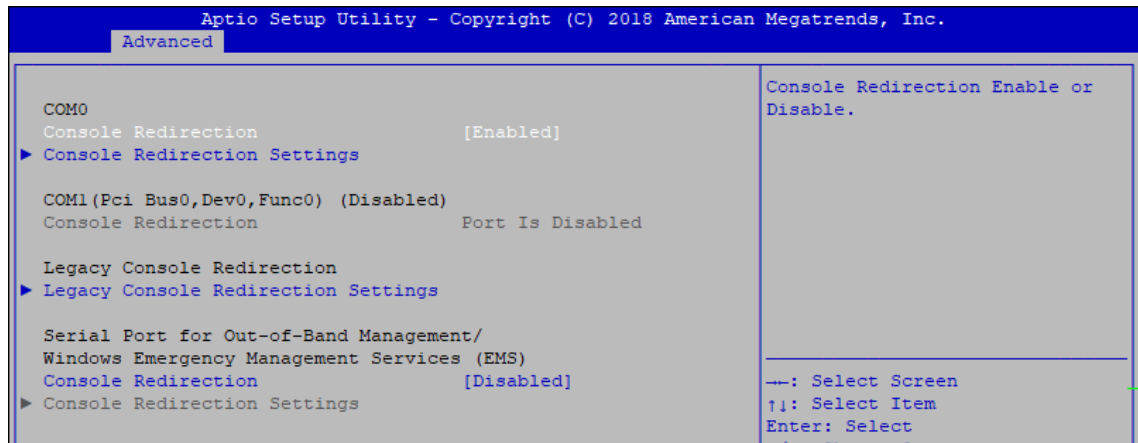

Figure 4-3-9 : Serial Port Console Redirection Settings

Console Redirection

Console redirection enable or disable.

Console Redirection Settings

These settings specify how the host computer and the remote computer (which the user is using) will exchange data. Both computers should have the same or compatible settings.

Legacy Console Redirection

Legacy Console Redirection Settings.

Serial Port for Out-of-Band Management/Windows Emergency Management Services (EMS)

Console redirection enable or disable.

4.3.10 Intel TXT Information

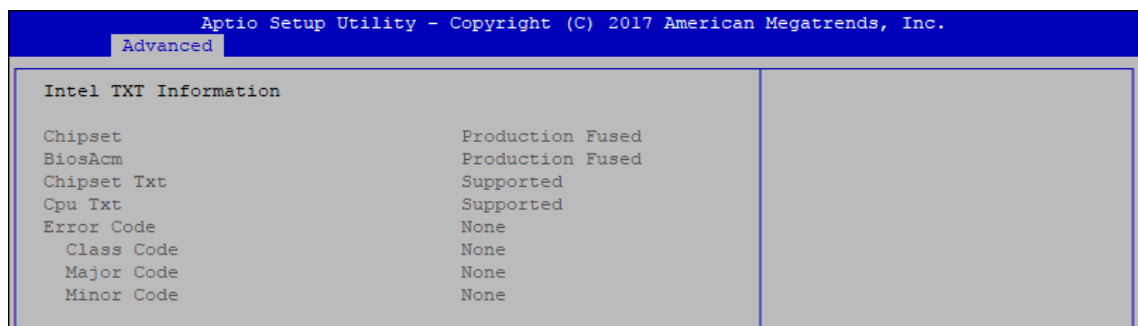

Figure 4-3-10 : Intel TXT Information

Display Intel TXT information.

4.3.11 Acoustic Management Configuration



Figure 4-3-11 : Acoustic Management Settings

Acoustic Management Configuration

Option to enable or disable automatic acoustic management.

4.3.12 PCI Subsystem Setting

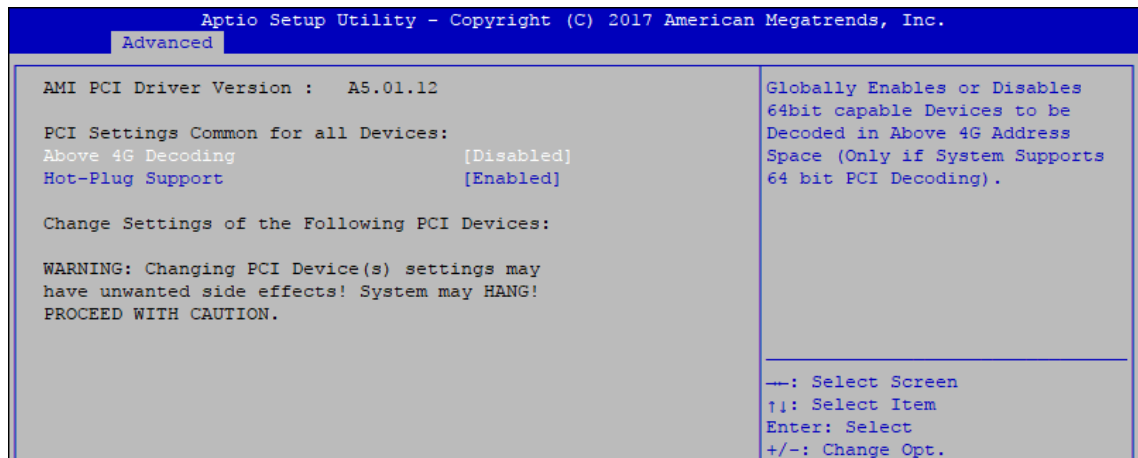

Figure 4-3-12 : PCI Subsystem Settings

Above 4G Decoding

Globally Enables or Disables 64bit capable Devices to be Decoded in Above 4G Address Space (Only if System Supports bot PCI Decoding)

Hot-Plug Support

Globally Enables or Disables Hot-Plug support for the entire System. If system has Hot-Plug Capable Slots and this option set to Enabled, it provides a Setup screen for selecting PCI resource padding for Hot-Plug.

4.3.13 Network Stack Configuration

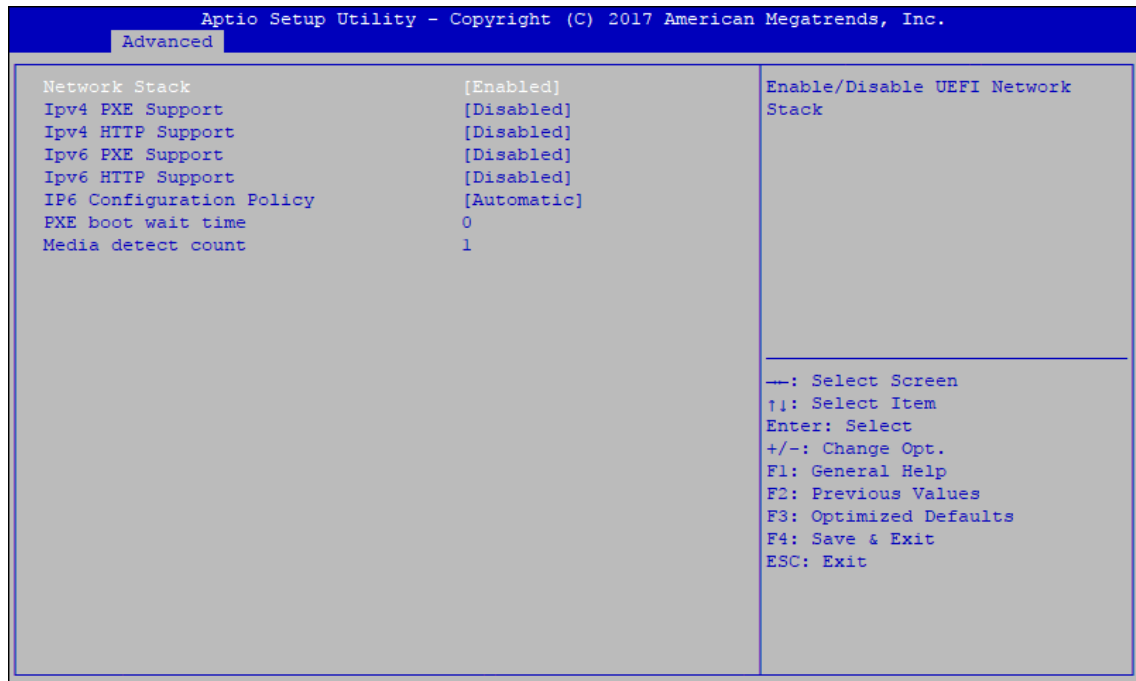

Figure 4-3-13 : Network Stack Settings

Network Stack

Enable/Disable UEFI Network Stack

Ipv4 PXE Support

Enable/Disable IPv4 PXE boot support.

Ipv4 HTTP Support

Enable/Disable IPv4 HTTP boot support.

Ipv6 PXE Support

Enable/Disable IPv6 PXE boot support.

Ipv6 HTTP Support

Enable/Disable IPv6 HTTP boot support.

IP6 Configuration Policy

Set IP6 Configuration Policy.

PXE boot wait time

Wait time to press ESC key to abort the PXE boot.

Media detect count

Number of times presence of media will be checked.

4.3.14 CSM Configuration

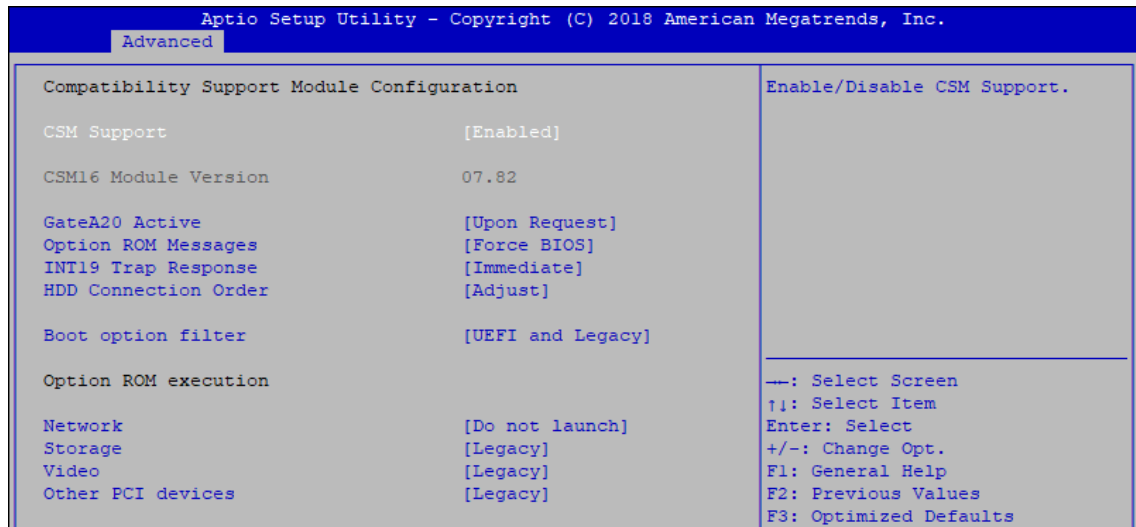

Figure 4-3-14 : CSM Configuration

CSM Support

Enable/disable CSM support

GateA20 Active

UPON REQUEST - GA20 can be disabled using BIOS services.

ALWAYS - do not allow GA20 to be disabled; this option is useful when any RT code is executed above 1MB.

Option ROM Messages

Set display mode for Option ROM.

INT19 Trap Response

BIOS reaction on INT19 trapping by Option ROM :

IMMEDIATE - execute the trap right away;

POSTPONED - execute the trap during legacy boot.

HDD Connection Order

Some OS require HDD handles to be adjusted, i.e. OS is installed on drive 80h.

Boot option filter

This option controls Legacy/UEFI ROM's priority.

Network

Controls the execution of UEFI and Legacy PXE OpROM.

Storage

Controls the execution of UEFI and Legacy Storage OpROM.

Video

Allows more than two frequency ranges to be supported.

Other PCI devices

Determines OpROM execution policy for devices other than network, storage, or video.

4.3.15 NVMe Configuration

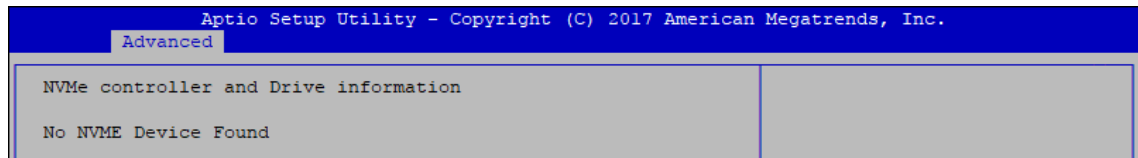

Figure 4-3-15 : NVMe Settings

Display NVMe controller and Drive information.

4.3.16 USB Configuration

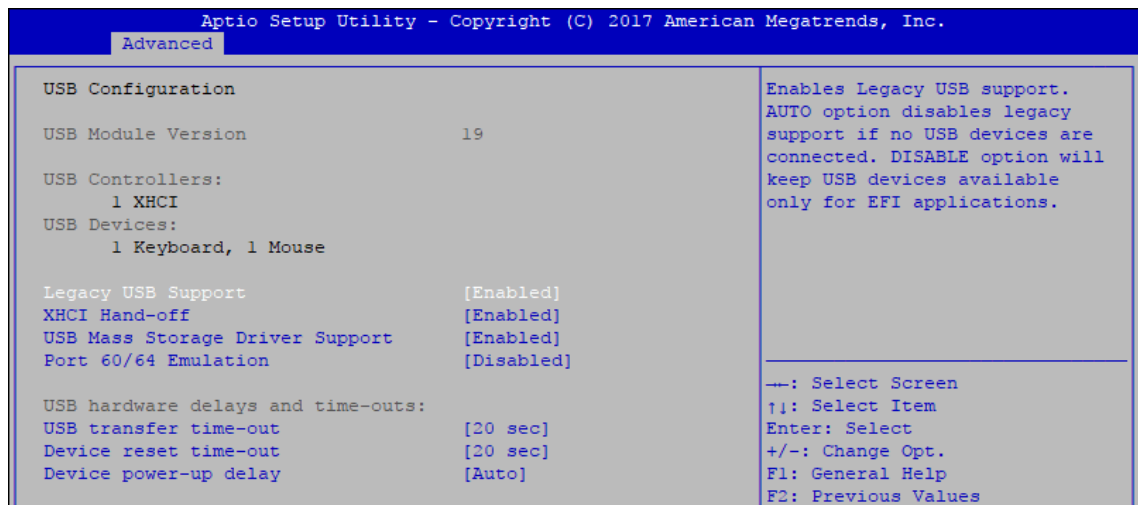

Figure 4-3-16 : USB Settings

Legacy USB Support

Enables Legacy USB support.

AUTO option disables Legacy support if no USB devices are connected.

DISABLE option will keep USB devices available only for EFI applications.

XHCI Hand-off

This is a workaround for OS-es without XHCI hand-off support. The XHCI ownership change should be claimed by XHCI driver.

USB Mass Storage Driver Support

Enable/disable USB mass storage driver support.

Port 60/64 Emulation

Enables I/O port 60h/64h emulation support. This should be enabled for the complete USB keyboard legacy support for non-USB aware OSes.

USB transfer time-out

The time-out value for control, bulk, and interrupt transfers.

Device reset time-out

USB mass storage device start unit command time-out.

Device power-up delay

Maximum time the device will take before it properly reports itself to the Host Controller. 'Auto' uses default value, for a root port it is 100 ms, for a hub port the delay is taken from the hub descriptor.

4.4 Chipset

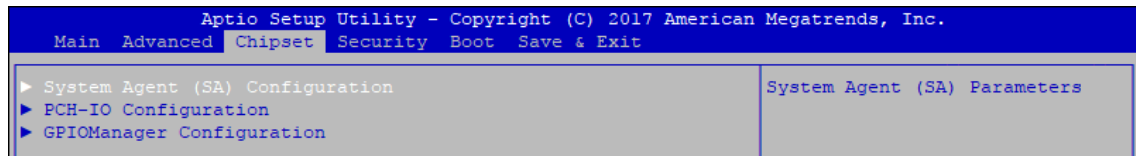

Figure 4-4 : BIOS Chipset Menu

System Agent (SA) Configuration

System Agent (SA) parameters.

PCH-IO Configuration

PCH parameters.

GPIOManager Configuration

GPIOManager Configuration.

4.4.1 System Agent (SA) Configuration

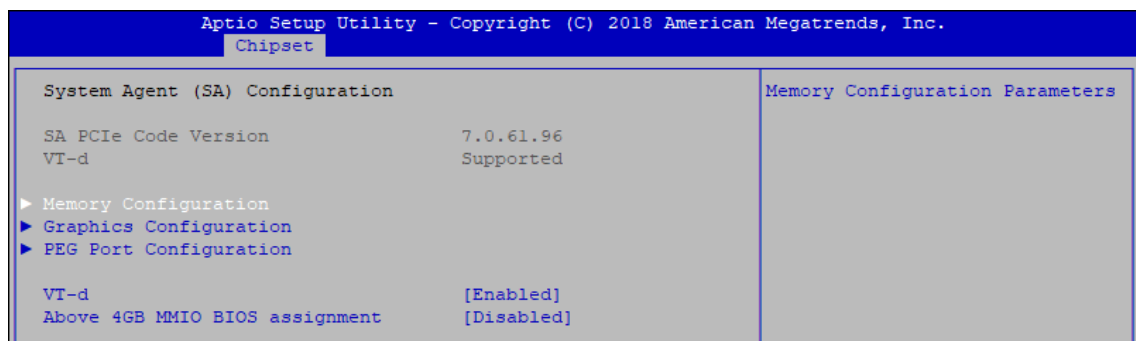

Figure 4-4-1 : System Agent Settings

VT-d

VT-d capability.

Above 4GB MMIO BIOS assignment

Enable/disable above 4GB MemoryMappedIO BIOS assignment. This is disabled automatically when aperture size is set to 2048MB.

4.4.1.1 Memory Configuration

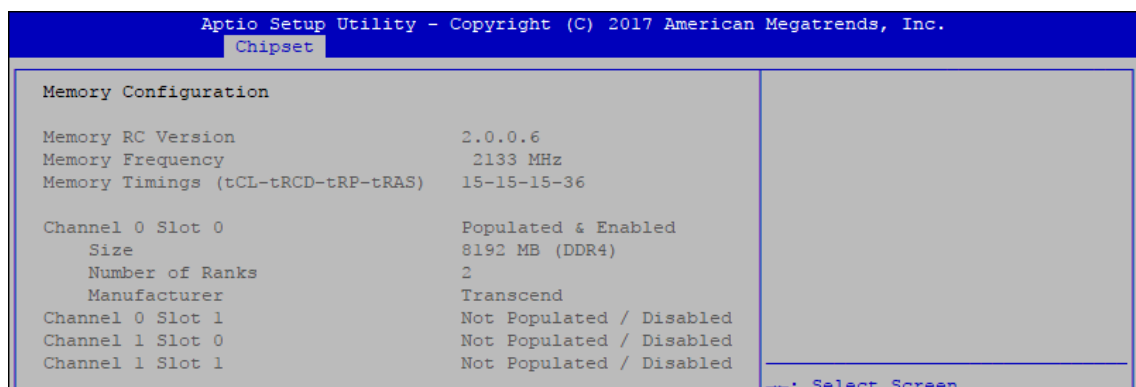

Figure 4-4-1-1 : Memory Information

Displays memory information.

4.4.1.2 Graphics Configuration

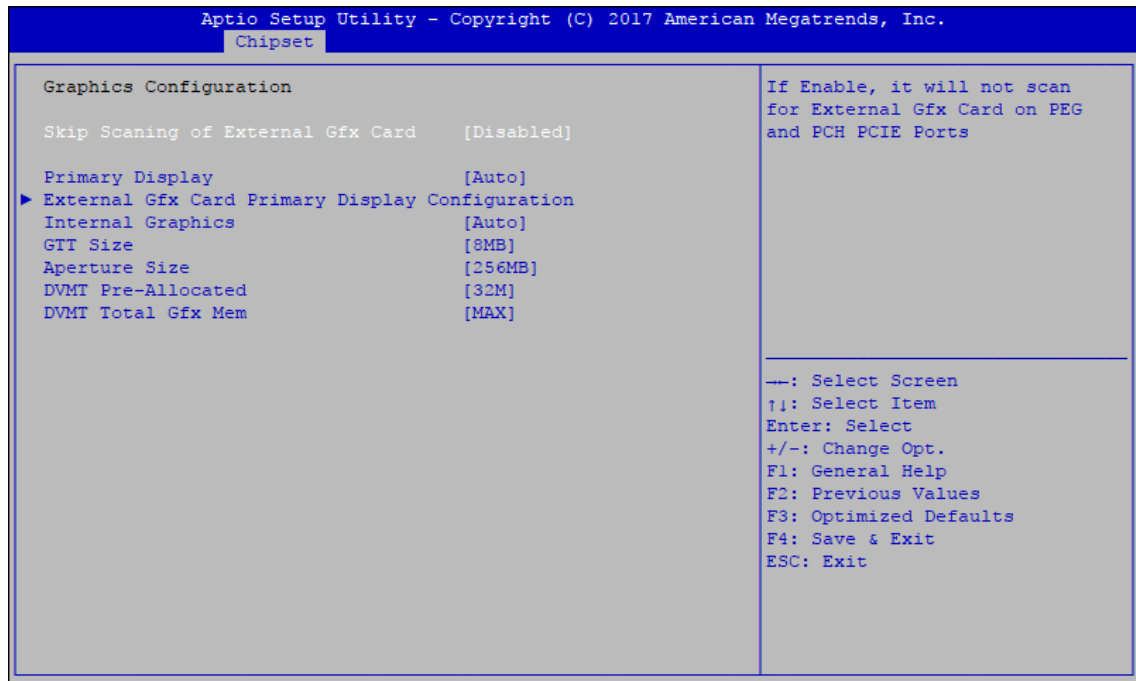

Figure 4-4-1-2 : Graphics Settings

Skip Scanning of External Gfx Card

If Enable, it will not scan for External Gfx Card on PEG and PCH PCIE Ports.

Primary Display

Select which of IGFX/PEG/PCI Graphics device should be Primary Display Or select SG for Switchable Gfx.

Internal graphics

Keep IGFX enabled based on the setup options.

GTT Size

Select the GTT Size.

Aperture Size

Select the Aperture Size.

Note : Above 4GB MMIO BIOS assignment is automatically enabled when selecting 2048MB aperture. To use this feature, please disable CSM Support.

DVMT Pre-Allocated

Select DVMT 5.0 Pre-Allocated (Fixed) Graphics Memory size used by the Internal Graphics Device.

DVMT Total Gfx Mem

Select DVMT5.0 Total Graphic Memory size used by the Internal Graphics Device.

4.4.1.3 PEG Port Configuration

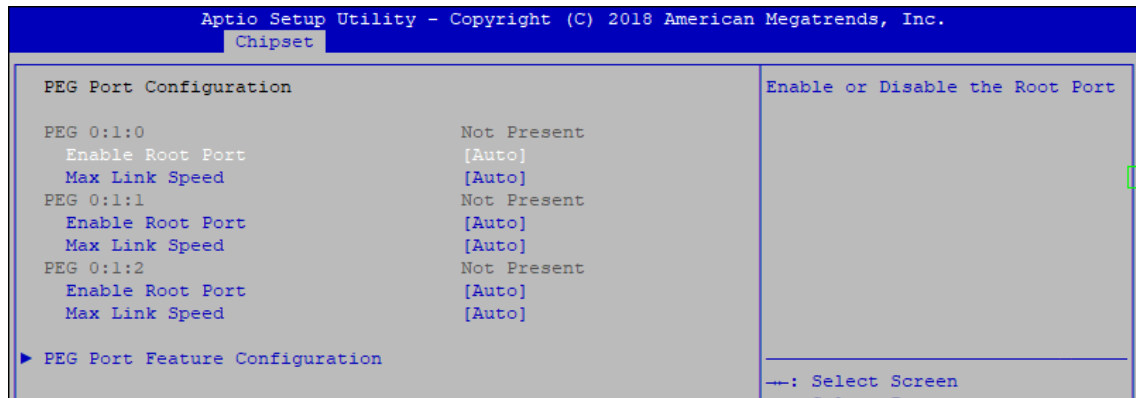

Figure 4-4-1-3 : PEG Port Configuration

PEG port options for PCIe device.

4.4.2 PCH-IO Configuration

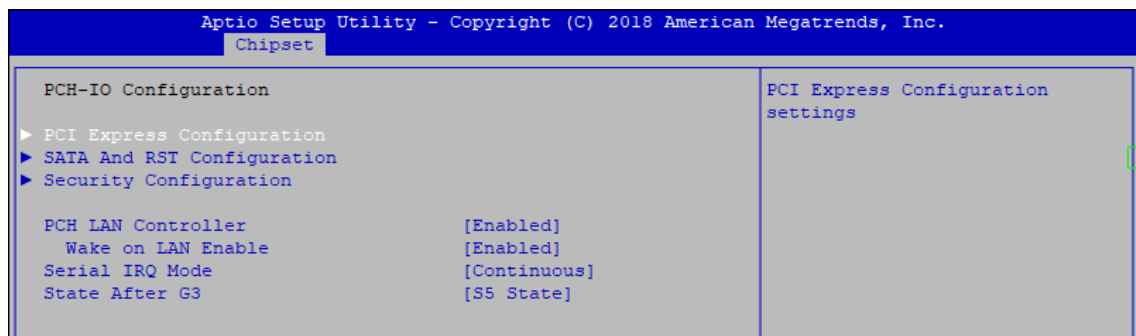

Figure 4-4-2 : PCH-IO Settings

PCH LAN Controller

Enable or disable onboard NIC.

Wake on LAN

Enable or disable integrated LAN to wake the system. (The wake On LAN cannot be disabled if ME is on at Sx state.)

Serial IRQ Mode

Configure serial IRQ mode.

State After G3

Specify what state to go to when power is re-applied after a power failure (G3 state).

S0 State : Always turn-on the system when power source plugged-in.

S5 State : Always turn-off the system when power source plugged-in.

4.4.2.1 PCI Express Configuration of PCH-IO

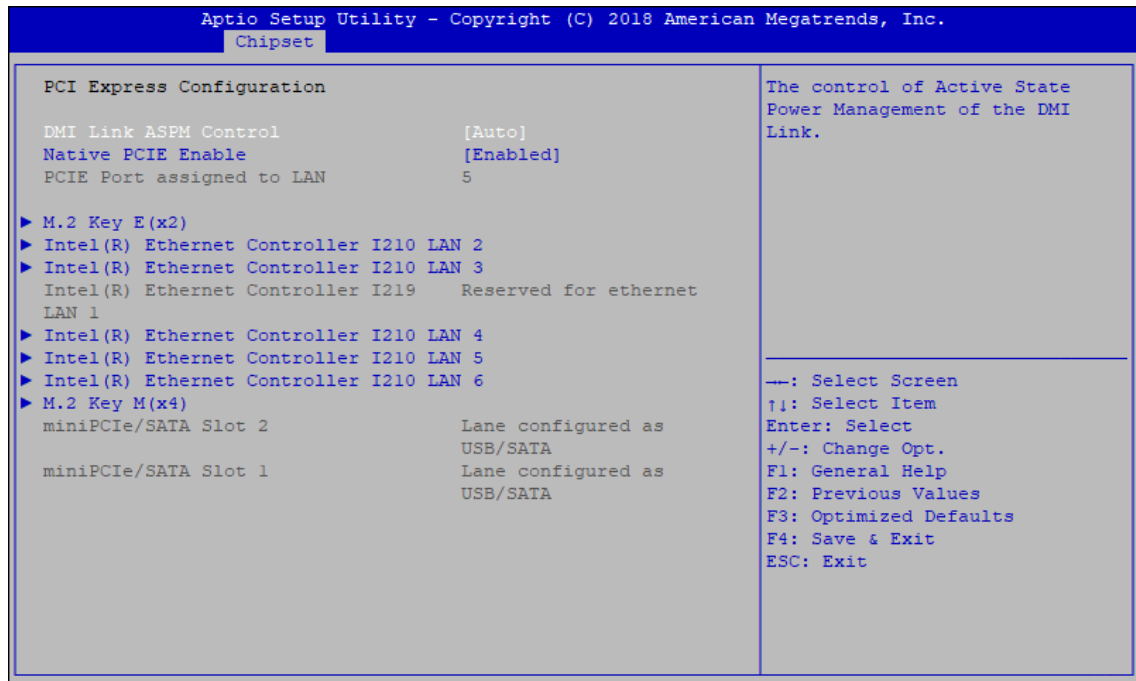

Figure 4-4-2-1 : PCH-IO Settings

DMI Link ASPM Control

Enable/Disable the control of Active State Power Management on SA side of the DMI Link.

Native PCIE Enable

PCIE Express Native Support Enable/Disable.

PCI Express device settings

Bios options for PCI Express device setting.

4.4.2.2 SATA and RST Configuration

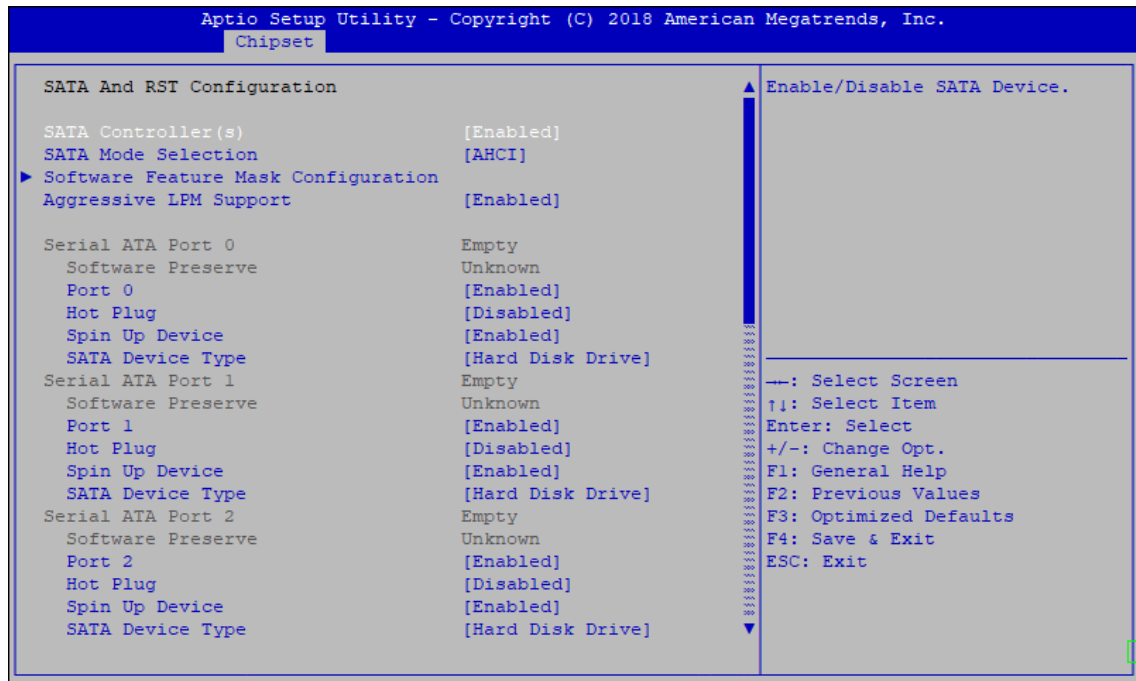

Figure 4-4-2-2 : SATA and RST Settings

SATA Controller(s)

Enable or disable SATA Device.

SATA Mode Selection

Determines how SATA controller(s) operate.

Software Feature Mask Configuration

RAID OROM/RST driver will refer to the SWFM configuration to enable or disable the storage features.

Aggressive LPM Support

Enable PCH to aggressively enter link power state.

Options for each SATA port :

Port n

Enable or disable SATA Port.

Hot Plug

Designated this port as Hot Pluggable.

Spin Up Device

On an edge detect from 0 to 1, the PCH starts a COMRESET initialization sequence to the device.

SATA Device Type

Identifies that the SATA port is connected to solid state drive or hard disk drive.

4.4.2.3 Security Configuration

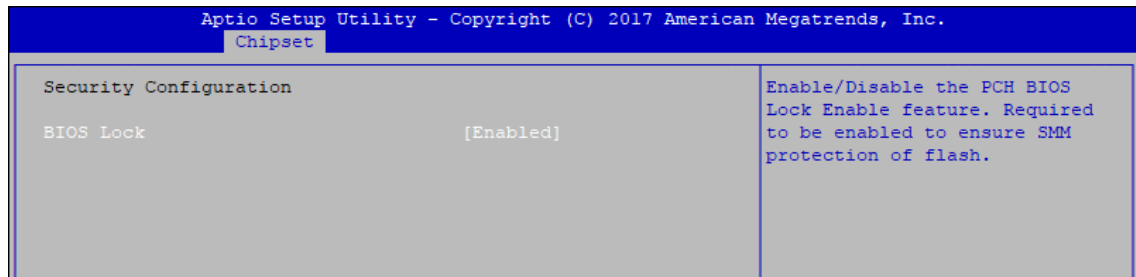

Figure 4-4-2-3 : Security Settings

BIOS Lock

Enable/disable the PCH BIOS Lock Enable (BLE bit) feature.

4.5 Security

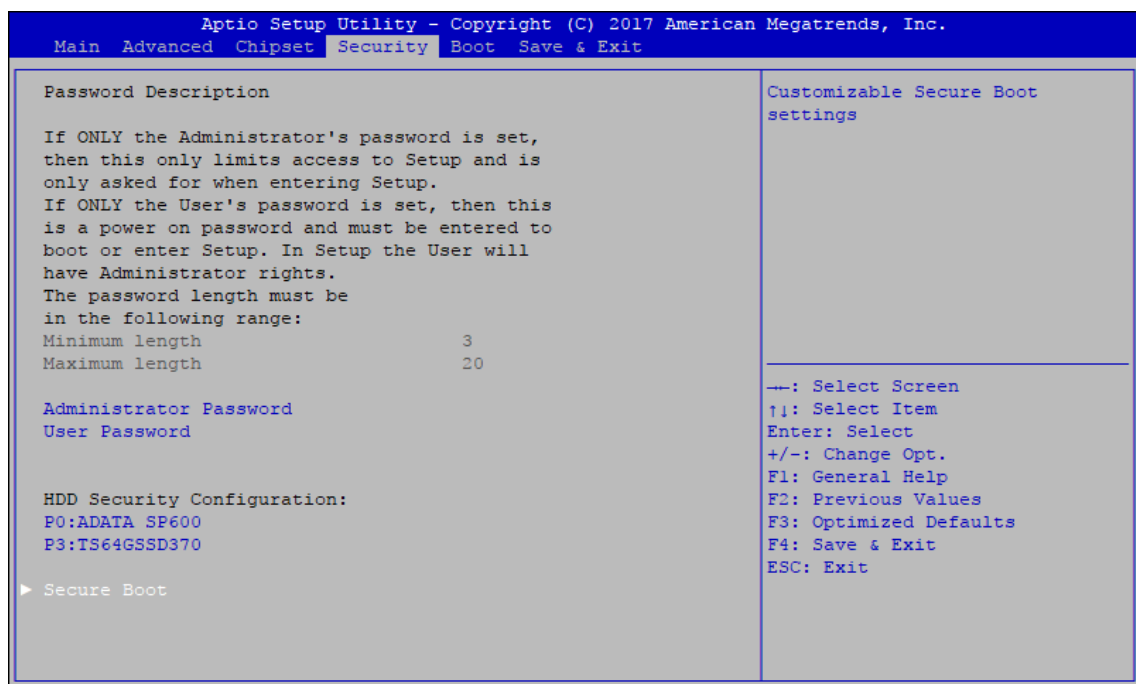

Figure 4-5 : BIOS Security Menu

Administrator Password

Set administrator password.

User Password

Set user password.

Secure Boot

Customizable Secure Boot Settings.

4.5.1 HDD Security Configuration

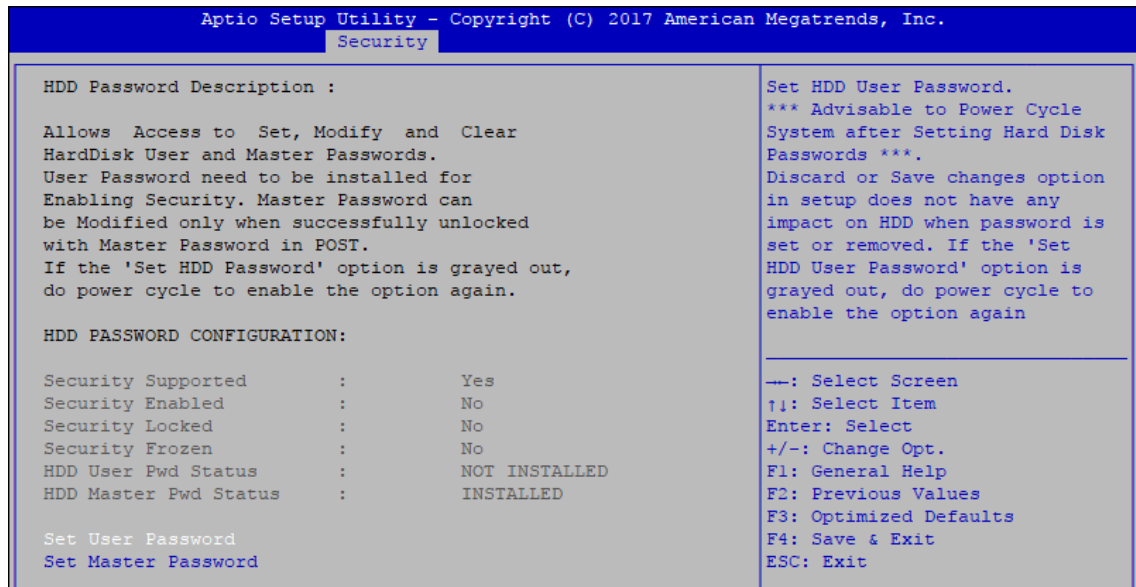

Figure 4-5-1 : HDD Security Settings

Set User Password

Set HDD user password.

*** Advisable to power cycle system after setting hard disk passwords ***

Discard or save changes option in setup does not have any impact on HDD when password is set or removed. If the 'Set HDD User Password' option is gray, do power cycle to enable the option again.

4.5.2 Security Boot

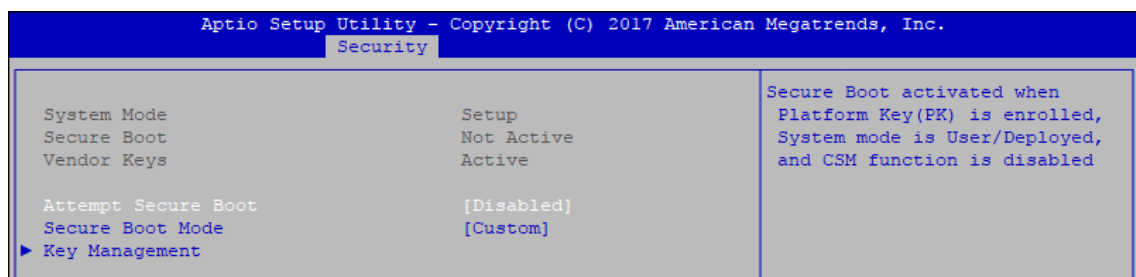

Figure 4-5-2 : Security Boot Settings

Attempt Secure Boot

Secure Boot activated when Platform Key (PK) is enrolled, System mode is User/Deployed, and CSM function is disabled.

Secure Boot Mode

Secure Boot mode selector Standard/Custom.

In custom mode Secure Boot Variables can be configured without authentication.

Key Management

Enables expert users to modify Secure boot policy variables without full authentication.

4.6 Boot

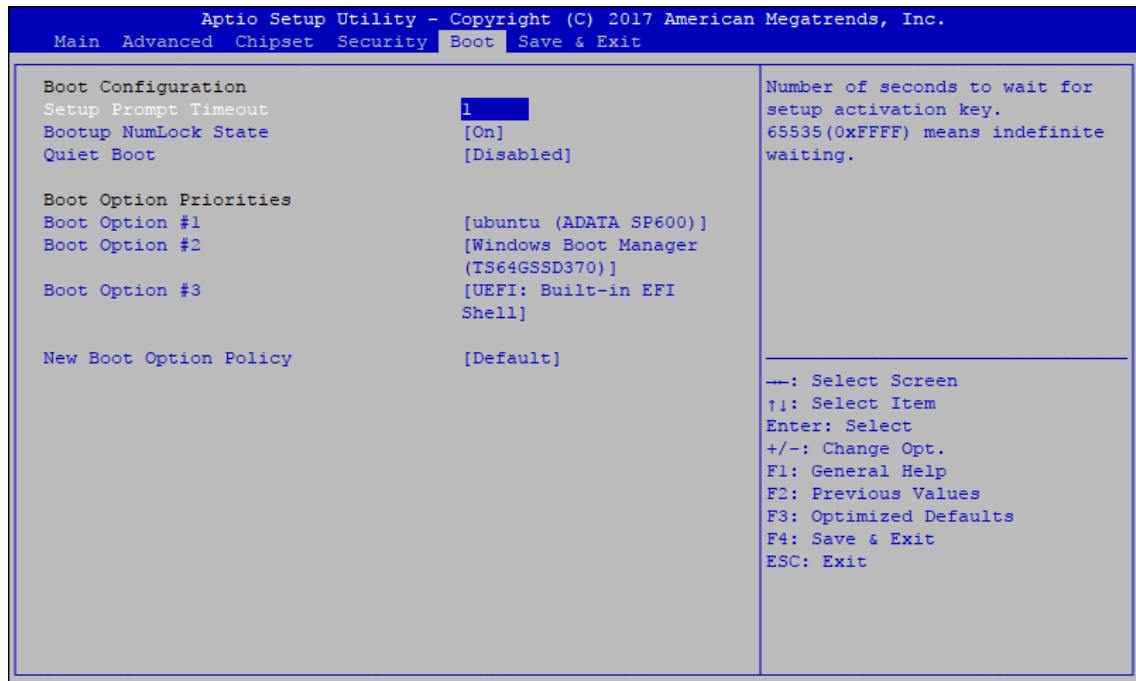

Figure 4-6 : BIOS Boot Menu

Setup Prompt Timeout

Number of seconds to wait for setup activation key. 65535 (0xFFFF) means indefinite waiting.

Bootup NumLock State

Select the keyboard NumLock state.

Quiet Boot

Enables or disables Quiet Boot option.

Boot Option

Sets the system boot order.

New Boot Option Policy

Controls the placement of newly detected UEFI boot options.

Hard Drive BBS Priorities

Set the order of the Legacy devices in this group.

4.7 Save & Exit

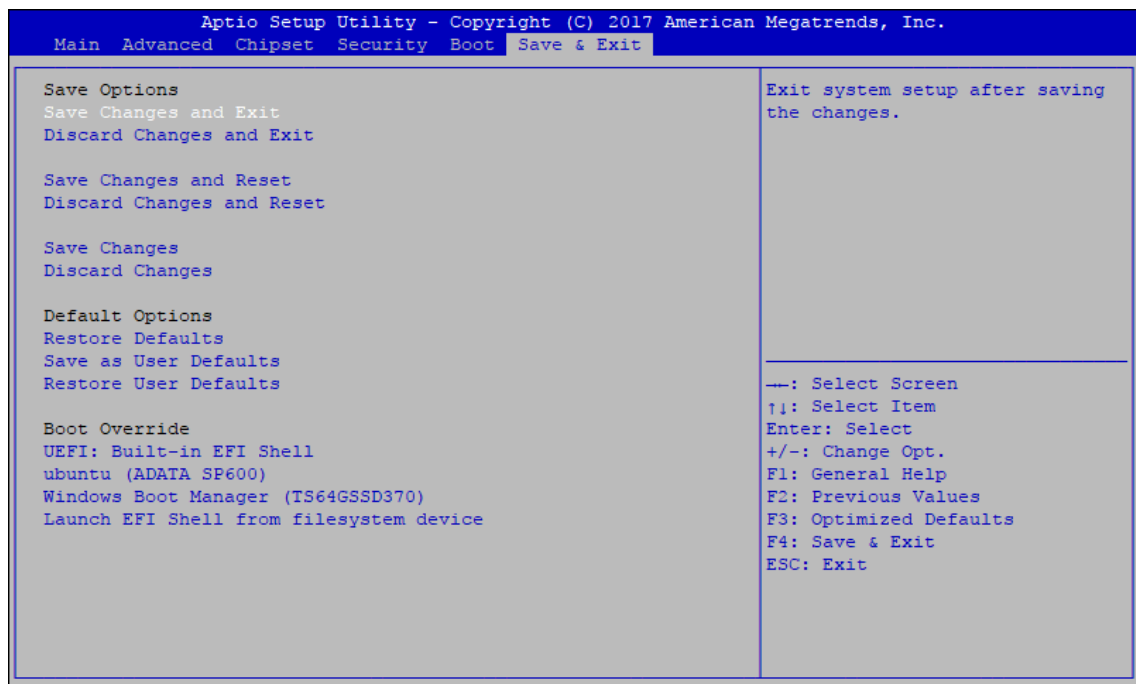

Figure 4-7 : BIOS Save and Exit Menu

Save Changes and Exit

Exit system setup after saving the changes.

Discard Changes and Exit

Exit system setup without saving any changes.

Save Changes and Reset

Reset the system after saving the changes.

Discard Changes and Reset

Reset system setup without saving any changes.

Save Changes

Save Changes done so far to any of the setup options.

Discard Changes

Discard Changes done so far to any of the setup options.
Default Options.

Restore Defaults

Restore/Load Default values for all the setup options.

Save as User Defaults

Save the changes done so far as User Defaults.

Restore User Defaults

Restore the User Defaults to all the setup options.

A

APPENDIX A : Isolated DIO Guide

A.1 Function Description

The Echo 246F offers a 16-bit DIO (Isolated/Non-Isolated) 20-pin terminal block connector, a watchdog timer, and a 4-port POE.

Isolated DIO pins are fixed by Hardware design that cannot change in/out direction in runtime process.

DIO definition is shown below :

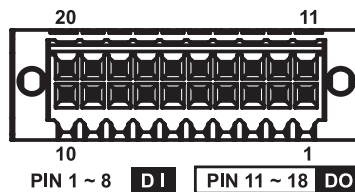

Pin No.	DIO Definition	GPIO Definition	Pin No.	DIO Definition	GPIO Definition
1	DI 0	DIO 0	11	DO 0	DIO 8
2	DI 1	DIO 1	12	DO 1	DIO 9
3	DI 2	DIO 2	13	DO 2	DIO 10
4	DI 3	DIO 3	14	DO 3	DIO 11
5	DI 4	DIO 4	15	DO 4	DIO 12
6	DI 5	DIO 5	16	DO 5	DIO 13
7	DI 6	DIO 6	17	DO 6	DIO 14
8	DI 7	DIO 7	18	DO 7	DIO 15
9	DI COM	NC	19	DIO_GND	DIO_GND
10	DIO_GND	DIO_GND	20	External VDC	NC

POE definition is shown below :

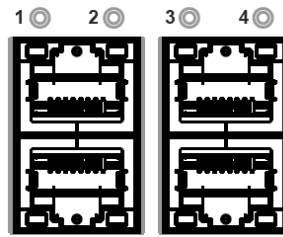

Port No.	Definition	Port No.	Definition
1	POE 0	3	POE 2
2	POE 1	4	POE 3

Do NOT use these functions in below :

1. PE-2000 : DIO1 (ID = 0), POE
2. PE-3000 : POE (ID = 0)
3. UE-1000 : USB (ID = 0)

A.2 Isolated DIO Signal Circuit

DI reference circuit :

Sink Mode (NPN)

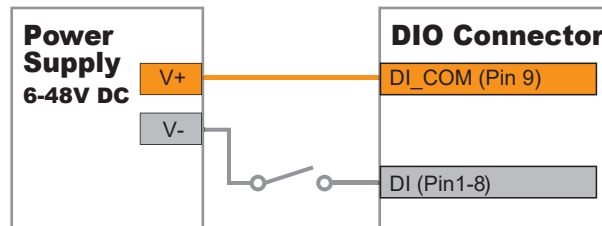

Source Mode (PNP)

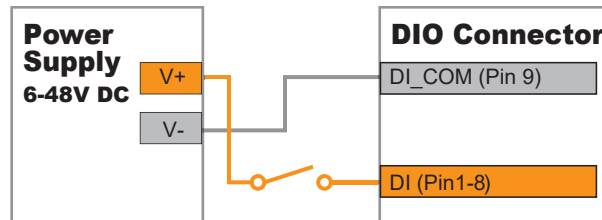

DO reference circuit :

Sink Mode
(NPN, Default)

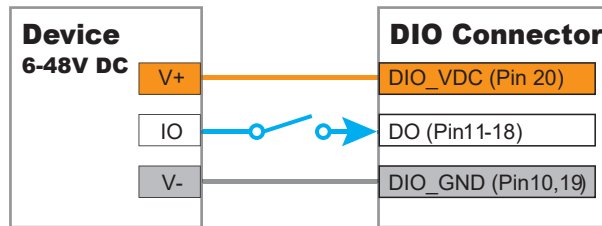

Source Mode
(PNP)

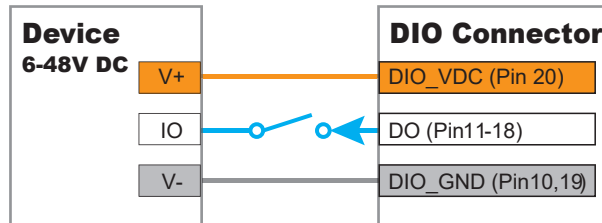

A.3 Software Package Contain

Distribution folder include x32 and x64 versions, use batch file for installation.

There are included as follows :

Win7_32.bat :

Installation for 32-bit driver

Win7_64.bat :

Windows update package which driver required
(need to restart), and Installation for 64-bit driver

Win8_32.bat, Win8_64.bat :

Installation for driver, and
guideline to Framework 3.5 distribution for sample

Win10_32.bat, and Win10_64.bat :

Installation for driver, and
installation to Framework 3.5 distribution for sample

Uninstall_32.bat, and Uninstall_64.bat :

Uninstallation for driver

Run batch file as Administrator.

Support Windows 7 above.

Make sure Windows version before installation.

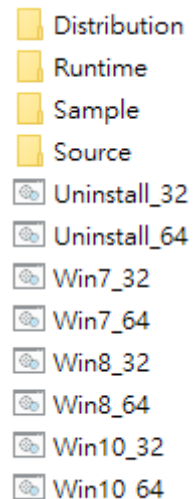

Runtime folder include head file for software developer or System Integration.

Sample folder include sample program, driver library, and API library.

Source folder include sample program source code that compile on Visual Studio 2008.

A.4 Sample

Execute DIO demo tool (ECX1K.exe).



Sample ECX1K.exe, as shown below :

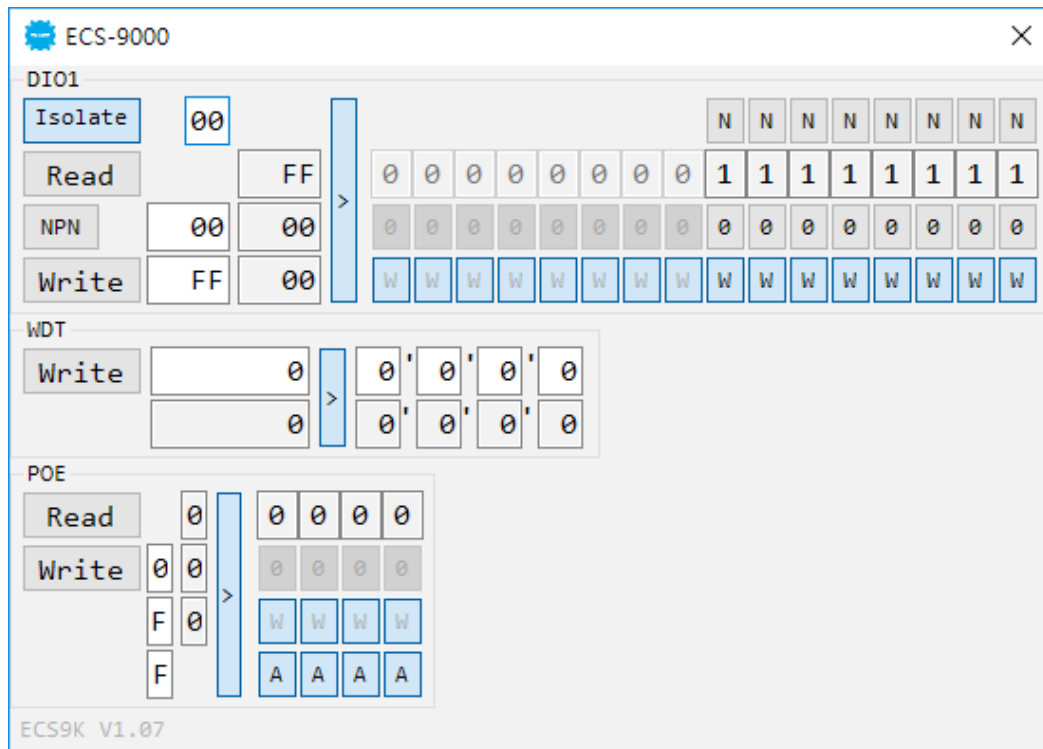

DIO1 Group :

Isolate check button :

DIO type of DIO configuration, isolated/non-isolated, defined in Echo 246F series user manual.

Read button :

Set DIO configuration to get DI/DIO input state.

DO type check button :

User setting, DO type of DIO configuration to setup 8 pins - Source/Sink.

Use for Write (DO) button activate.

Write button :

Set DIO configuration to set DO/DIO output state.

DI preference text :

User setting, DI type of DIO configuration by hexadecimal bitmask - Source/Sink.

Use for Read (DI) button activate.

DO/DIO output text :

User setting, DO/DIO output state by hexadecimal bitmask - on/off.

Use for Write button activate.

DO/DIO writable text :

User setting, DO/DIO writable of DIO configuration by hexadecimal bitmask - yes/no.

Use for Read (DIO)/Write button activate.

DI/DIO input text (read only) :

DI/DIO input state by hexadecimal bitmask - on/off.

Use for Read button activate.

DO/DIO text (read only) :

DO/DIO output state with input state (DIO) and configuration.

Use for Write button activate.

DO/DIO output text (read only) :

DO/DIO output state with configuration.

Use for Write button activate.

DI type pin check button (pin 8 ~ pin 1) :

User setting, DI pin type of DIO configuration - Source/Sink.

DI/DIO input pin texts (read only, pin 8 ~ pin 1/pin 18 ~ pin 11, pin 8 ~ pin 1):

DI/DIO input pin state

Use for Read button activate.

DO/DIO output pin check button (pin 18 ~ pin 11/pin 18 ~ pin 11, pin 8 ~ pin 1):

User setting, DO/DIO output pin state

Use for Write button activate.

DO/DIO pin writable check button (pin 18 ~ pin 11/pin 18 ~ pin 11, pin 8 ~ pin 1):

User setting, DO/DIO pin writable of DIO configuration.

Use for Read (DIO)/Write button activate.

GPIO Group :

Read button :

Set GPIO configuration to get GPIO state.

Write button :

Set GPIO configuration to set GPIO state.

GPIO output text :

User setting, GPIO output state by hexadecimal bitmask - High/Low.

Use for Write button activate.

GPIO writable text :

User setting, GPIO writable of GPIO configuration by hexadecimal bitmask - yes/no.

Use for Read/Write button activate.

GPIO input text (read only) :

GPIO input state by hexadecimal bitmask - High/Low.

Use for Read button activate.

GPIO text (read only) :

GPIO output state with input state and configuration.

Use for Write button activate.

GPIO output text (read only):
GPIO output state with configuration.
Use for Write button activate.

GPIO input pin texts (read only, pin 18 ~ pin 11, pin 8 ~ pin 1):
GPIO input pin state
Use for Read button activate.

GPIO output pin check button (pin 18 ~ pin 11, pin 8 ~ pin 1):
User setting, GPIO output pin state
Use for Write button activate.

GPIO pin writable check button (pin 18 ~ pin 11, pin 8 ~ pin 1):
User setting, GPIO pin writable of GPIO configuration.
Use for Read/Write button activate.

WDT Group :

Write button :
Set WDT when WDT setup text is valid.

Stop button :
Cancel WDT and counting.
Use after Write button action.

WDT setup text :
User setting, WDT value, unit : second.
Use for Write button activate.

WDT counting text (read only) :
WDT counting by program timer after set WDT.
Shown after Write button action.

WDT setup day format texts (user setting) :
User setting, WDT value, format : day'hour'minute'second.

WDT counting day format text (read only) :
WDT counting, format : day'hour'minute'second.

POE Group :

Read button :
Set POE configuration to get POE state.

Write button :
Set POE configuration to set POE state.

POE output text :
User setting, POE output state by hexadecimal bitmask - on/off.
Use for Write button activate.

POE writable text :
User setting, POE writable of POE configuration by hexadecimal bitmask - yes/no.
Use for Write button activate.

POE mode text :
User setting, POE mode of POE configuration by hexadecimal bitmask - Auto/Manual.
Use for Write button activate.

POE input text (read only):

POE input state by hexadecimal bitmask - on/off.

Use for Read button activate.

POE text (read only):

POE output state with input state and configuration.

Use for Write button activate.

POE output text (read only):

POE output state with configuration.

Use for Write button activate.

POE input port texts (read only, port 4 ~ port 1):

POE input port state

Use for Read button activate.

POE output port check button (port 4 ~ port 1):

User setting, POE output port state

Use for Write button activate.

POE port writable check button (port 4 ~ port 1):

User setting, POE port writable of POE configuration.

Use for Write button activate.

POE port mode check button (port 4 ~ port 1):

User setting, POE port mode of POE configuration.

Use for Write button activate.

B

APPENDIX B : Software Functions

B.1 Driver API Guide

In Runtime folder, on ECX1K.h :

 _DLL_IMPORT_ definition is used on LoadLibrary API for ECX1K.dll.

 ECX1K_EXPORTS definition is used on ECX1K.dll building.

 Otherwise, that is used to compile with ECX1K.lib.

BOOL Initial (BYTE Isolate_Type, BYTE DIO_NPN)

Initial machine for DIO, watchdog timer, and POE

 Isolate_Type : DIO type

 1 : Isolated DIO;

 0 : Non-Isolated DIO

 DIO_NPN : DI/DO type

 1 : PNP (Source) mode for European rule;

 0 : NPN (Sink) mode for Japanese rule

Return :

 TRUE (1) : Success;

 FALSE (0) : Fail (Driver not exists, or initial error (version is too old, or machine not match))

BOOL GetDIO1Config (BYTE *Isolate_Type, BYTE *DI_NPN, BYTE *DO_NPN, WORD *Mask)

Get DIO configuration (by variable)

 Isolate_Type : DIO type

 1 : Isolated DIO;

 0 : Non-Isolated DIO

 DI_NPN ([7 : 0]): DI type, pin setting by hexadecimal bitmask

 1 : PNP (Source) mode for European rule;

 0 : NPN (Sink) mode for Japanese rule

 DO_NPN : DO type

 1 : PNP (Source) mode for European rule;

 0 : NPN (Sink) mode for Japanese rule

 Mask ([15:0]): In/Out, pin setting by hexadecimal bitmask

 1 : Output; 0 : Input

Return :

 TRUE (1): Success;

 FALSE (0): Fail (Initial error, or call by pointer error, or hardware problem)

BOOL SetDIO1Config (BYTE *Isolate_Type, BYTE *DI_NPN, BYTE *DO_NPN, WORD *Mask)

Set DIO configuration

Isolate_Type : DIO type

1 : Isolated DIO;

0 : Non-Isolated DIO

DI_NPN ([7:0]): DI type, pin setting by hexadecimal bitmask

1 : PNP (Source) mode for European rule;

0 : NPN (Sink) mode for Japanese rule

DO_NPN : DO type

1 : PNP (Source) mode for European rule;

0 : NPN (Sink) mode for Japanese rule

Mask ([15:0]): In/Out, pin setting by hexadecimal bitmask

1 : Output;

0 : Input

Return :

TRUE (1): Success;

FALSE (0): Fail (Initial error, or hardware problem)

BOOL GetDI1 (BYTE *DI)

Get isolated DIO input (DI)

DI ([7:0]): Input state, pin setting by hexadecimal bitmask

1 : High;

0 : Low

Return :

TRUE (1): Success;

FALSE (0): Fail (Initial error, or call by pointer error, or hardware problem)

BOOL GetDO1 (BYTE *DO)

Get isolated DIO output (DO)

DO ([7:0]): Output state, pin setting by hexadecimal bitmask

1 : High;

0 : Low

Return :

TRUE (1): Success;

FALSE (0): Fail (Initial error, or call by pointer error, or hardware problem)

BOOL SetDO1 (BYTE DO)

Set isolated DIO output (DO)

DO ([7:0]): Output state, pin setting by hexadecimal bitmask

1 : High;

0 : Low

Return :

TRUE (1): Success;

FALSE (0): Fail (Initial error, or hardware problem)

BOOL GetDIO1 (WORD *DI)

Get non-isolated DIO input (DIO input)

DI ([15:0]): Input state, pin setting by hexadecimal bitmask

1 : High;

0 : Low

Return :

TRUE (1): Success;

FALSE (0): Fail (Initial error, or call by pointer error, or hardware problem)

BOOL SetDIO1 (WORD DO)

Set non-isolated DIO output (DIO output)

DO ([15:0]): output state, pin setting by hexadecimal bitmask

1 : High;

0 : Low

Return :

TRUE (1): Success;

FALSE (0): Fail (Initial error, or hardware problem)

BOOL GetGPIOConfig (WORD *Mask)

Get GPIO configuration (by variable)

Mask ([15:0]): In/Out, pin setting by hexadecimal bitmask

1 : Output;

0 : Input

Return :

TRUE (1): Success;

FALSE (0): Fail (Initial error, or call by pointer error, or hardware problem)

BOOL SetGPIOConfig (WORD Mask)

Set GPIO configuration

Mask ([15:0]): In/Out, pin setting by hexadecimal bitmask

1 : Output;

0 : Input

Return :

TRUE (1): Success;

FALSE (0): Fail (Initial error, or hardware problem)

BOOL GetGPIO (WORD *DI)

Get GPIO input

DI ([15:0]): Input state, pin setting by hexadecimal bitmask

1 : High;

0 : Low

Return :

TRUE (1): Success;

FALSE (0): Fail (Initial error, or call by pointer error, or hardware problem)

BOOL SetGPIO (WORD DO)

Set GPIO output

DO ([15:0]): output state, pin setting by hexadecimal bitmask

1 : High;

0 : Low

Return :

TRUE (1): Success;

FALSE (0): Fail (Initial error, or hardware problem)

BOOL GetWDT (DWORD *WDT)

Get watchdog timer setup

WDT : watchdog timer setup

Unit : second. (Range : 0 ~ 65535 sec, 1093 ~ 65535 min (=65580 ~ 3932100 sec))

Return :

TRUE (1): Success;

FALSE (0): Fail (Initial error, or call by pointer error, or hardware problem)

BOOL SetWDT (DWORD WDT)

Set watchdog timer setup

WDT : watchdog timer setup

Unit : second. (Range : 1 ~ 65535 sec, 1093 ~ 65535 min (=65580 ~ 3932100 sec))

Return :

TRUE (1) : Success;

FALSE (0) : Fail (Initial error, or setup 0 error, or hardware problem)

BOOL CancelWDT ()

Cancel watchdog timer

Return :

TRUE (1) : Success;

FALSE (0) : Fail (Initial error, or hardware problem)

BOOL GetPOEConfig (BYTE *Auto, BYTE *Mask)

Get POE configuration (by variable)

Auto ([3:0]): Auto mode, pin setting by hexadecimal bitmask

1 : Auto;

0 : Manual

Mask ([3:0]): DC Enable/Disable, pin setting by hexadecimal bitmask

1 : Enable;

0 : Disable

Return :

TRUE (1): Success;

FALSE (0): Fail (Initial error, or call by pointer error, or hardware problem)

BOOL SetPOEConfig (BYTE Auto, BYTE Mask)

Set POE configuration

Auto ([3:0]): Auto mode, pin setting by hexadecimal bitmask

1 : Auto;

0 : Manual

Mask ([3:0]): DC Enable/Disable, pin setting by hexadecimal bitmask

1 : Enable;

0 : Disable

Return :

TRUE (1): Success;

FALSE (0): Fail (Initial error, or out of range error, or hardware problem)

BOOL GetPOE (BYTE *POE)

Get POE input

POE ([3:0]): POE state, pin setting by hexadecimal bitmask

1 : On;

0 : Off

Return :

TRUE (1): Success;

FALSE (0): Fail (Initial error, or call by pointer error, or hardware problem)

BOOL SetPOE (BYTE POE)

Set POE output

POE ([3:0]): POE state, pin setting by hexadecimal bitmask

1 : On;

0 : Off

Return :

TRUE (1): Success;

FALSE (0): Fail (Initial error, or out of range error, or hardware problem)



APPENDIX C : Power Consumption

Testing Board	Echo 246F
RAM	16GB * 2
USB-1	USB Microsoft Wired Keyboard 600
USB-2	USB Mouse HP G1K28AA
USB-3	USB Flash Transecnd 3.0 8GB
USB-4	USB Flash Transecnd 3.0 8GB
USB-5	USB Flash Kingston 3.0 16GB
USB-6	USB Flash Kingston 3.0 32GB
CFAST	Transcend CFX600 CFast 128GB
SATA 0	Transcend SATA SSD420 128GB
SATA 1	Seagate HDD 500GB
LAN 1 (i219)	1.0 Gbps
LAN 2 (i210)	1.0 Gbps
LAN 3 (i210)	1.0 Gbps
LAN 4 (i210)	1.0 Gbps
Graphics Output	DVI
Power Plan	Balance (Windows10 Power plan)
Power Source	Chroma 62006P-100-25
Test Program-1	BurnInTest

C.1 Intel® Core™ i7-8700T (8M Cache, 2.40GHz)

Power on and boot to Win 10 (64-bit)

CPU	Power Input	Power on and boot to Win 10 (64-bit)					
		Standby Mode		Sleep Mode		idle status CPU usage less 3%	
		Max Current	Max Consumption	Max Current	Max Consumption	Max Current	Max Consumption
Core™ i7-8700T	9V	0.348A	03.13W	0.505A	04.54W	2.589A	23.30W
Core™ i7-8700T	12V	0.274A	03.28W	0.394A	04.73W	1.796A	21.55W
Core™ i7-8700T	24V	0.181A	04.35W	0.245A	05.88W	0.837A	20.10W
Core™ i7-8700T	36V	0.160A	05.74W	0.180A	06.48W	0.769A	27.69W

CPU	Power Input	Power on and boot to Win10 (64-bit)			
		Run 100% CPU usage with 2D		Run 100% CPU usage with 3D	
		Max Current	Max Consumption	Max Current	Max Consumption
Core™ i7-8700T	9V	4.943A	44.49W	6.101A	54.91W
Core™ i7-8700T	12V	3.700A	44.40W	4.980A	59.76W
Core™ i7-8700T	24V	1.829A	43.90W	2.329A	55.89W
Core™ i7-8700T	36V	1.364A	49.09W	1.642A	59.13W

C.2 Intel® Core™ i7-8700 (12M Cache, 3.20GHz)

Power on and boot to Win 10 (64-bit)

CPU	Power Input	Power on and boot to Win 10 (64-bit)					
		Standby Mode		Sleep Mode		idle status CPU usage less 3%	
		Max Current	Max Consumption	Max Current	Max Consumption	Max Current	Max Consumption
Core™ i7-8700	9V	0.348A	03.13W	0.505A	04.54W	2.949A	26.54W
Core™ i7-8700	12V	0.274A	03.28W	0.394A	04.73W	2.502A	30.02W
Core™ i7-8700	24V	0.181A	04.35W	0.245A	05.88W	1.174A	28.18W
Core™ i7-8700	36V	0.160A	05.74W	0.180A	06.48W	0.573A	20.63W

CPU	Power Input	Power on and boot to Win10 (64-bit)			
		Run 100% CPU usage with 2D		Run 100% CPU usage with 3D	
		Max Current	Max Consumption	Max Current	Max Consumption
Core™ i7-8700	9V	4.943A	44.49W	8.668A	78.01W
Core™ i7-8700	12V	3.700A	44.40W	6.587A	79.05W
Core™ i7-8700	24V	1.829A	43.90W	3.064A	73.53W
Core™ i7-8700	36V	1.364A	49.09W	2.034A	73.23W

C.3 Intel® Xeon® E-2176G (12M Cache, up to 4.70GHz)

Power on and boot to Win 10 (64-bit)

CPU	Power Input	Power on and boot to Win 10 (64-bit)					
		Standby Mode		Sleep Mode		idle status CPU usage less 3%	
		Max Current	Max Consumption	Max Current	Max Consumption	Max Current	Max Consumption
Xeon® E-2176G	9V	0.363A	03.27W	0.524A	04.72W	2.250A	20.25W
Xeon® E-2176G	12V	0.284A	03.41W	0.400A	04.80W	1.847A	22.16W
Xeon® E-2176G	24V	0.185A	04.44W	0.251A	06.02W	1.227A	29.45W
Xeon® E-2176G	36V	0.166A	05.96W	0.202A	07.25W	0.785A	28.25W

CPU	Power Input	Power on and boot to Win10 (64-bit)			
		Run 100% CPU usage with 2D		Run 100% CPU usage with 3D	
		Max Current	Max Consumption	Max Current	Max Consumption
Xeon® E-2176G	9V	9.544A	85.90W	10.447A	94.02W
Xeon® E-2176G	12V	6.820A	81.84W	7.982A	95.78W
Xeon® E-2176G	24V	3.422A	82.12W	4.141A	99.38W
Xeon® E-2176G	36V	2.324A	83.67W	2.839A	102.21W

D

APPENDIX D : RAID Functions

D.1.1 SATA Mode for RAID

Please select SATA Device to RAID mode on BIOS menu.

Advanced → SATA Configuration → SATA Mode Selection → RAID/Intel RST Premium

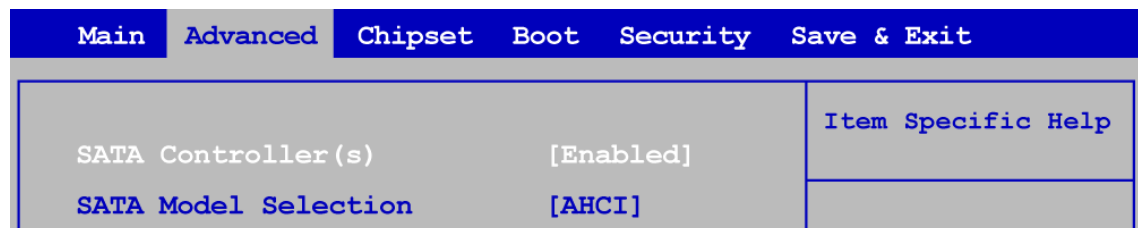

D.1.2 UEFI Mode for RAID

1. Please select SATA device to RAID mode on BIOS menu.

Advanced → SATA Configuration → SATA Mode Selection → RAID/Intel RST Premium

2. Please select Software Feature Mask Configuration on BIOS menu.

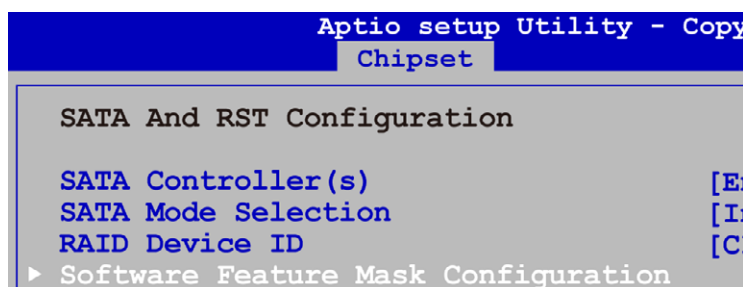

3. Use RST Legacy OROM → Disabled → Save Changes and Reset.

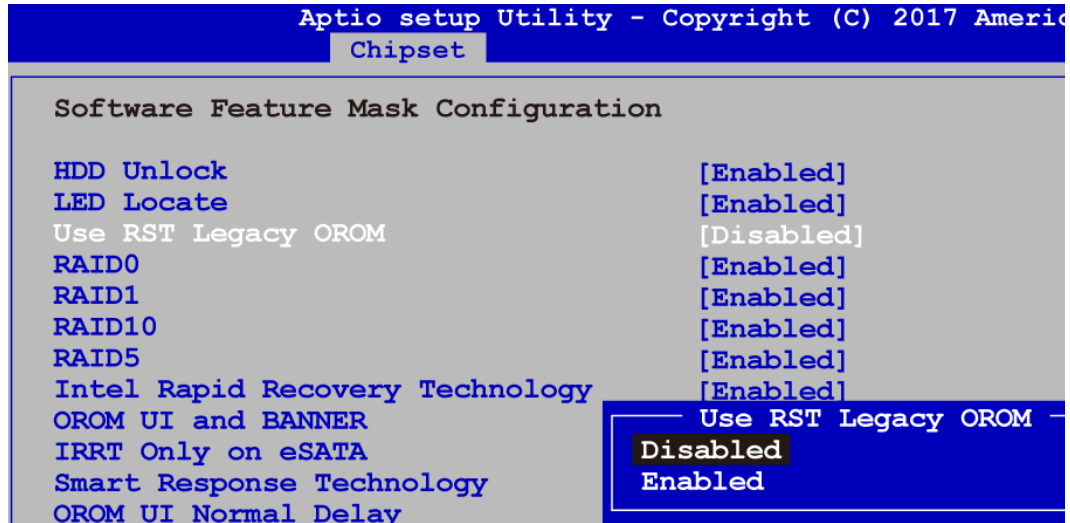

4. Into BIOS menu again, select Intel(R) Rapid Storage Technology on BIOS menu.

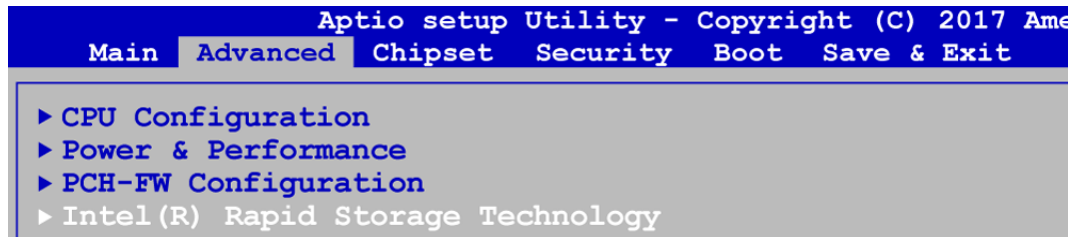

5. Select Create RAID Volume on BIOS menu.

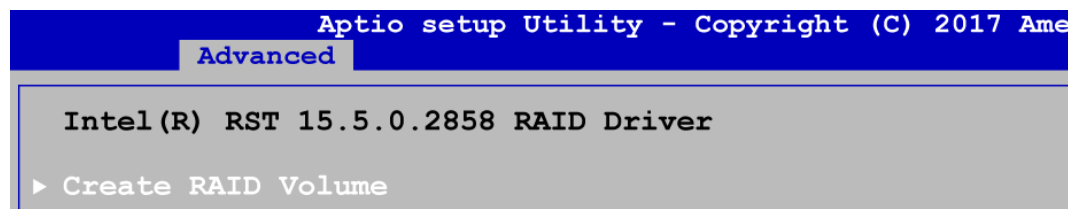

6. Select disks to create RAID Volume then Save Changes and Reset to install OS with EFI mode.

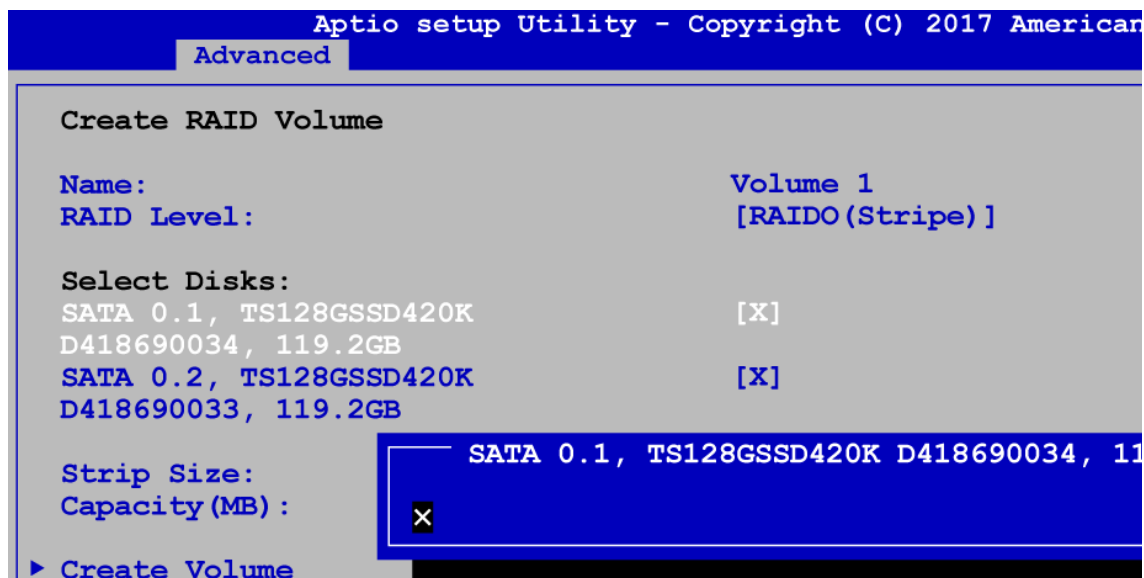

D.2 OS Installation

The system is featured with two SATA, including two internal SATA. We used SATA for Windows 10 OS installation as an example.

D.3 To Install All Device Drivers of the System

The instructions are as follows :

1. Install Chipset driver
2. Install Network driver
3. Install ME driver (if available)
4. Install Audio driver
5. Install VGA driver

D.4 To Install "Intel Rapid Storage Technology" Software

You can get the software from driver CD.

Also, you can find the latest information and software directly from Intel's website.

http://www.intel.com/p/en_US/support/highlights/chpsts/ismm

The RAID environment has been done if you completed the steps above.

D.5 To Insert SATA HDD for RAID 1

Please note, you can use two SATA ports for SATA HDD, except for mSATA slot.

D.6 To Create RAID Volume on "Rapid Storage Technology" Software

The system is featured with two SATA HDD's for RAID volume, so there are two options to choose on this page. Let's take RAID 1 as an example, select "RAID 1".



D.7 Disk Management : Partition the Disk

After RAID 1 volume is created, you can see the figure of SATA device allocation.

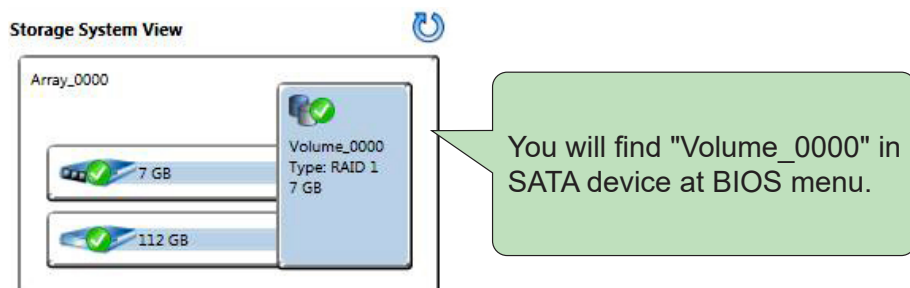

To start disk management tool, select "initialize disk".

Then add "Logical Device" for Windows access.

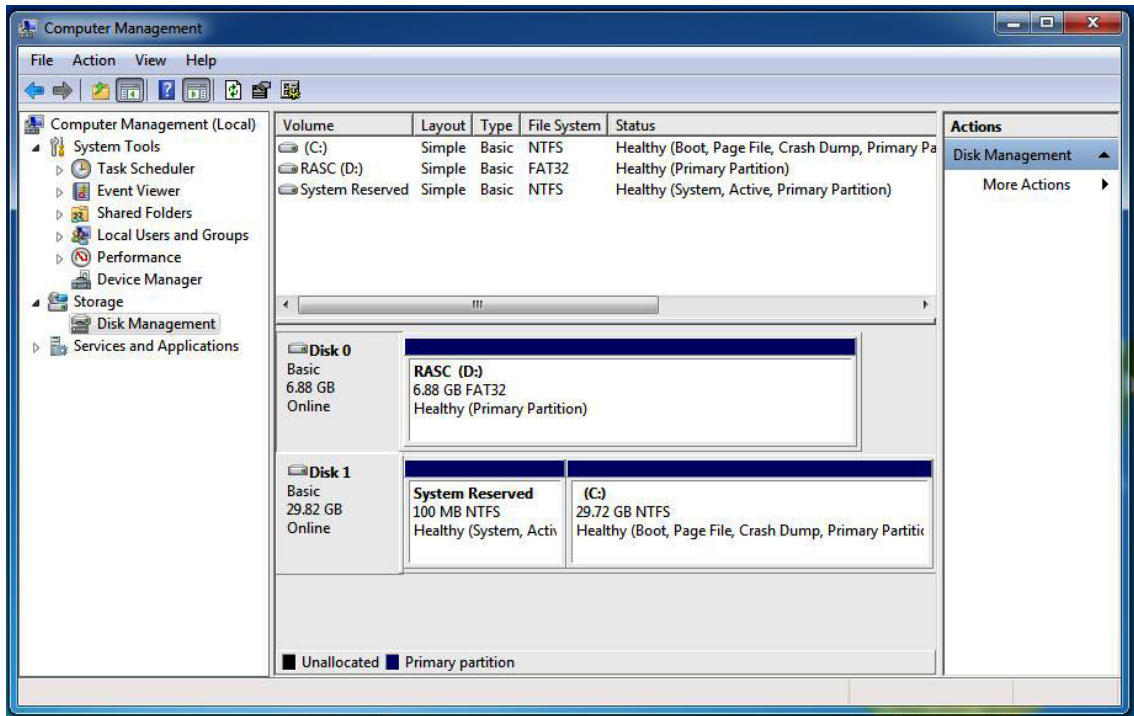

D.8 If One SATA HDD on RAID Volume is Out-of-use

After RAID 1 volume is created, you can see the figure of SATA device allocation.

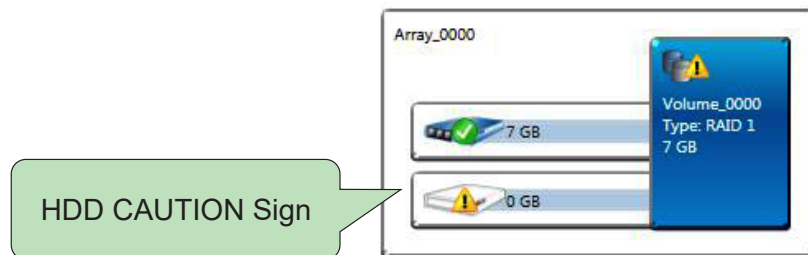

D.9 Recovery and Auto Rebuild When Use the **SAME** RAID HDD

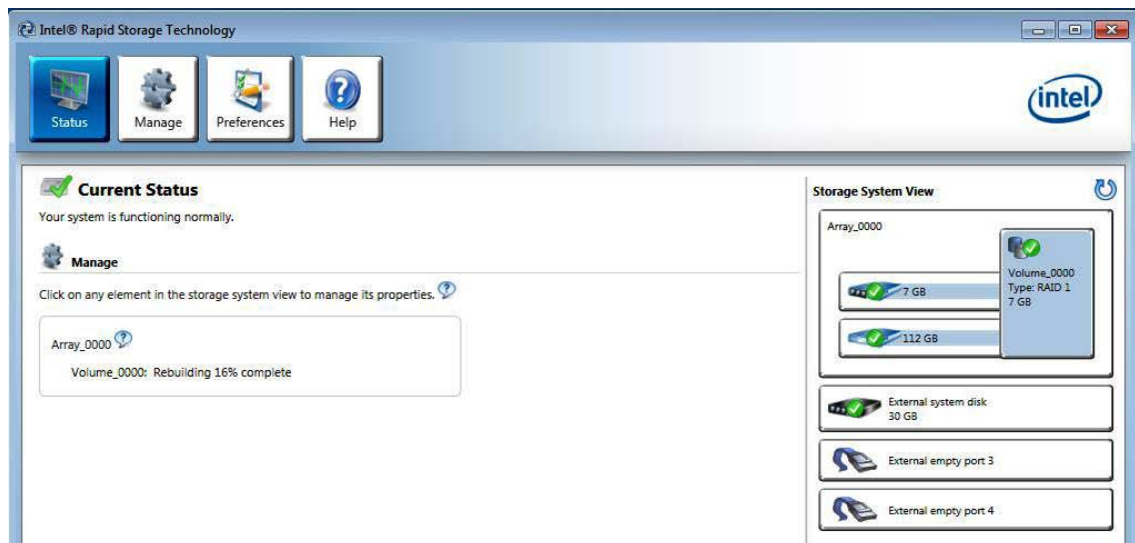

C.10 Recovery and Auto Rebuild When Use **DIFFERENT** RAID HDD

A warning will pop-up to ask you if the disk is not a member of the original RAID volume.

If you press "Rebuild", it will replace the broken SATA HDD to the last SATA HDD of RAID volume.

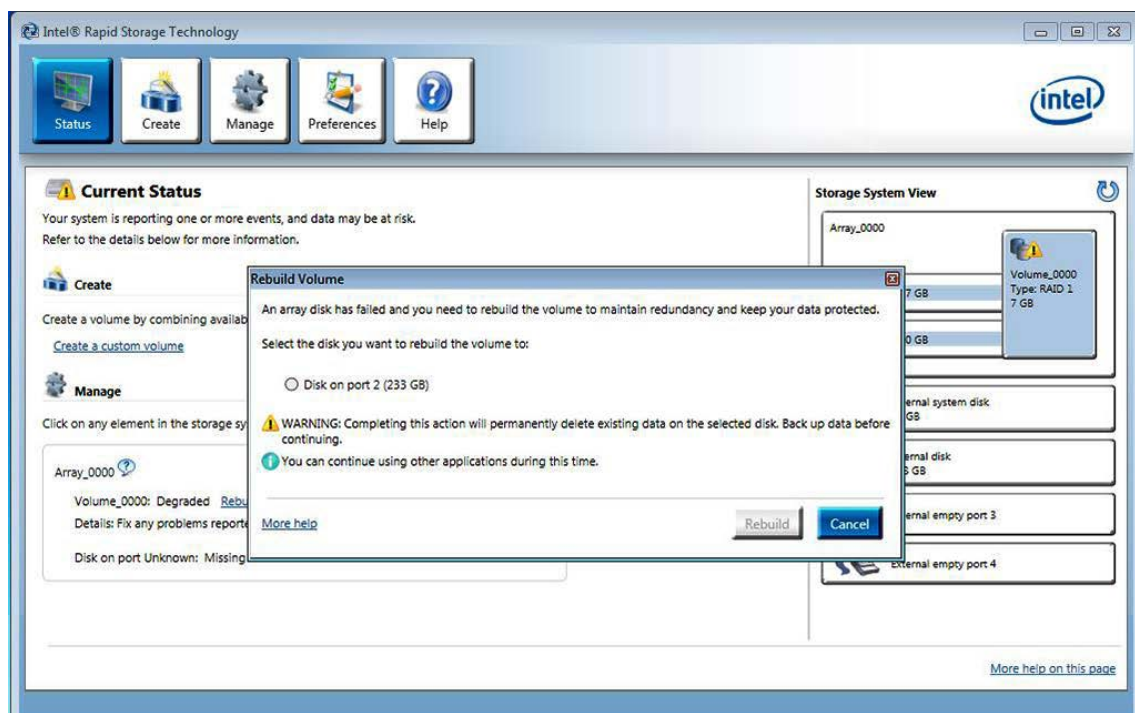

E

APPENDIX E : Supported Memory & Storage List

E.1 Test Item

Testing Board	Echo 246F
Memory Test	version : 5.1
BurnInTest	V 8.1

Channel	Memtest	Bunin	Flash BIOS	Remove Battery
*2	PASS	PASS	PASS	PASS
*1 (Socket 1)	PASS	PASS	N/A	PASS
*1 (Socket 2)	PASS	PASS	N/A	PASS

E.2 Supported Non-ECC Memory List

Brand	Info	Test Temp. (Celsius)
Transcend 16GB 2RX8 DDR4 2133 SO	TS0CASGSB0000	25°C
		25°C
Kingston 8GB 1Rx8 1G x 64-Bit PC4-2133 CL15 260-Pin SODIMM	KVR21S15S8/8	25°C
		25°C
Kingston 16GB 2Rx8 2G x 64-Bit PC4-2133 CL15 260-Pin SODIMM	KVR21S15D8/16	25°C
		25°C
Innodisk 16G DDR4 2400 SODIMM	M4S0-AGS1OCSJ-H03	25°C
		25°C
Innodisk 16G DDR4 2400 SODIMM	M4S0-4GSSN5SJ-H03	25°C
		25°C
MEMXPRO 8G DDR4 2666-19 SODIMM	D4D8GHLQHJI-AH	25°C
		25°C
MEMXPRO 16G DDR4 2666-19 SODIMM	D4SAGHLQHFI-AH	25°C
		25°C
MEMXPRO 8G DDR4 2666-19 SODIMM	D4S8GHLQHEC-AH	25°C
		25°C
MEMXPRO 16G DDR4 2666-19 SODIMM	D4SAGHLQHFC-AH	25°C
		25°C
MEMXPRO 8G DDR4 2666-19 SODIMM	D4S8GHLQHEI-AH	25°C
		25°C

Brand	Info	Test Temp. (Celsius)
MEMXPRO 8G DDR4 2666-19 SODIMM	D4D8GHLQHJC-AH	25°C
		25°C
Innodisk 16G DDR4 2666 W/T SODIMM	M4S0-AGS1O5IK-H03	25°C
		25°C
Innodisk 8G DDR4 2666 W/T SODIMM	M4S0-8GS1N5IK-H03	25°C
		25°C
Innodisk 4G DDR4 2666 W/T SODIMM	M4S0-4GSSN5IK-H03	25°C
		25°C
Kingston 4GB PC4-2666 CL19 SODIMM	KVR26S19S6/4	25°C
		25°C
Kingston 8GB PC4-2666 CL19 SODIMM	KVR26S19S8/8	25°C
		25°C
Kingston 16GB PC4-2666 CL19 SODIMM	KVR26S19D8/16	25°C
		25°C

E.3 Supported ECC Memory List

Brand	Info	Test Temp. (Celsius)
Kingston 8GB 2RX8 PC4-2133P-TG1-11 SODIMM	KVR21SE15D8/8	25°C
		25°C
Kingston 4GB 1RX8 PC4-2133P-TD1-11 SODIMM	KVR21SE15S8/4	25°C
		25°C
Innodisk 4G DDR4 2400 SODIMM	M4D0-4GSSPCSJ-H03	25°C
		25°C
Innodisk 16G DDR4 2400 W/T SODIMM	M4D0-AGS1Q5SJ-H03	25°C
		25°C
MEMXPRO 16G DDR4 2466-19 SODIMM	D4DAGHLQHKC-AH	25°C
		25°C
MEMXPRO 16G DDR4 2466-19 SODIMM	D4DAGHLQHKI-AH	25°C
		25°C
SLINK (MBG-JBM) 16G DDR4 2666 SODIMM	J4AGDH1G8QHKC	25°C
		25°C
Innodisk 16G DDR4 2666 W/T SODIMM	M4S0-AGS1Q5IK-H03	25°C
		25°C
Innodisk 8G DDR4 2666 W/T SODIMM	M4S0-8GS1P5IK-H03	25°C
		25°C
Innodisk 4G DDR4 2666 W/T SODIMM	M4S0-4GSSP5IK-H03	25°C
		25°C
Innodisk 16G DDR4 2666 W/T SODIMM	M4S0-AGS1QCIC-H03	25°C
		25°C
Innodisk 4G DDR4 2666 W/T SODIMM	M4S0-4GSSPCIK-H03	25°C
		25°C
SL-LINK 32GB DDR4 2666 SODIMM	J4BGSS2G8QHXC	25°C
		25°C

E.4 Supported Storage Device List

Type	Brand	Model	Capacity
mSATA	Transcend	mSATA TS64GMSA370	64GB
	Intel	Intel-310 SSDMAEMC080G2	80GB
	Innodisk	DEMSR-32GD06SW2QC	32GB
SSD	Intel	SSD E 5400s SSDSC2KR120H6	120GB
	Innodisk	3MG2-P DGS25-64GD81BC1QC	64GB
	LITE-ON	K8-L1512	512GB
		K8-L1256	256GB
	Transcend	TS128GSSD420K	128GB
	Kingston	SUV400S37	120GB
SATA HDD	Seagate	SDC001	500GB
CFast	Transcend	TS128GCFX600	120GB
	Innodisk	3ME4 DECFA-A28M41BC1DC-H03	128GB
M.2 Key M	Toshiba	KXG50ZNV512G	512GB

** If more help is needed, please contact Technical Support.**

For further support information, please visit www.CappuccinoPC.com

This document is released for reference purpose only.

All product offerings and specifications are subject to change without prior notice.

No part of this publication may be reproduced in any form or by any means, electric, photocopying, or recording, without prior authorization from the publisher.

The rights of all the brand names, product names, and trademarks belong to their respective owners.

© CappuccinoPC. 2018. All rights reserved.